

RICK BRAUTIGAN ARCHITECTURE

10255 DIXIE HIGHWAY  
DAIRY BEACH, FL 33483  
PH: 561.272.9086  
FX: 561.272.5636  
A/C: 002029

PRELIMINARY SET: 06/07/15

NOTE:  
ALL SPECIALTY ITEMS TO BE SUPPLIED BY THE CONTRACTOR AND SHALL BE INSTALLED AND OPERATED IN ACCORDANCE WITH THE MANUFACTURER'S INSTRUCTIONS. THE CONTRACTOR SHALL BE RESPONSIBLE FOR OBTAINING ALL NECESSARY PERMITS AND APPROVALS. THE CONTRACTOR SHALL BE RESPONSIBLE FOR OBTAINING ALL NECESSARY PERMITS AND APPROVALS. THE CONTRACTOR SHALL BE RESPONSIBLE FOR OBTAINING ALL NECESSARY PERMITS AND APPROVALS.

FORUMICA ASSOCIATES  
Consulting Engineers  
3500 N.W. Boca Raton Blvd.  
Boca Raton, FL 33481  
TEL: (561) 993-8000  
FAX: (561) 993-8001  
www.forumica.com

Kelly Building for:  
**Schmidt Investment Properties, LLC**  
1302 Wallace Drive  
Dairy Beach, FL 33444  
RBA, PN, 1371409

REVISIONS

DETAILS AND RISERS

N.T.S.

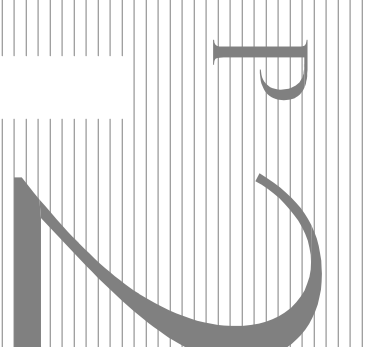

ALL SPECIALTY ITEMS TO BE SUPPLIED BY THE CONTRACTOR AND SHALL BE INSTALLED AND OPERATED IN ACCORDANCE WITH THE MANUFACTURER'S INSTRUCTIONS. THE CONTRACTOR SHALL BE RESPONSIBLE FOR OBTAINING ALL NECESSARY PERMITS AND APPROVALS. THE CONTRACTOR SHALL BE RESPONSIBLE FOR OBTAINING ALL NECESSARY PERMITS AND APPROVALS. THE CONTRACTOR SHALL BE RESPONSIBLE FOR OBTAINING ALL NECESSARY PERMITS AND APPROVALS.

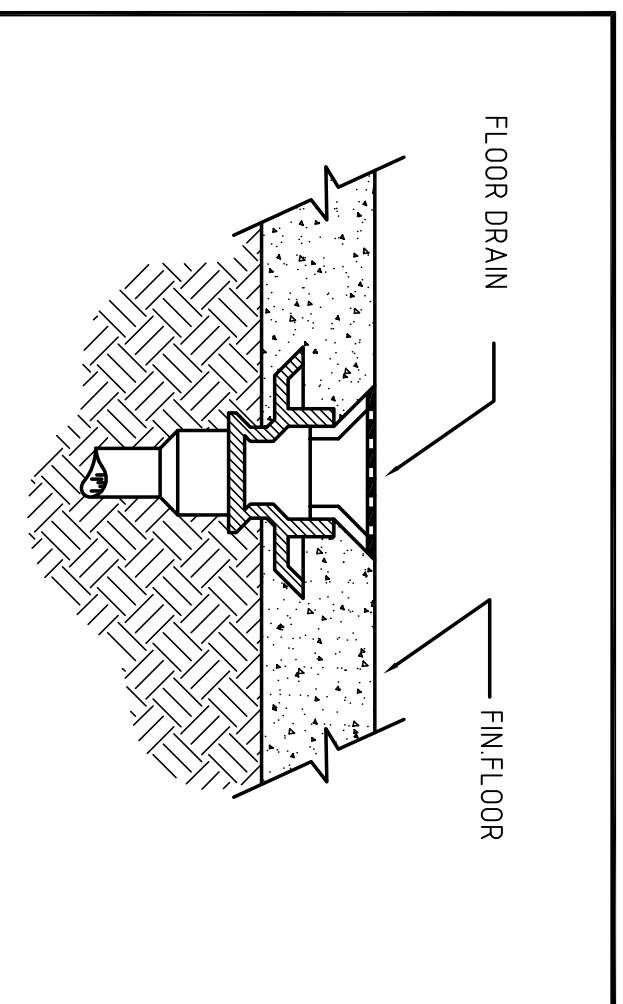

DETAIL NO. 1 FLOOR DRAIN DETAIL NOT TO SCALE

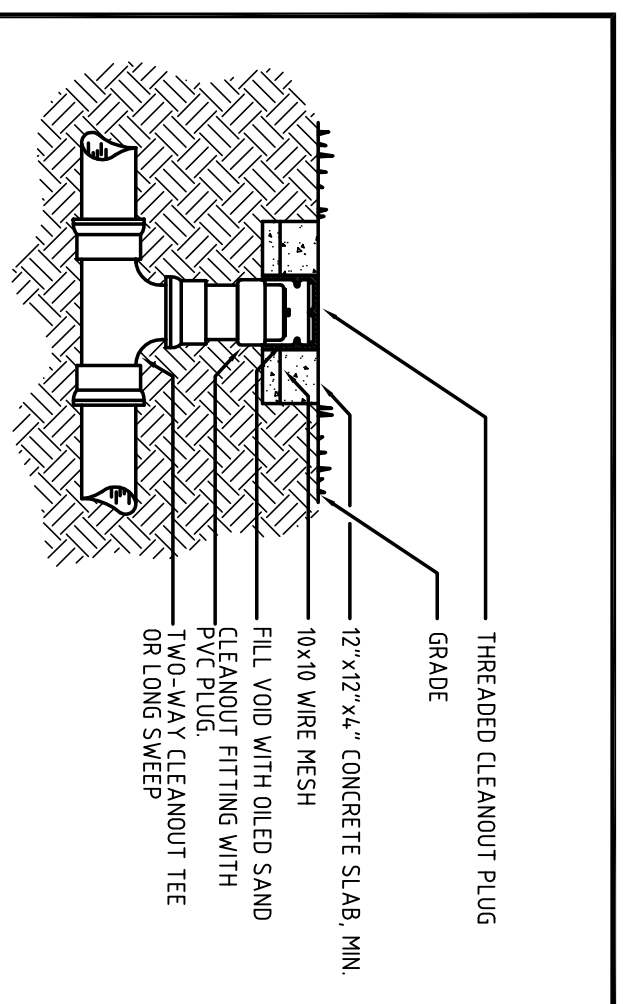

DETAIL NO. 2 CLEAN-OUT TO GRADE NOT TO SCALE

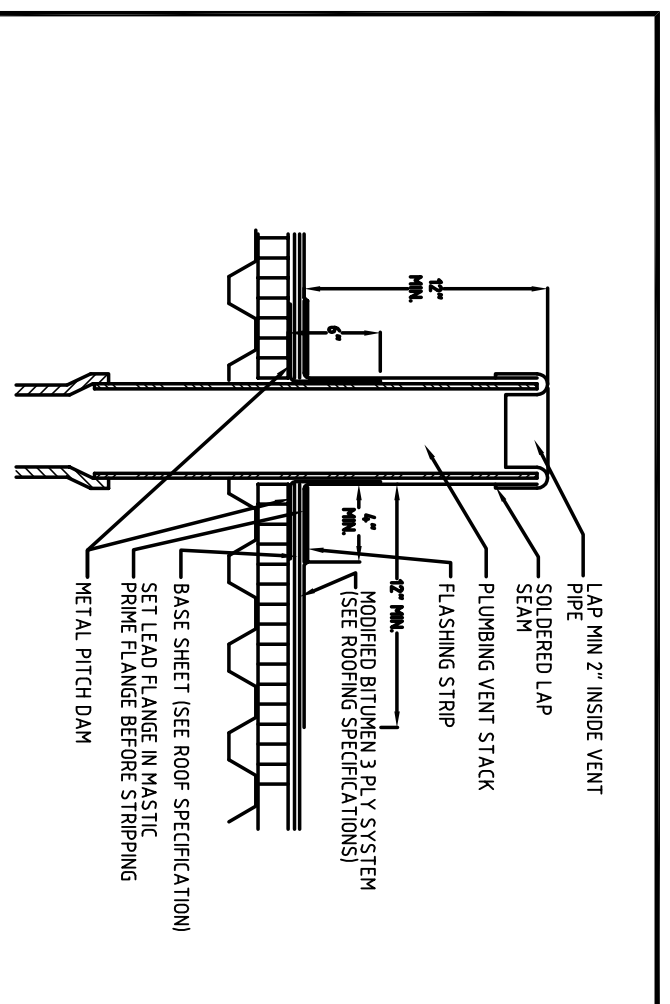

DETAIL NO. 3 VENT THROUGH ROOF NOT TO SCALE

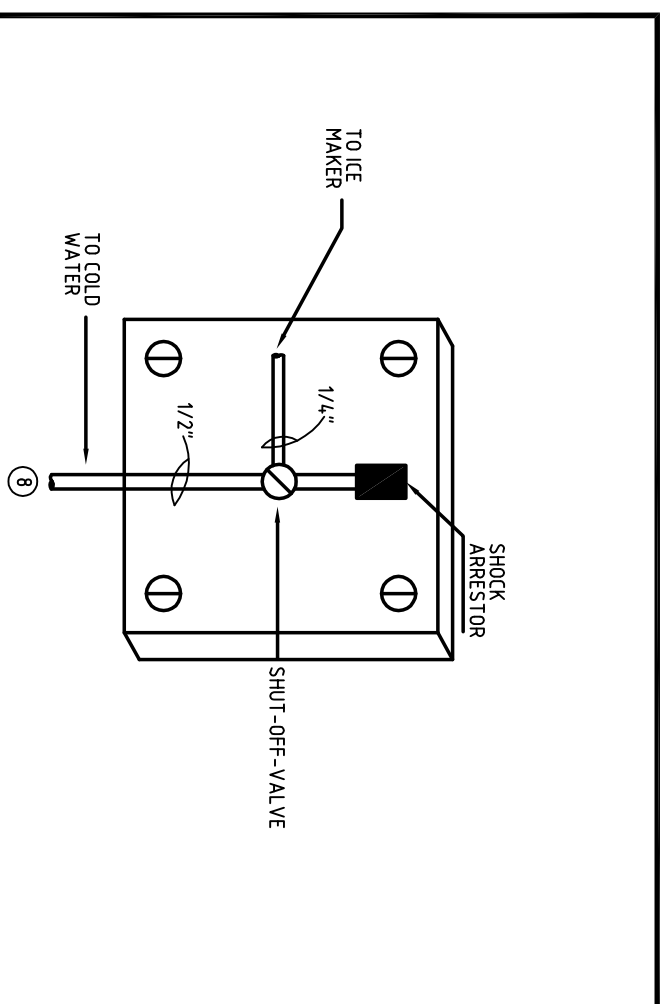

DETAIL NO. 4 ICE MAKER BOX DETAIL NOT TO SCALE

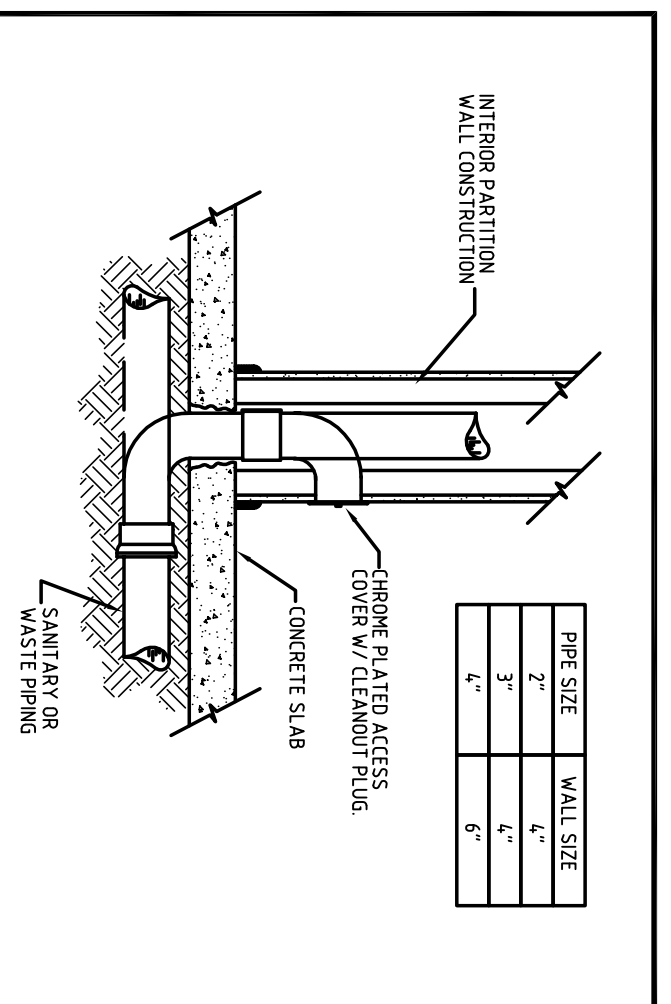

DETAIL NO. 5 WALL CLEAN-OUT NOT TO SCALE

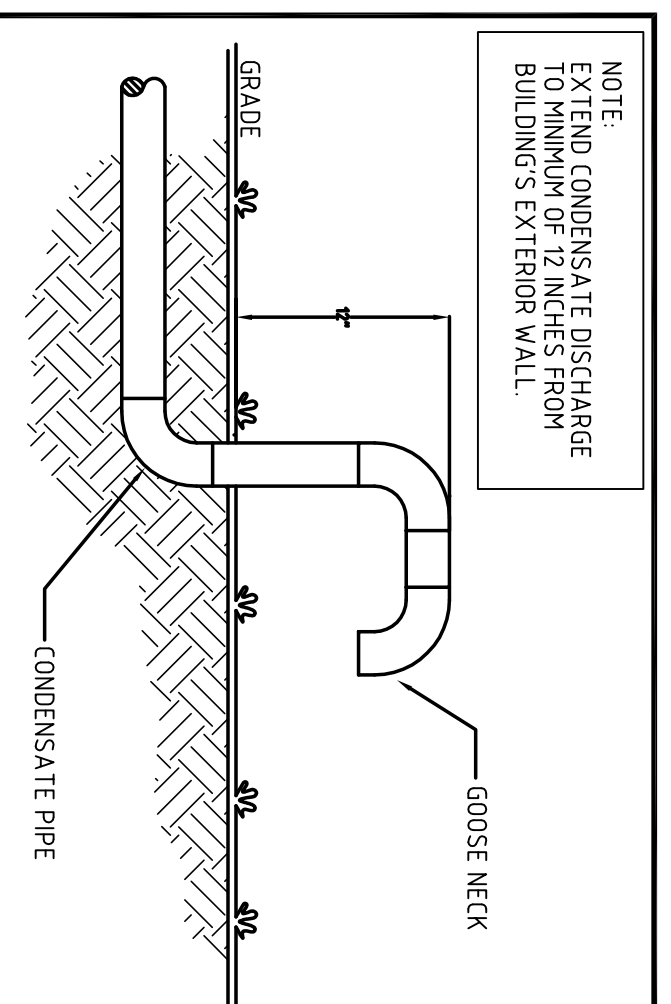

DETAIL NO. 6 CONDENSATE DISCHARGE NOT TO SCALE

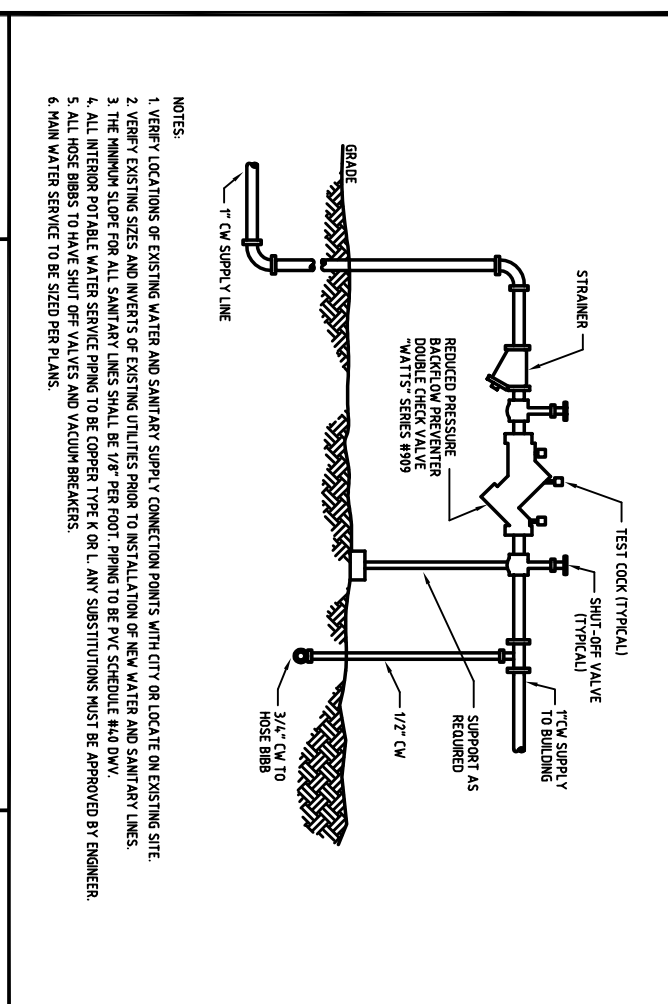

DETAIL NO. 7 BACKFLOW PREVENTOR ASSEMBLY NOT TO SCALE

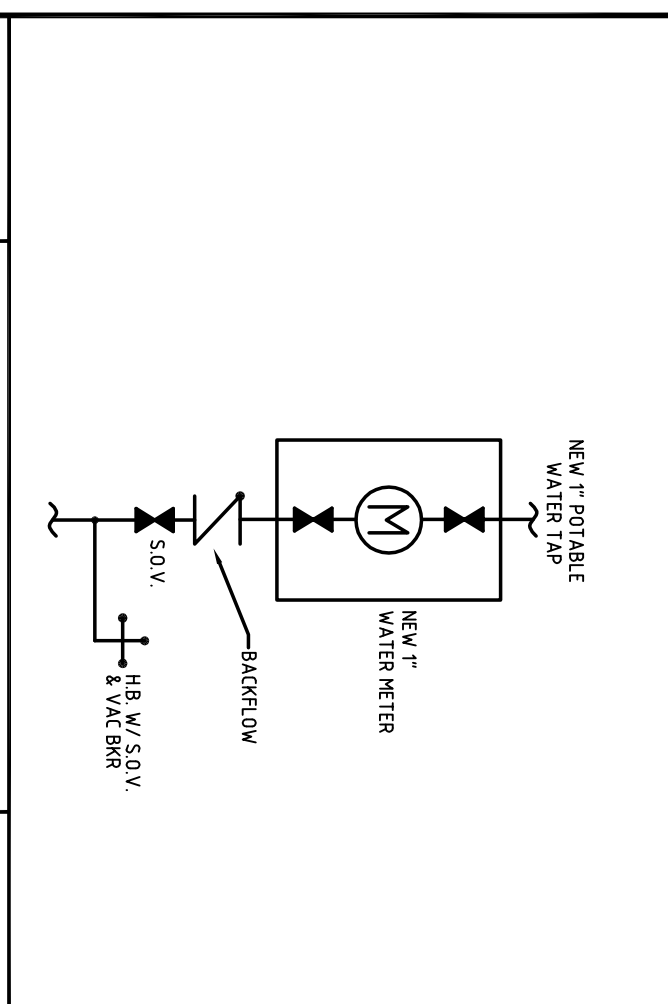

DETAIL NO. 8 WATER SERVICE CONNECTION NOT TO SCALE

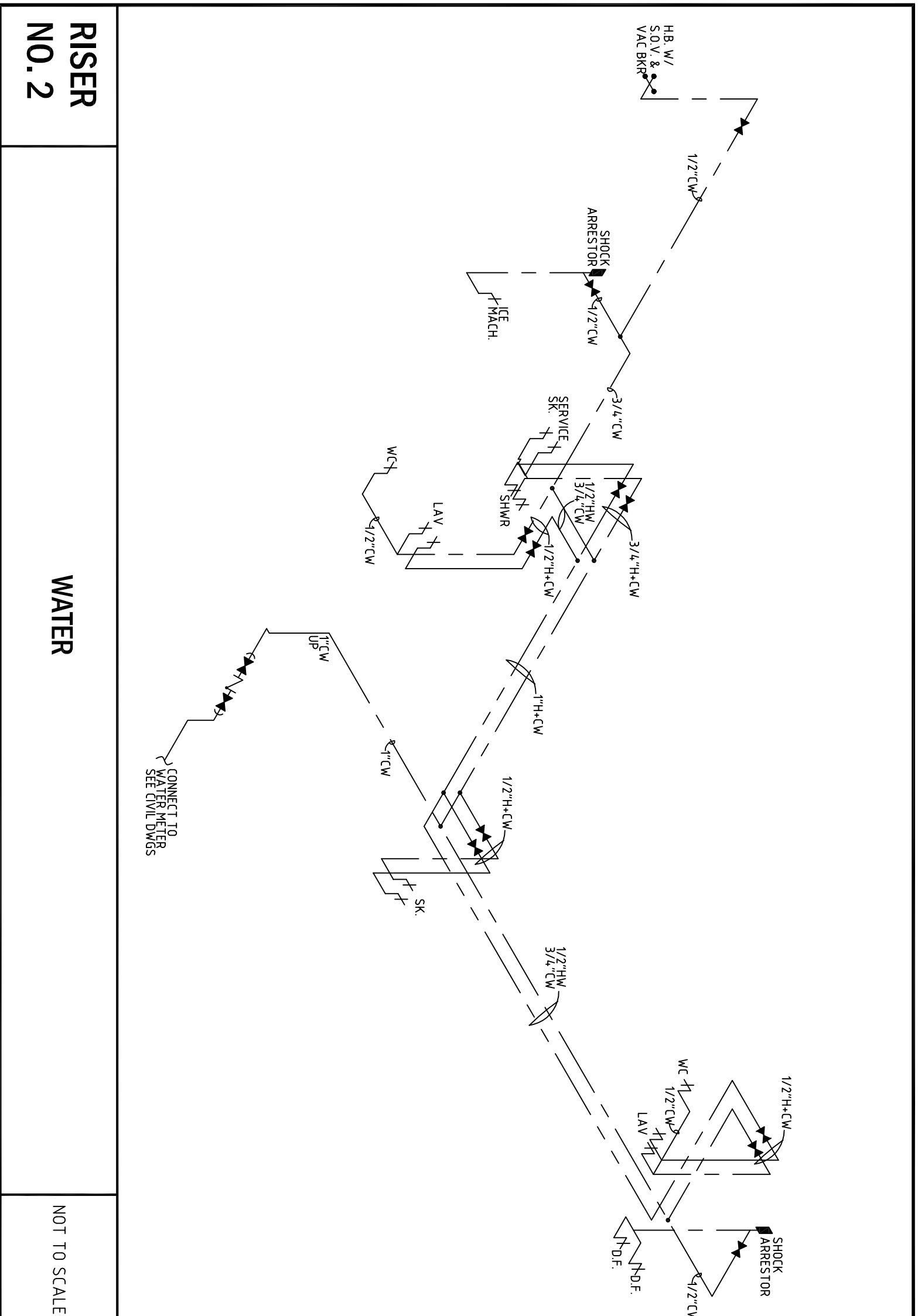

DETAILS AND RISERS  
N.T.S.