

DETAIL NO. 1 VENT THROUGH ROOF NOT TO SCALE

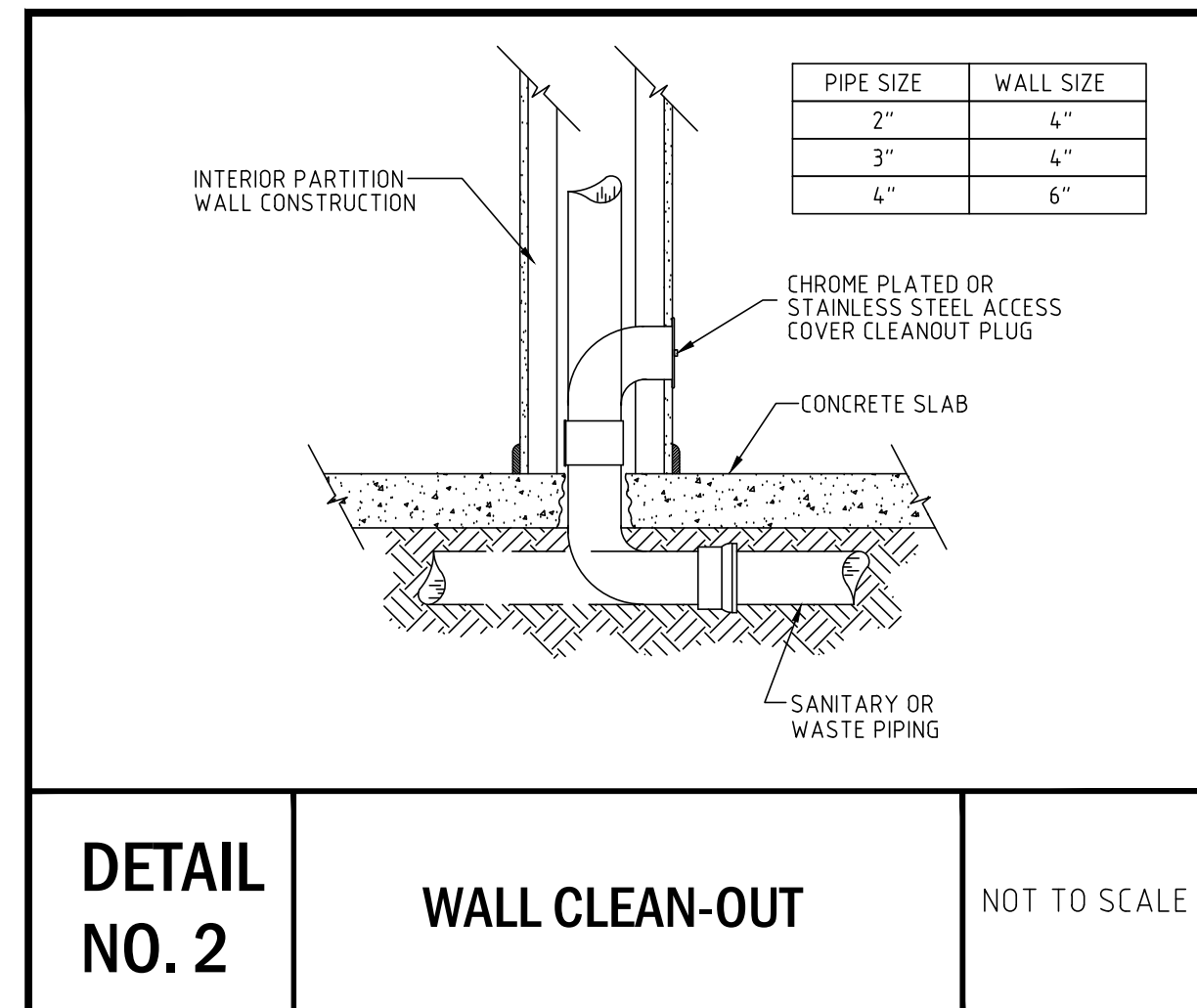

DETAIL NO. 2 WALL CLEAN-OUT NOT TO SCALE

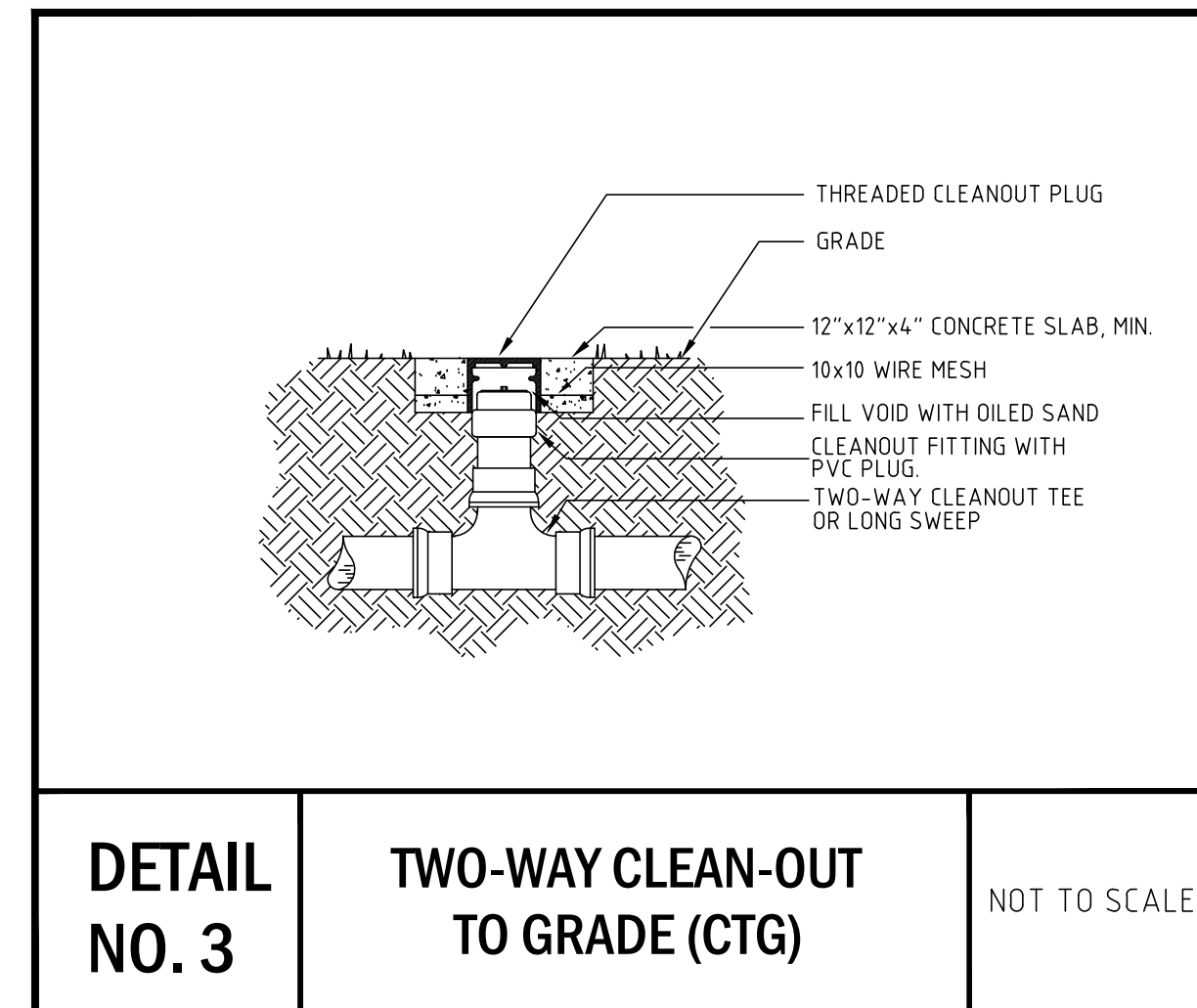

DETAIL NO. 3 TWO-WAY CLEAN-OUT TO GRADE (CTG) NOT TO SCALE

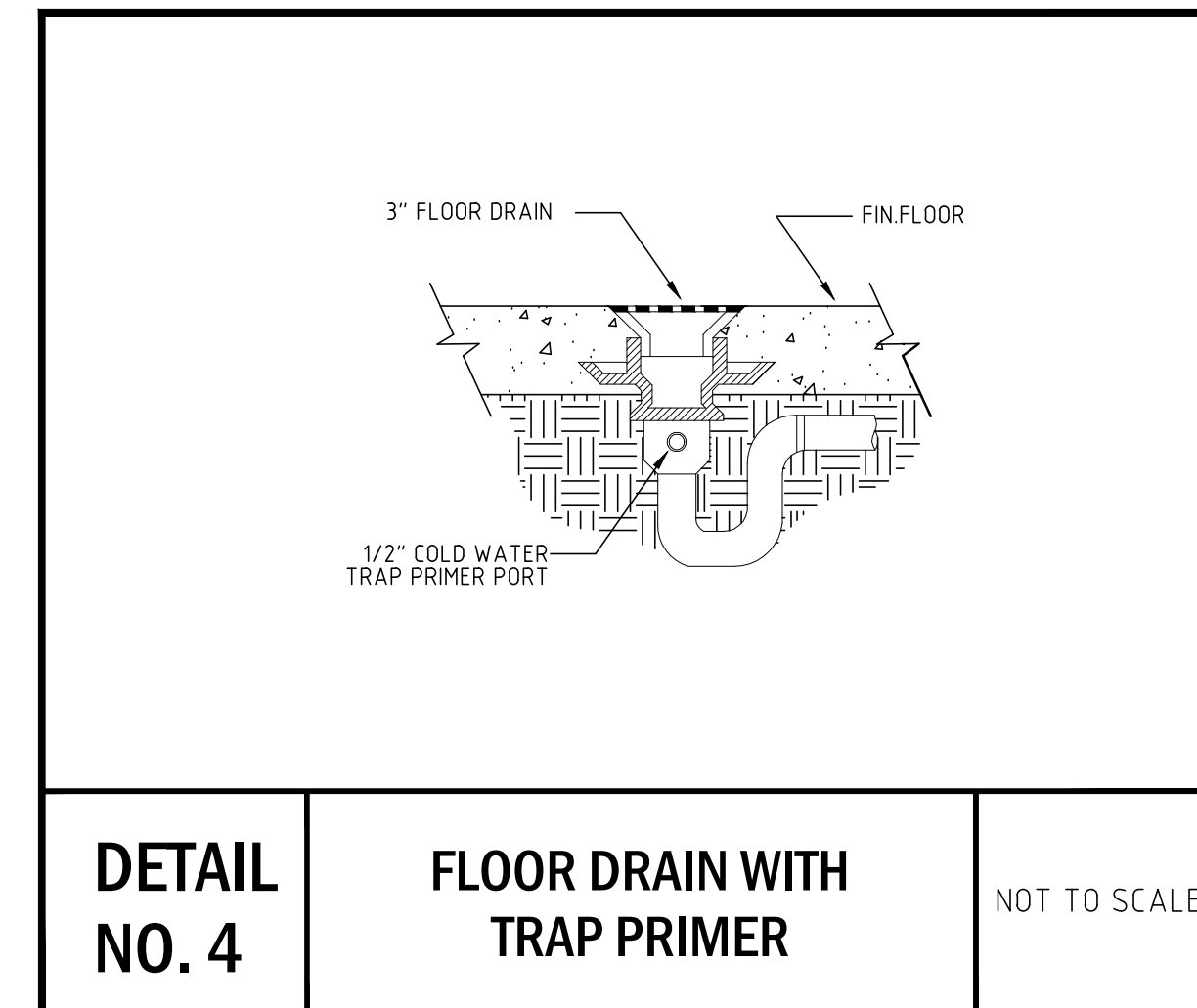

DETAIL NO. 4 FLOOR DRAIN WITH TRAP PRIMER NOT TO SCALE

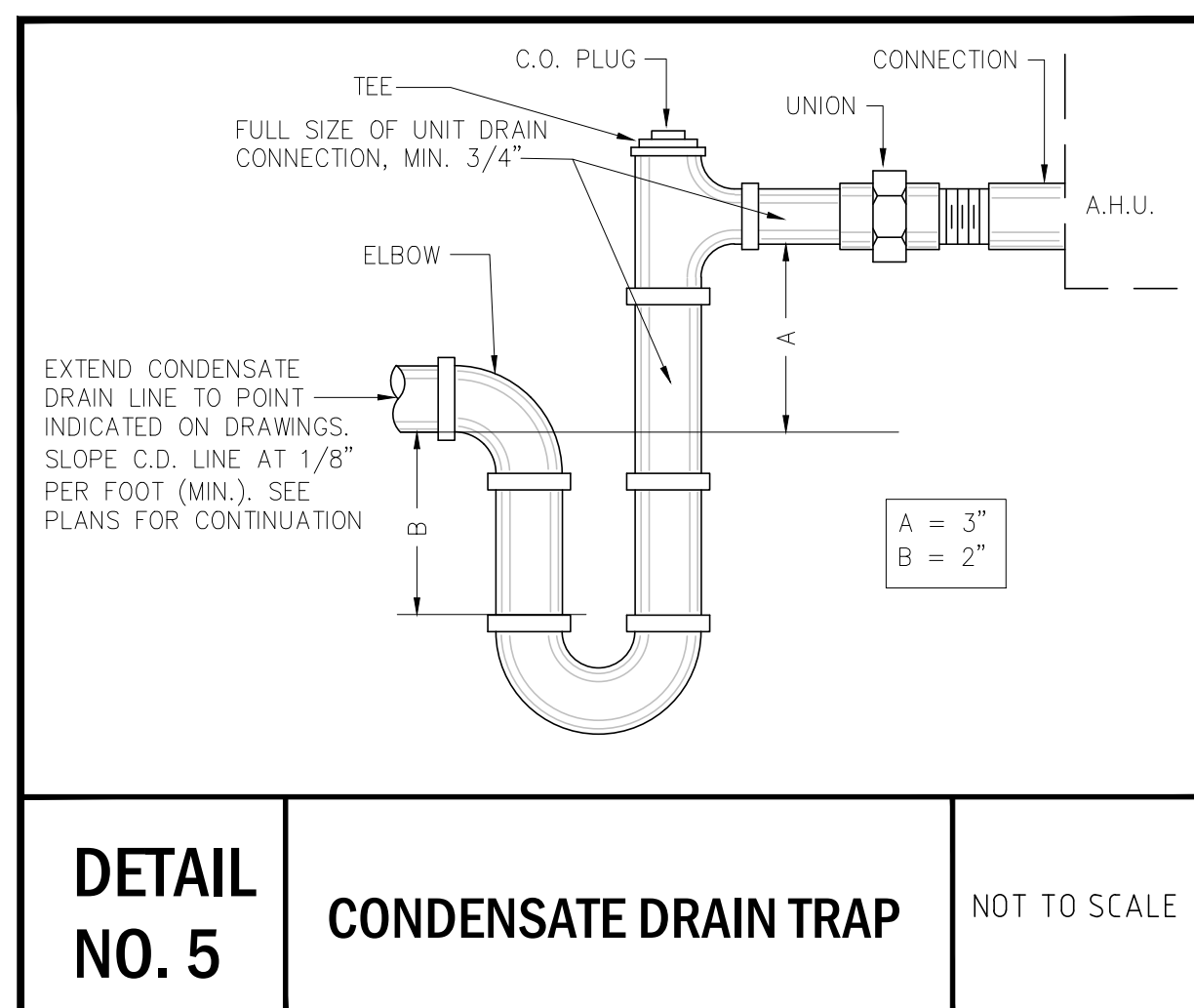

DETAIL NO. 5 CONDENSATE DRAIN TRAP NOT TO SCALE

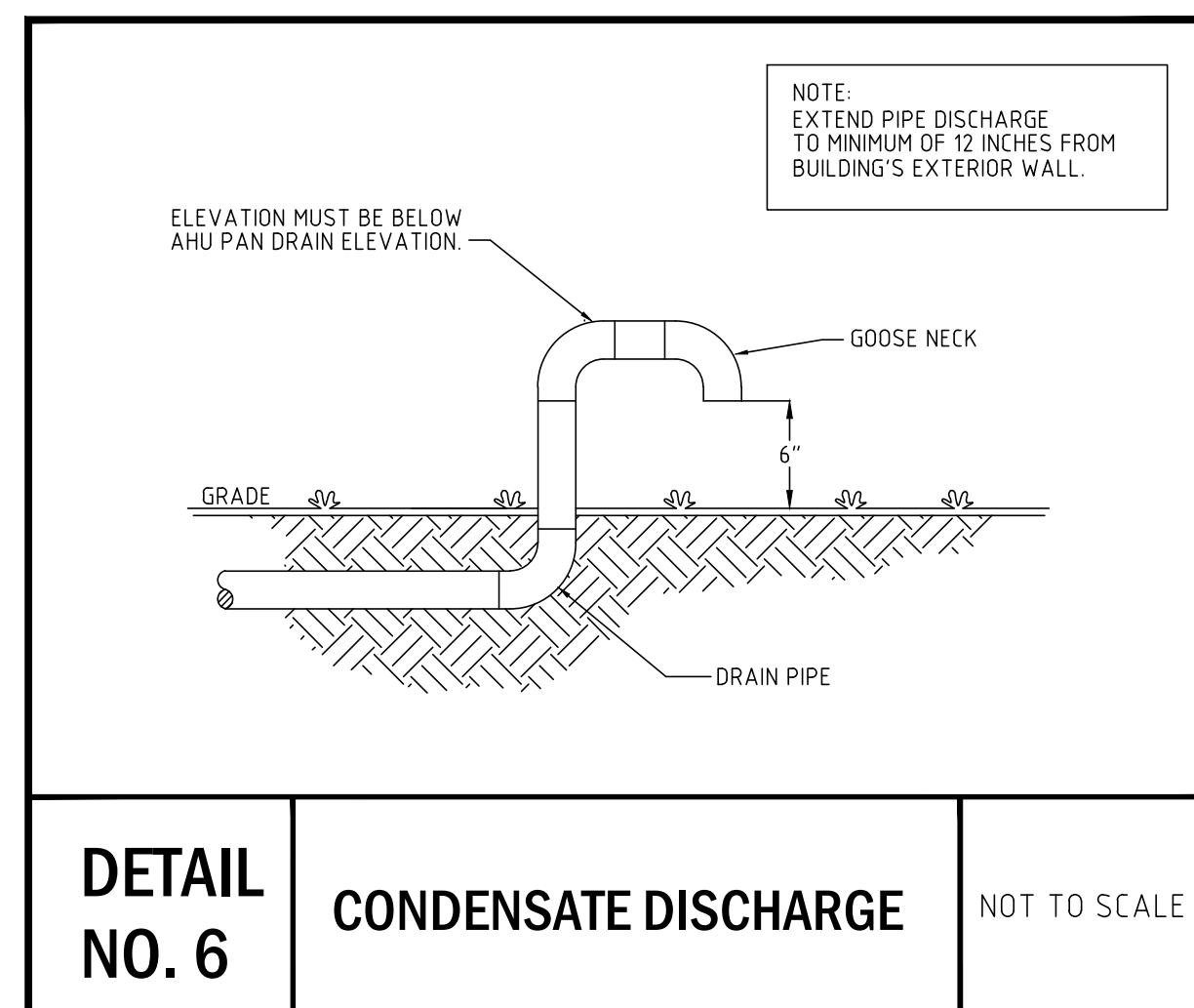

DETAIL NO. 6 CONDENSATE DISCHARGE NOT TO SCALE

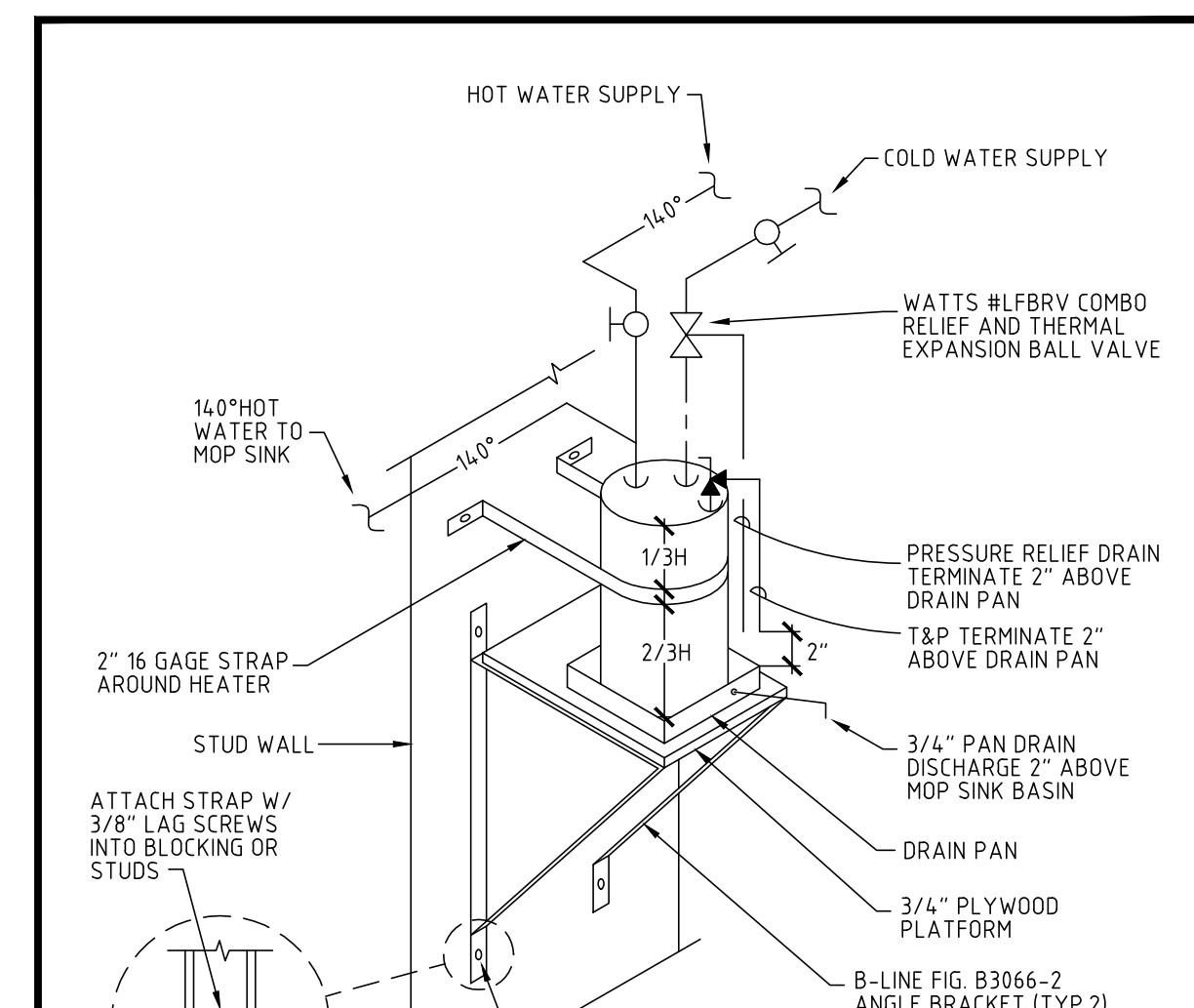

DETAIL NO. 7 WATER HEATER ON PLATFORM NOT TO SCALE

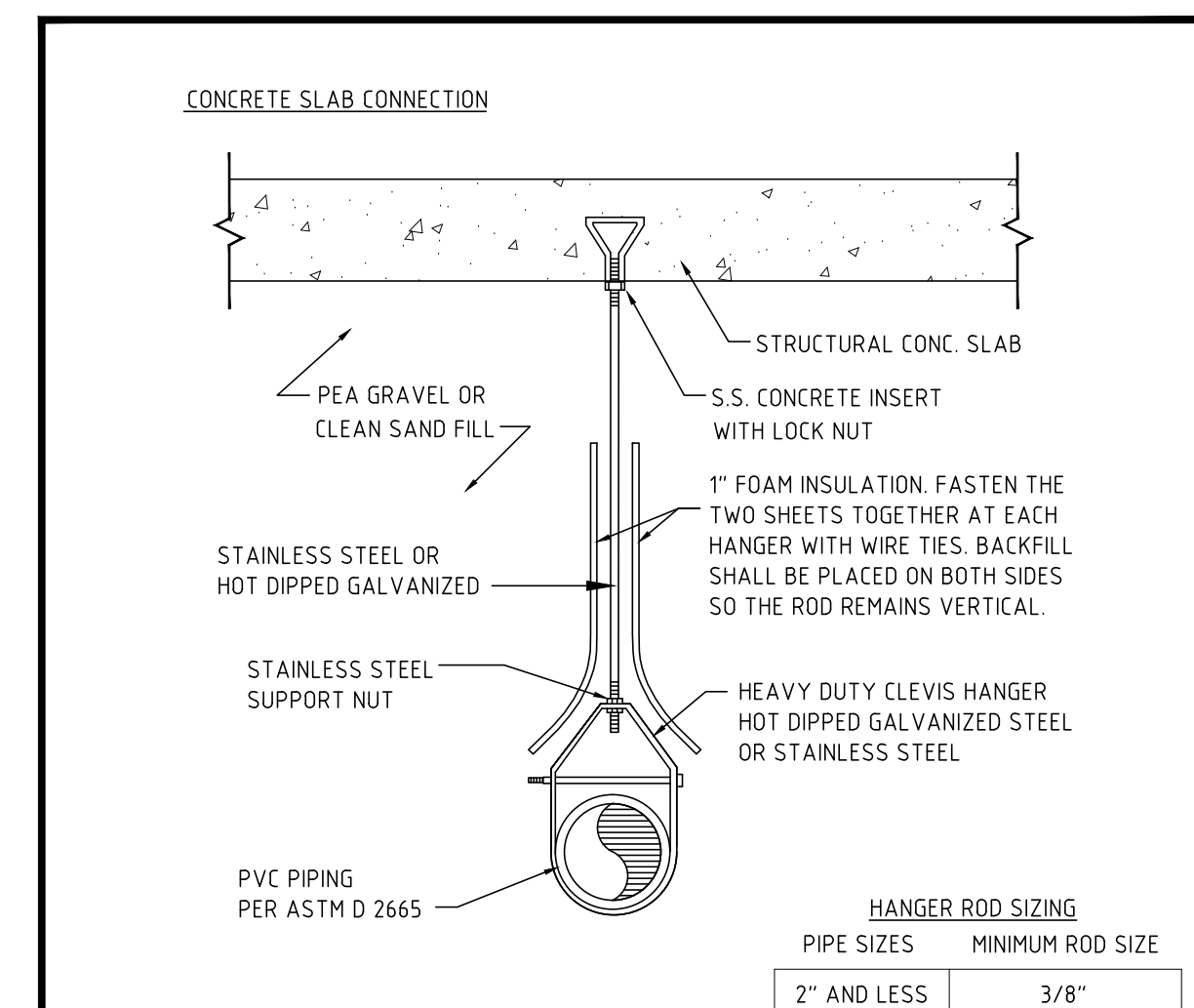

DETAIL NO. 8 PIPE HANGER UNDER STRUCTURAL SLAB NOT TO SCALE

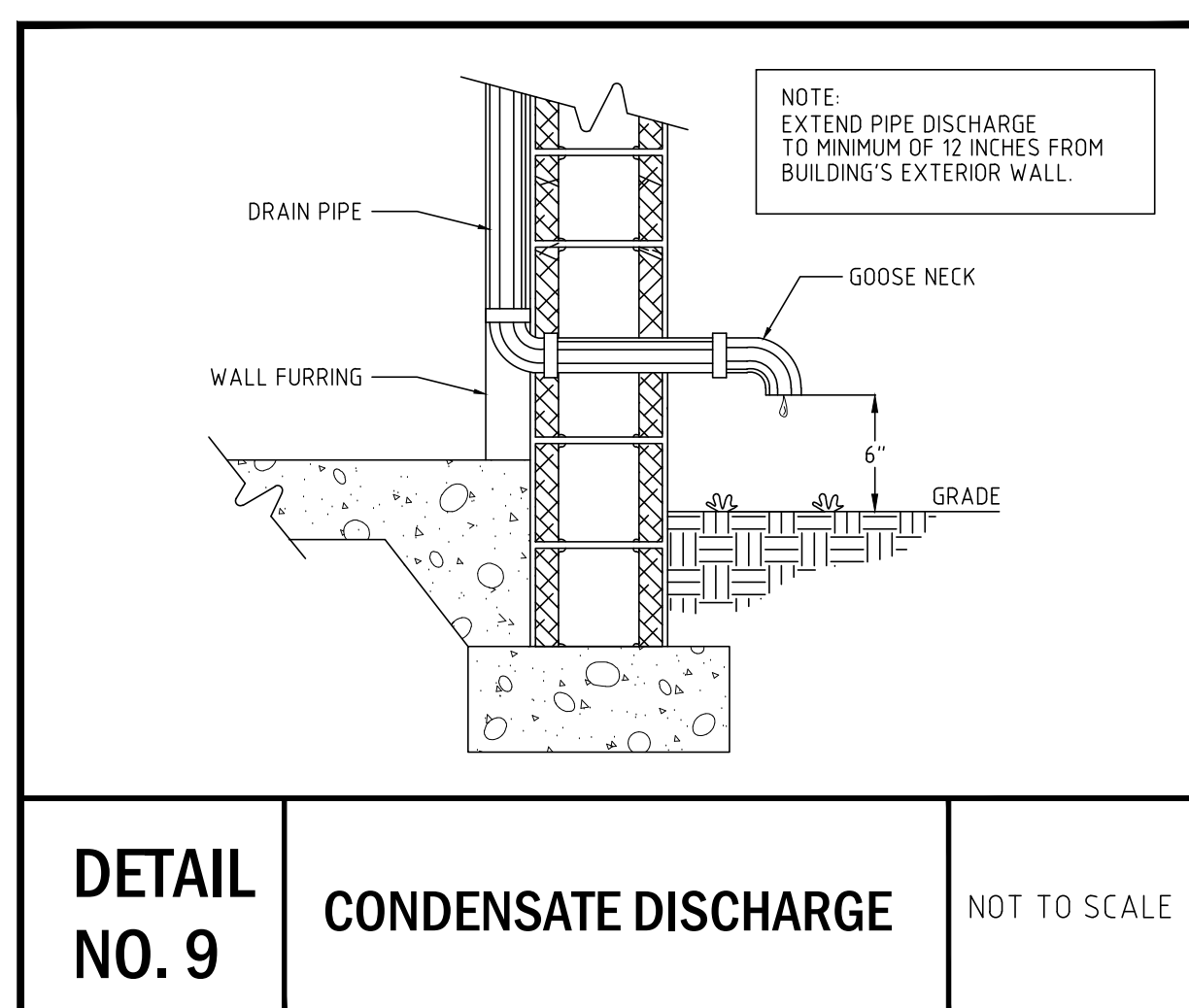

DETAIL NO. 9 CONDENSATE DISCHARGE NOT TO SCALE

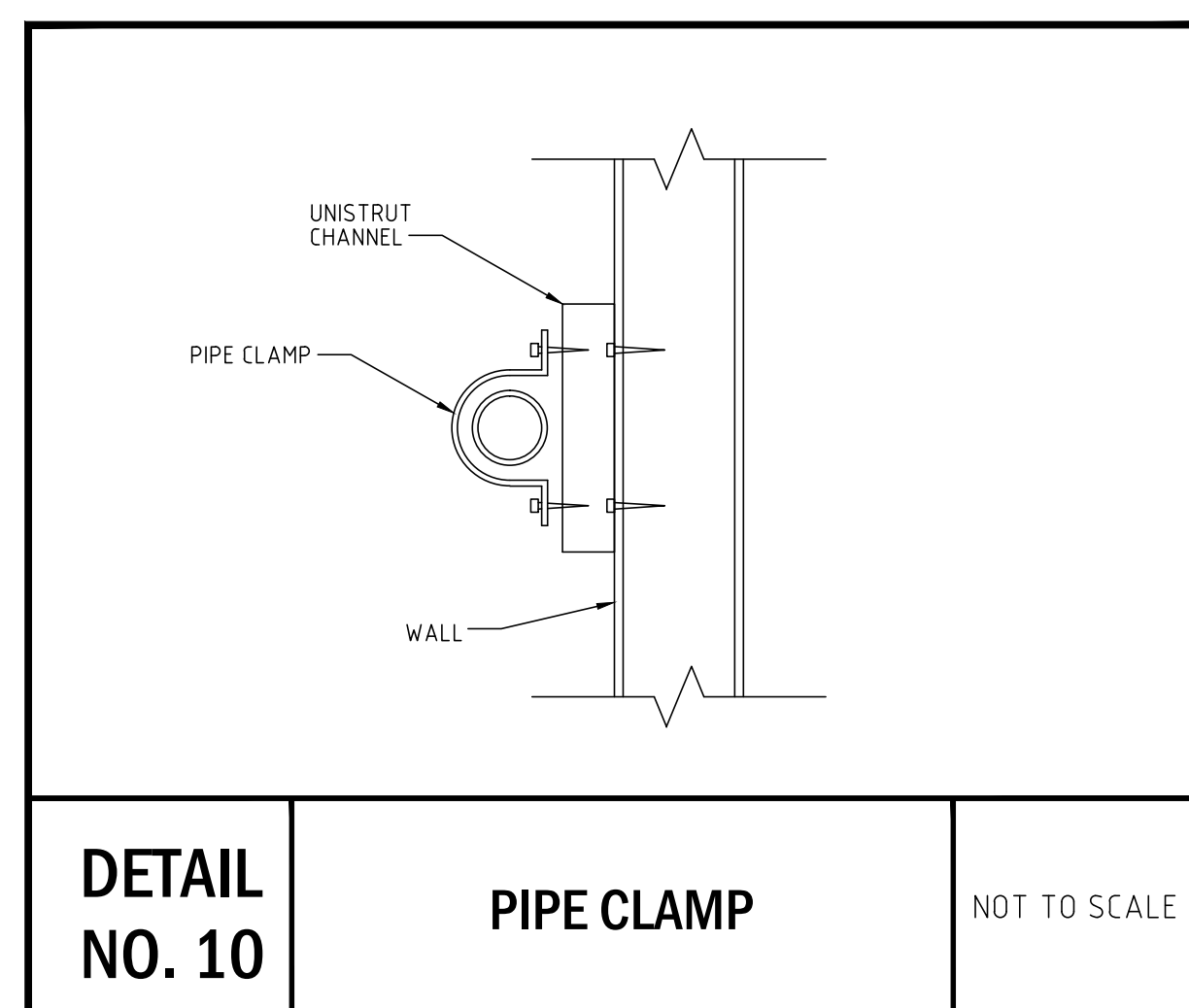

DETAIL NO. 10 PIPE CLAMP NOT TO SCALE

REVISIONS	BY

Slattery & Associates
ARCHITECTS PLANNERS
 2060 NW BOCA RATON BLVD.
 SUITE 2
 BOCA RATON, FL 33431
 TEL: 561-392-3848
 FAX: 561-392-5402
 WWW.SLATTERYARCHITECTS.COM

**WOODFIELD HUNT CLUB
 CLUBHOUSE RENOVATION
 AND EXPANSION**
 4420 WOODFIELD BLVD.
 BOCA RATON, FLORIDA

PLUMBING DETAILS
 CLUBHOUSE BUILDING N.T.S.

PRIOR TO SUBMITTING THE BID, THE CONTRACTOR SHALL FIELD VERIFY ALL EXISTING CONDITIONS AND INFORM THE ARCHITECT AND THE ENGINEER OF ANY DISCREPANCY BETWEEN THESE DOCUMENTS AND THE EXISTING CONDITIONS AND SHALL INCLUDE IN THE BID TO CORRECT THE SAME AS DIRECTED. THE ENGINEER AND THE ARCHITECT, ARE NOT RESPONSIBLE FOR ANY ADDITIONAL COSTS RESULTING FROM VERIFIABLE EXISTING CONDITIONS DISCOVERED AFTER CONTRACT HAS BEEN AWARDED. NO CHANGES SHALL BE MADE TO THESE PLANS WITHOUT PRIOR APPROVAL FROM THE ENGINEER OF RECORD. ALL CHANGES SHALL BE SUBMITTED FOR REVIEW PRIOR TO INSTALLATION. NOT FOR BID UNTIL PERMIT HAS BEEN ISSUED.

PERMIT SET: 07/21/16

FAE CONSULTING
 700 WEST HILLSBORO BLVD., BLDG. #1, SUITE 204
 DEERFIELD BEACH, FLORIDA 33441
 TEL: (561) 391-9292 FAX: (561) 391-9898
 CERTIFICATE OF AUTHORIZATION NO. 28107
 URSULA IARFATE, P.E. LICENSE #73122
 STEPHEN F. ROLLIN, P.E. LICENSE #36428
 DONALD H. AUSTIN, JR., P.E. LICENSE #60651
 JASON BARBER, P.E. LICENSE #73050
 E-MAIL: INFO@FAECONSULTING.COM
 DESIGNED BY: DB/FR/AB PM: KS P/N: 16104

DRAWN DB/FR/AB
 CHECKED UI/SR/DA/UB
 DATE 07-21-16
 SCALE AS NOTED
 JOB NO. 16104
 SHEET

P0.2

PERMIT - 7-21-16

X:\2016 Projects\Slattery & Associates\16104_Woodfield Hunt Club Renovation\MEP\16-06-30_TN\16104_P1.1.dwg, P0.2, 7/21/2016 4:34:00 PM, TNguyen