

STANDARD MANHOLE WITH CAST-IN LINER 18S

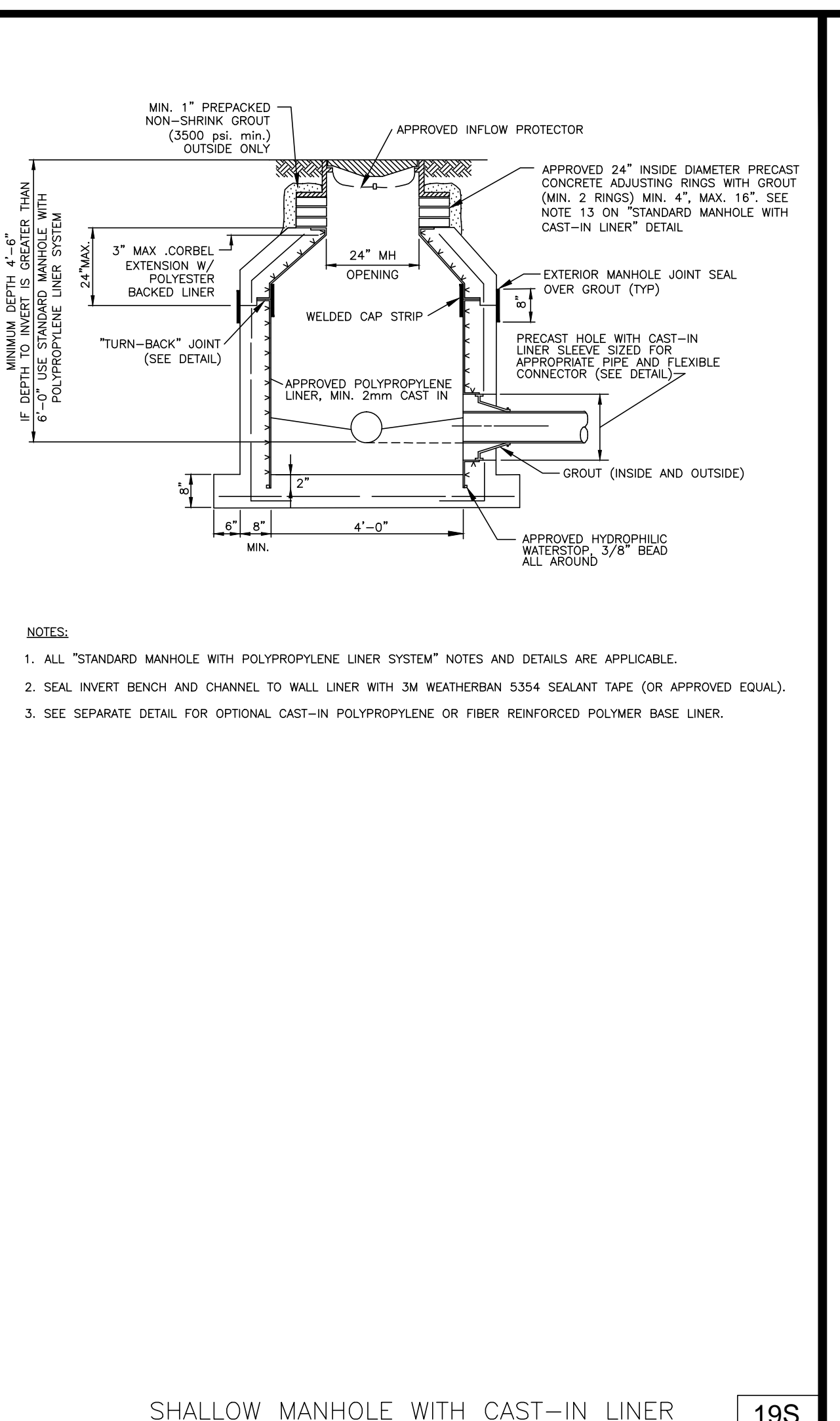

SHALLOW MANHOLE WITH CAST-IN LINER 19S

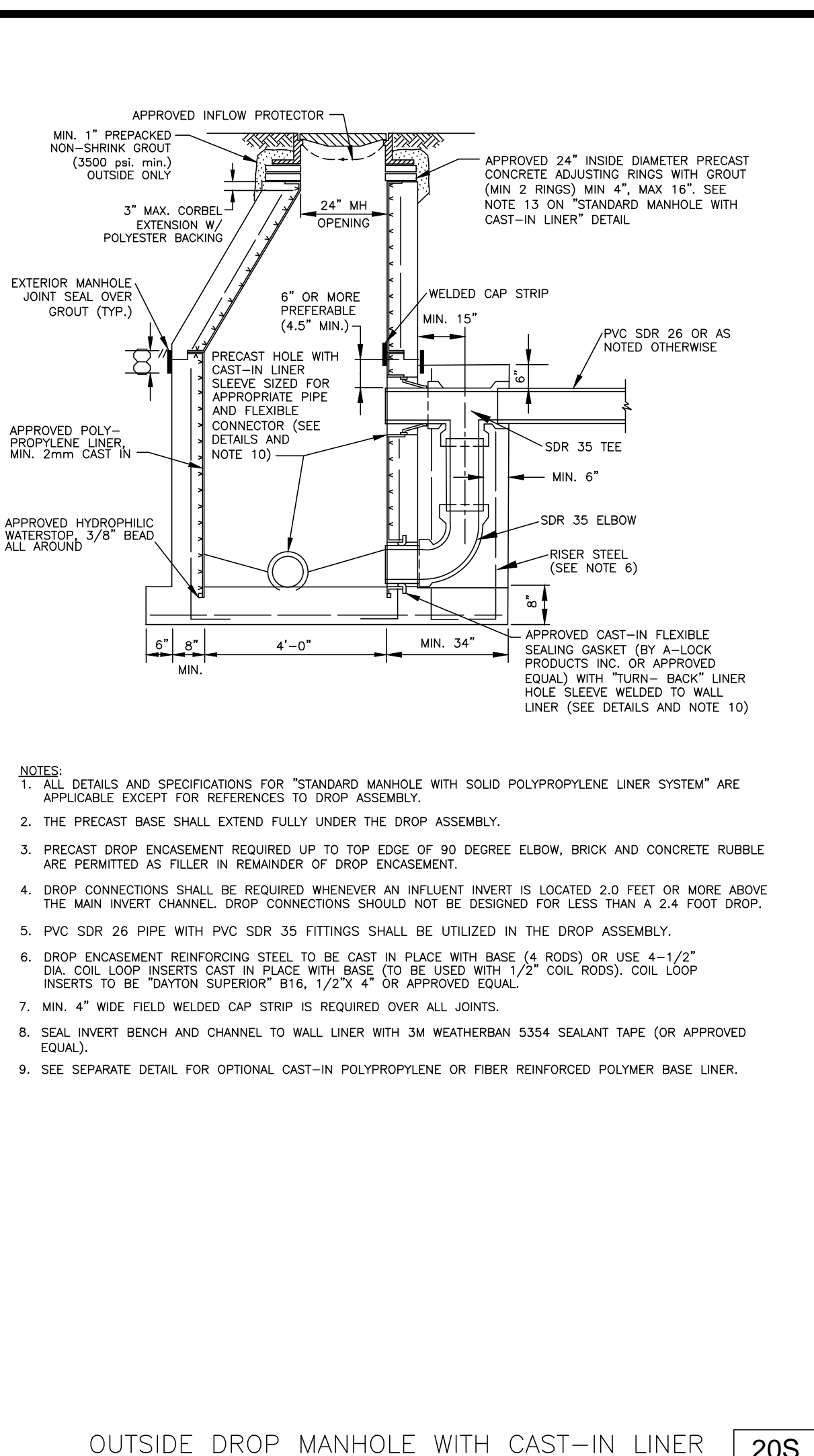

OUTSIDE DROP MANHOLE WITH CAST-IN LINER 20S

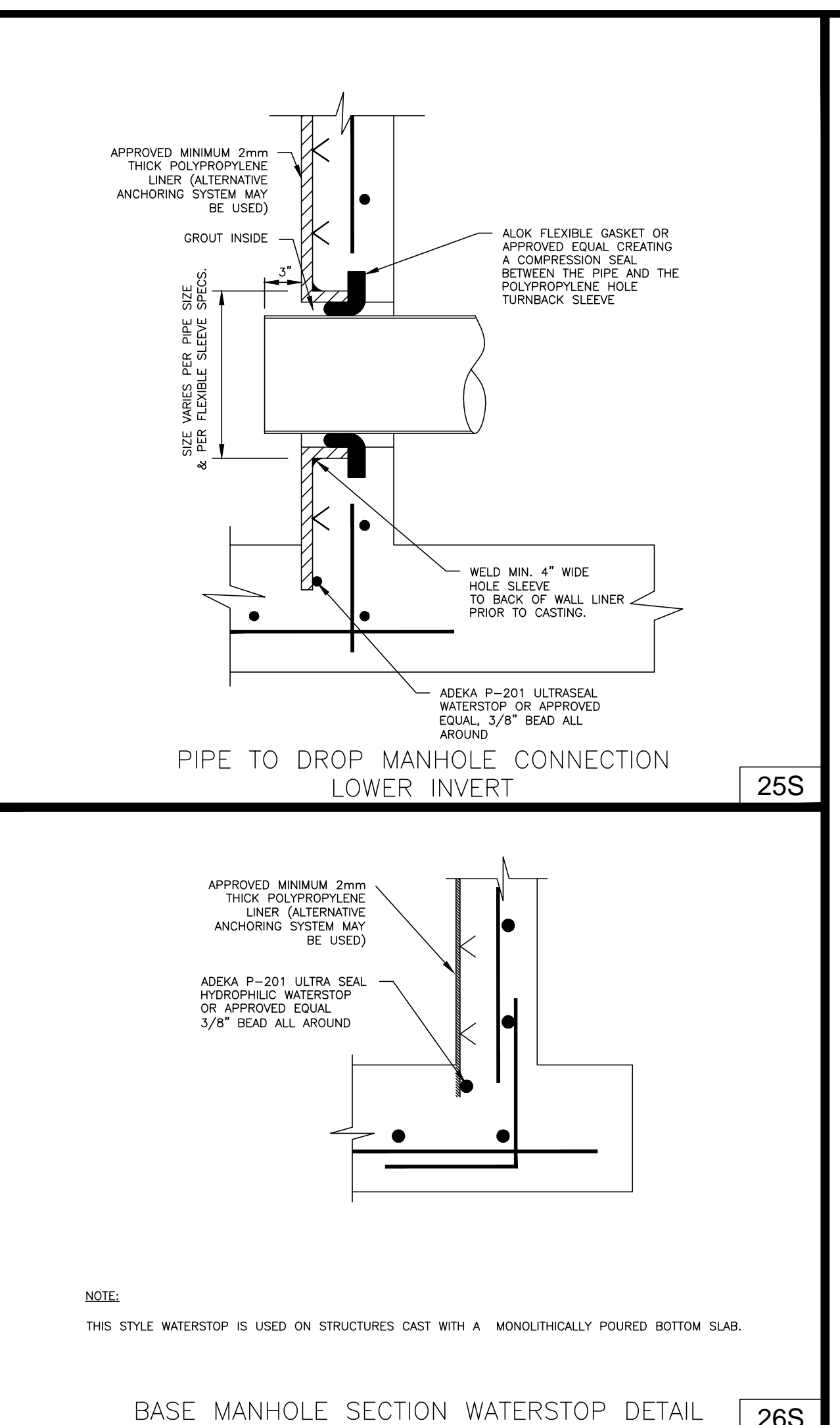

PIPE TO DROP MANHOLE CONNECTION LOWER INVERT 25S

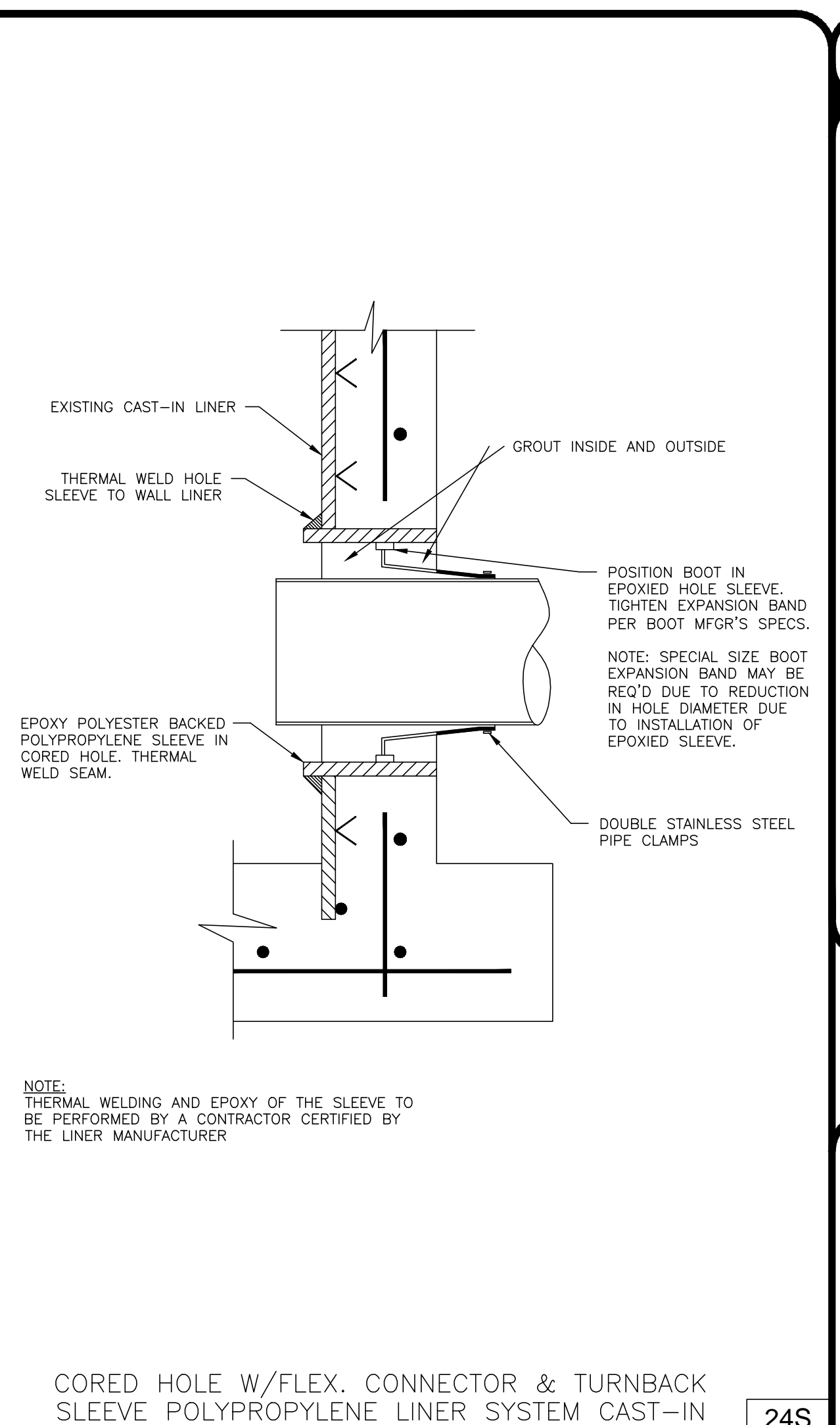

CORED HOLE W/FLEX. CONNECTOR & TURNBACK SLEEVE POLYPROPYLENE LINER SYSTEM CAST-IN 24S

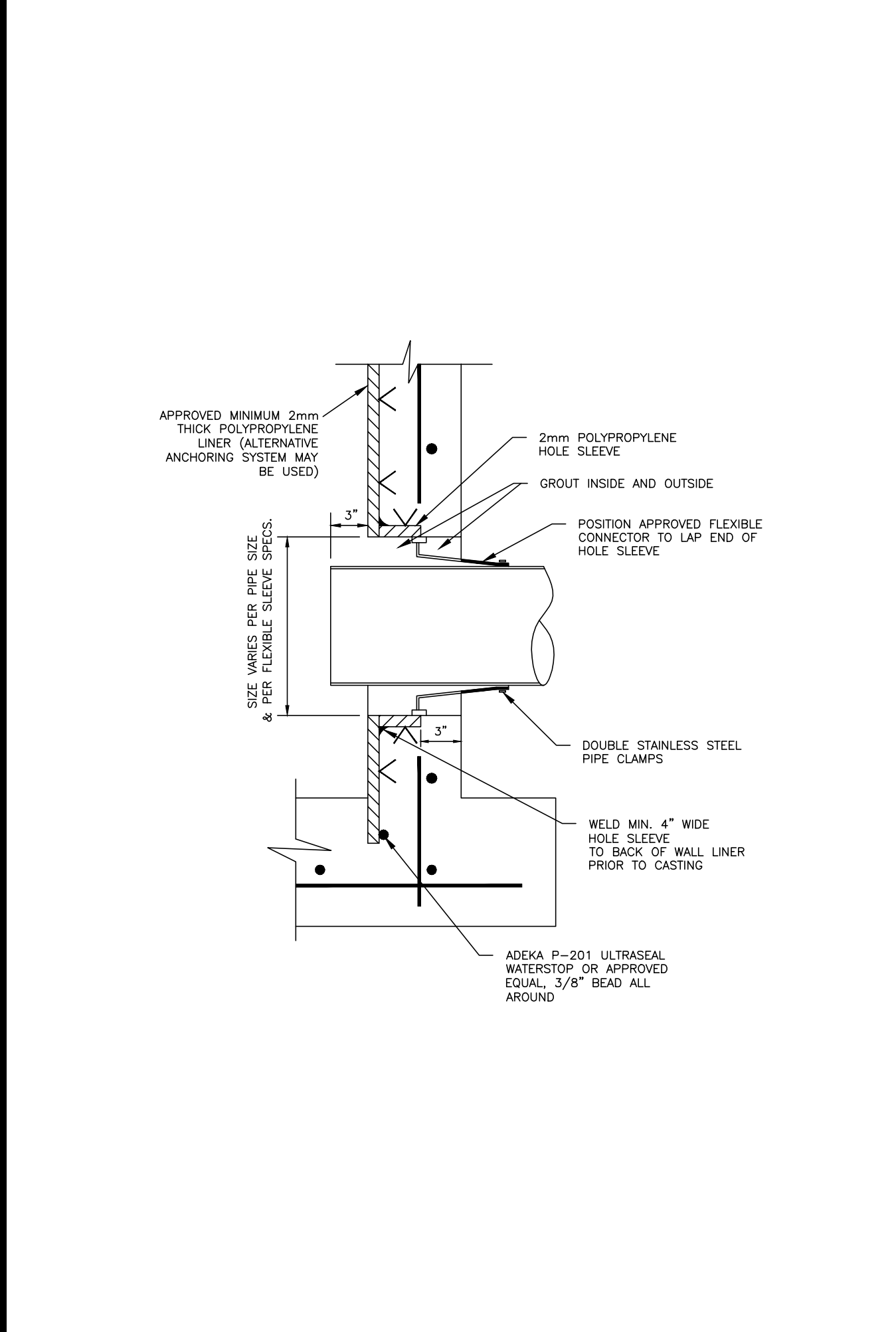

PIPE TO MANHOLE CONNECTION - TYPE "A" 21S

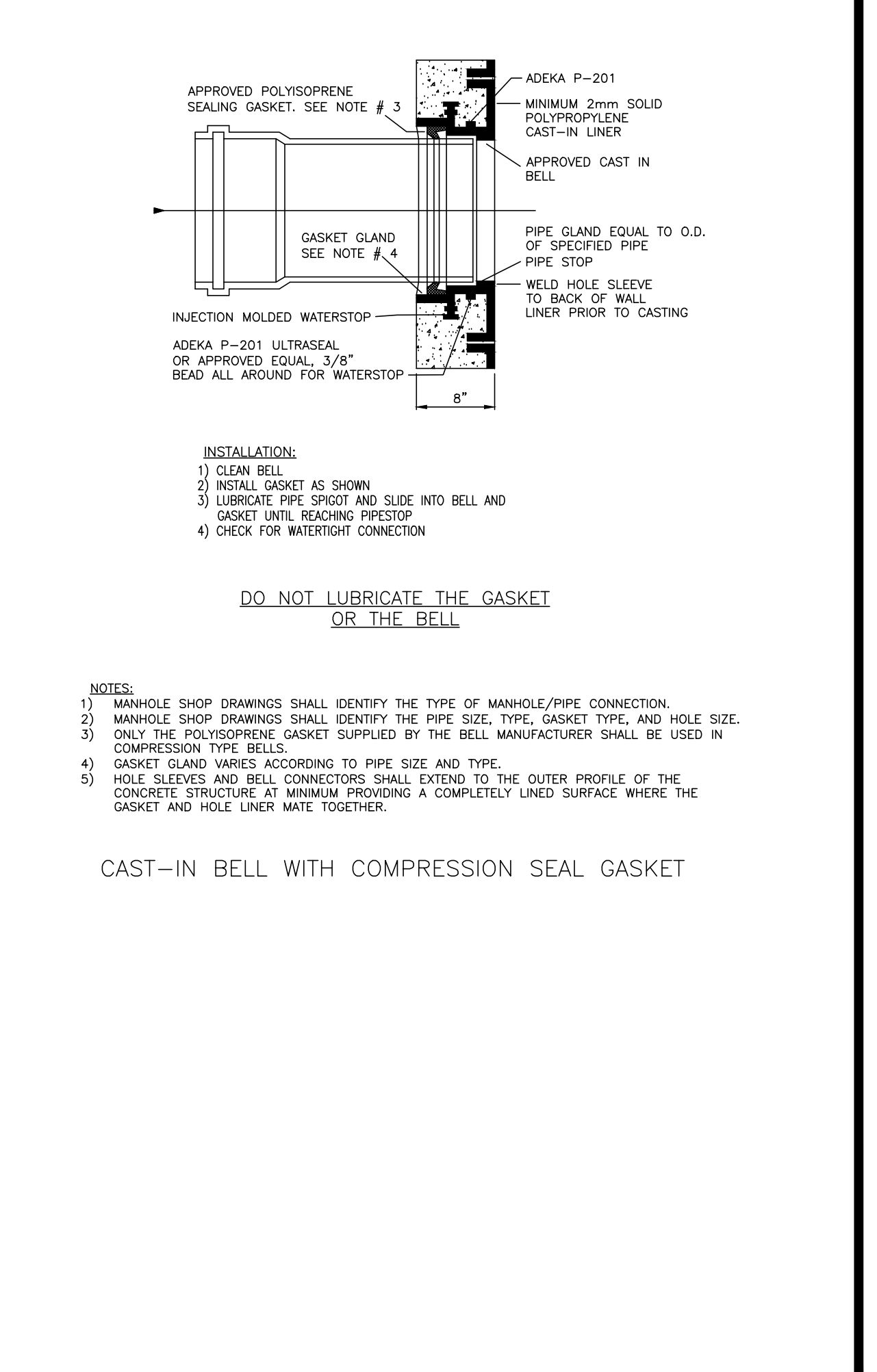

PIPE TO MANHOLE CONNECTION - TYPE "B" 22S

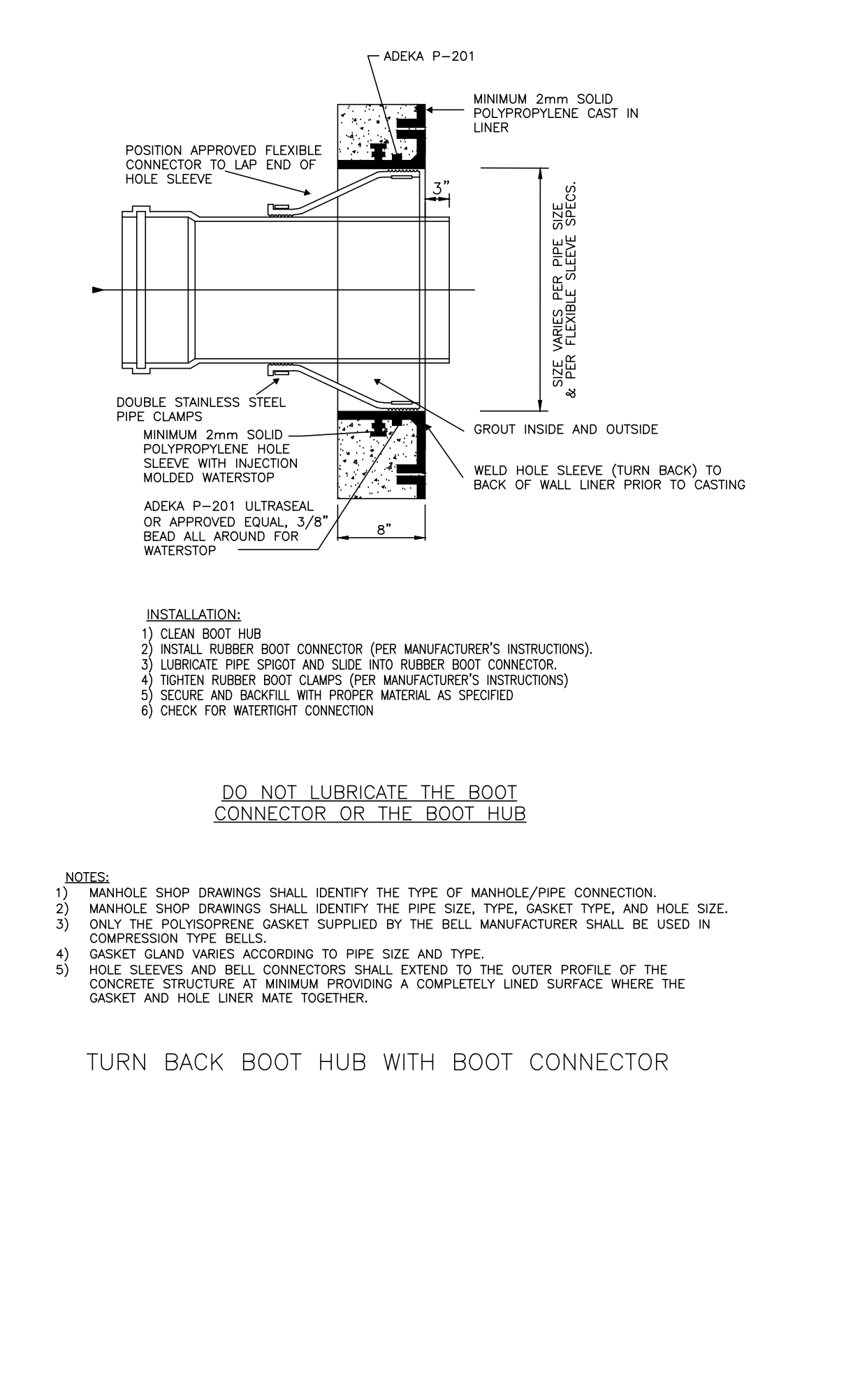

TURN BACK BOOT HUB WITH BOOT CONNECTOR 23S

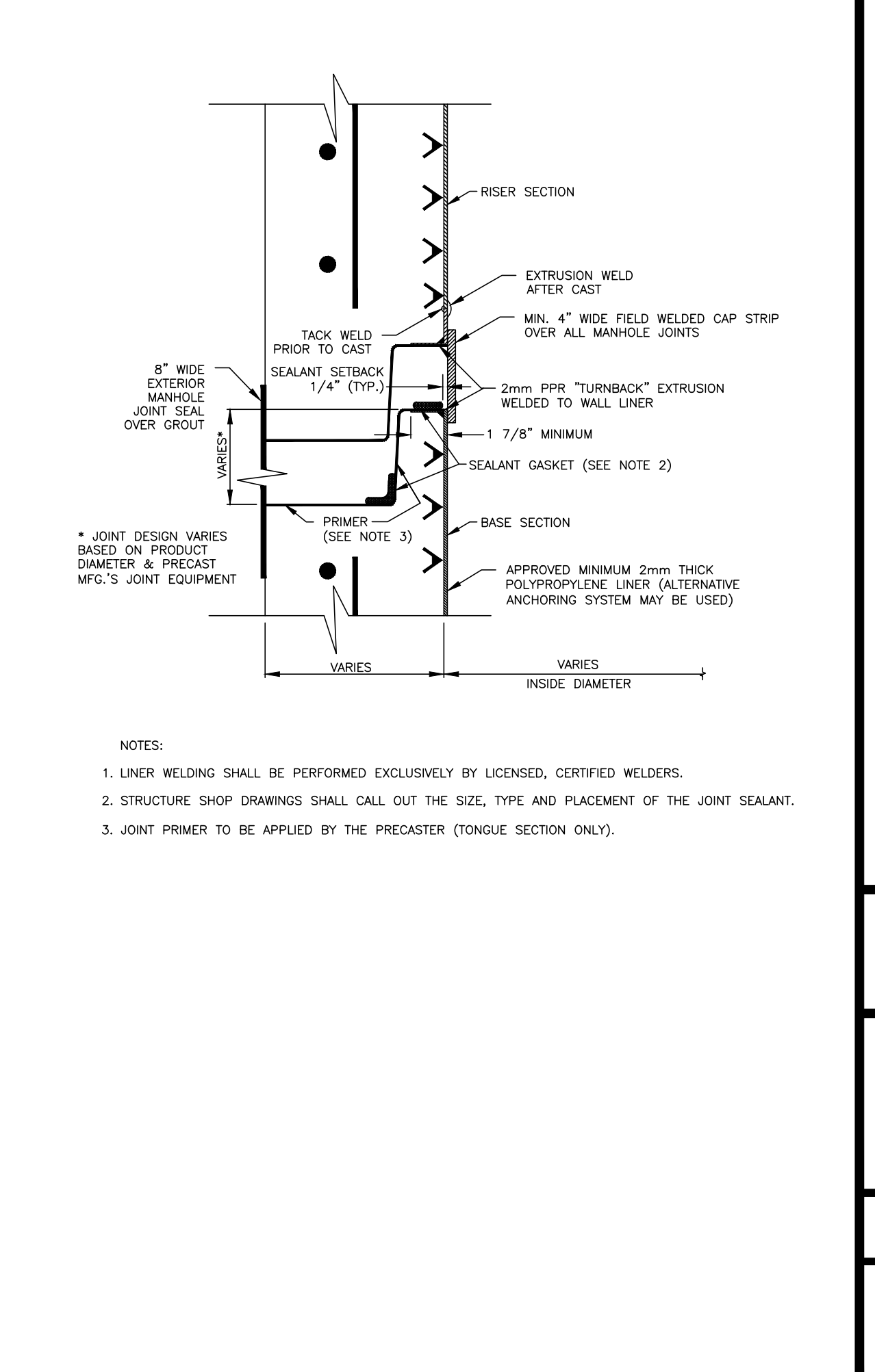

TURN BACK JOINT INSTALLED PRIOR TO CAST 27S

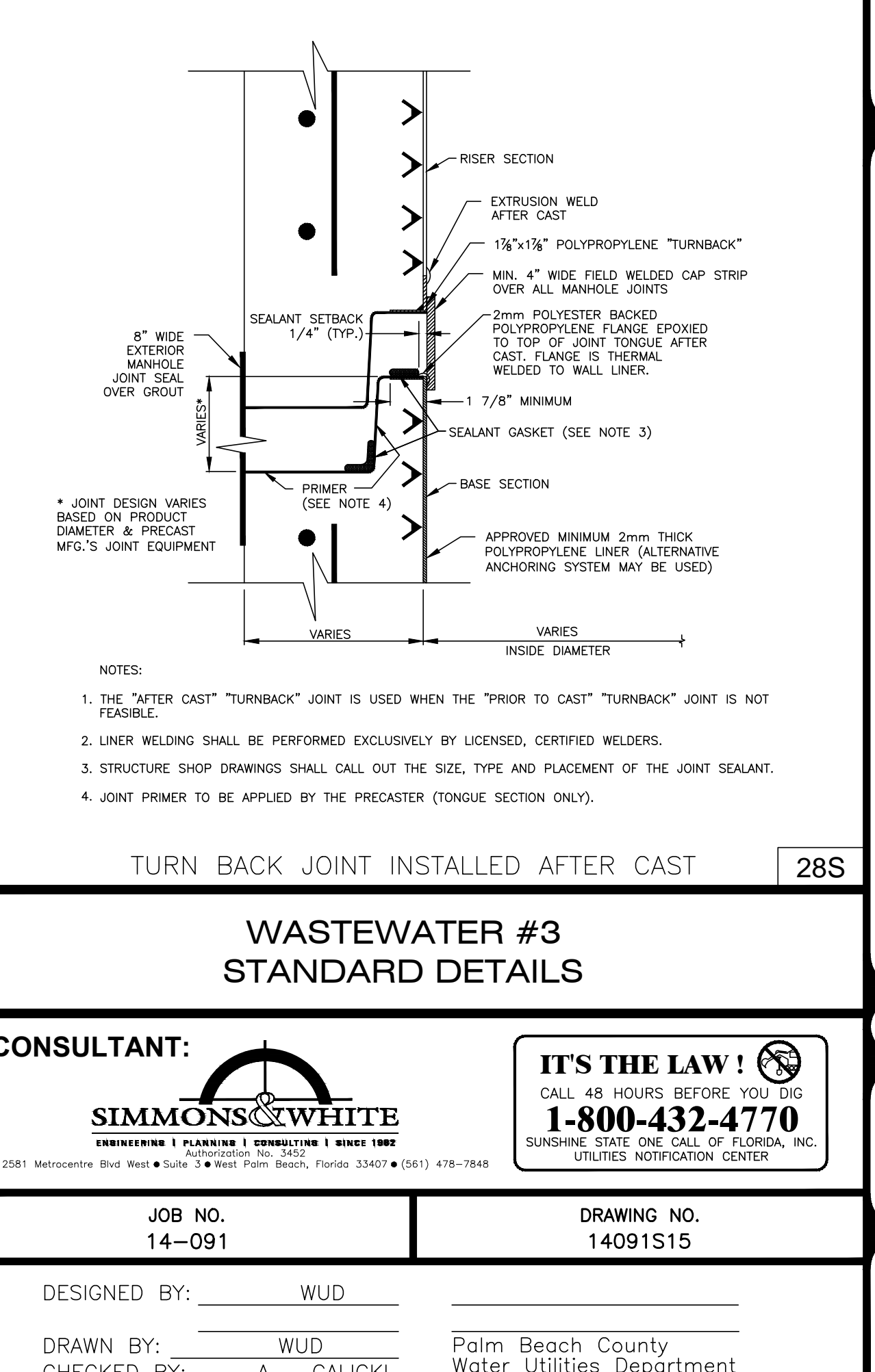

TURN BACK JOINT INSTALLED AFTER CAST 28S