

CONNECTION OF PRIVATE FORCE MAIN UNDER 4" IN DIAMETER 37S

TYPICAL FORCE MAIN GATE VALVE SETTING AND CUT-IN DETAIL 38S

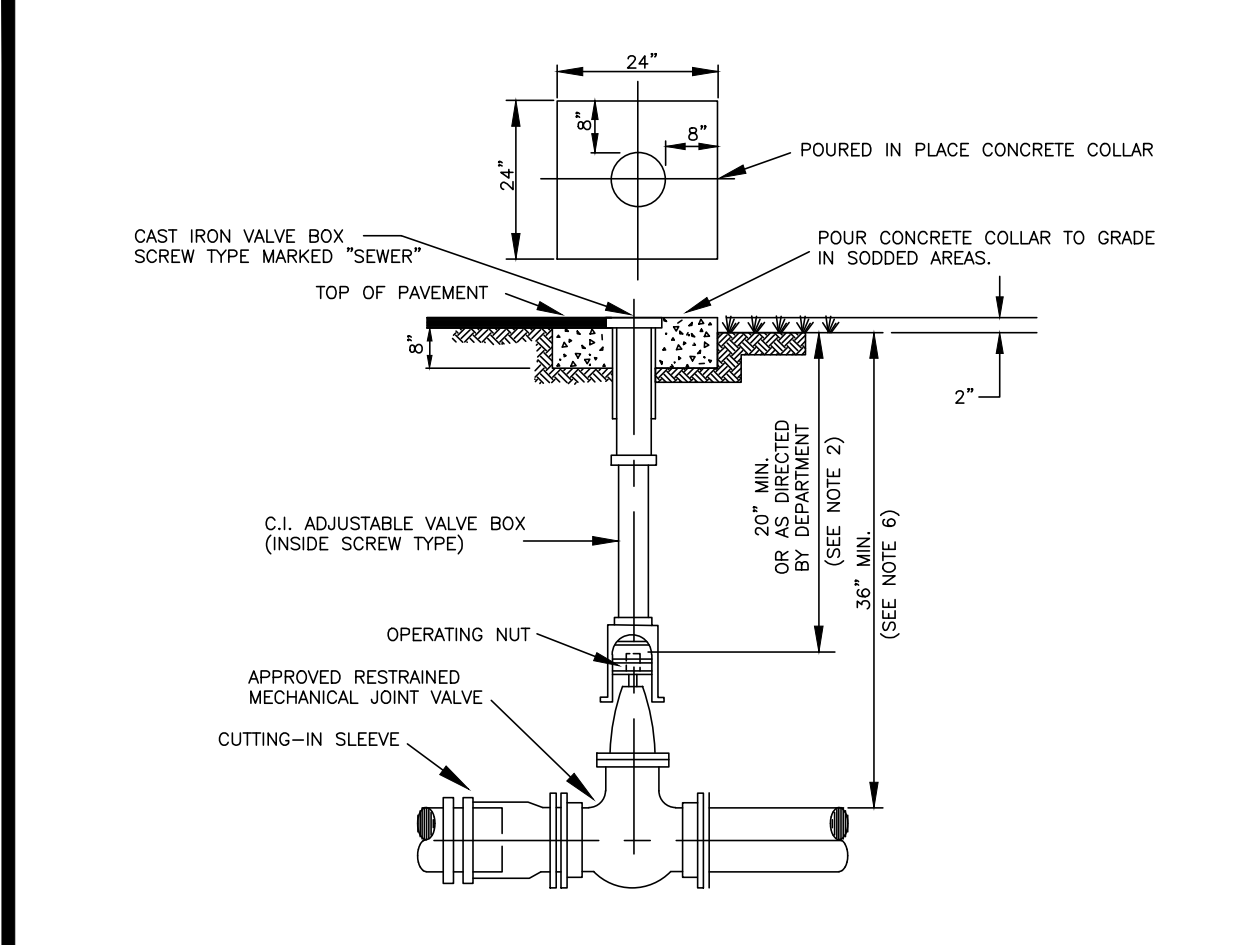

FORCE MAIN AIR RELEASE VALVE AND VAULT OUTSIDE OF R/W, NON-TRAFFIC AREAS OUTSIDE OF R/W 39S

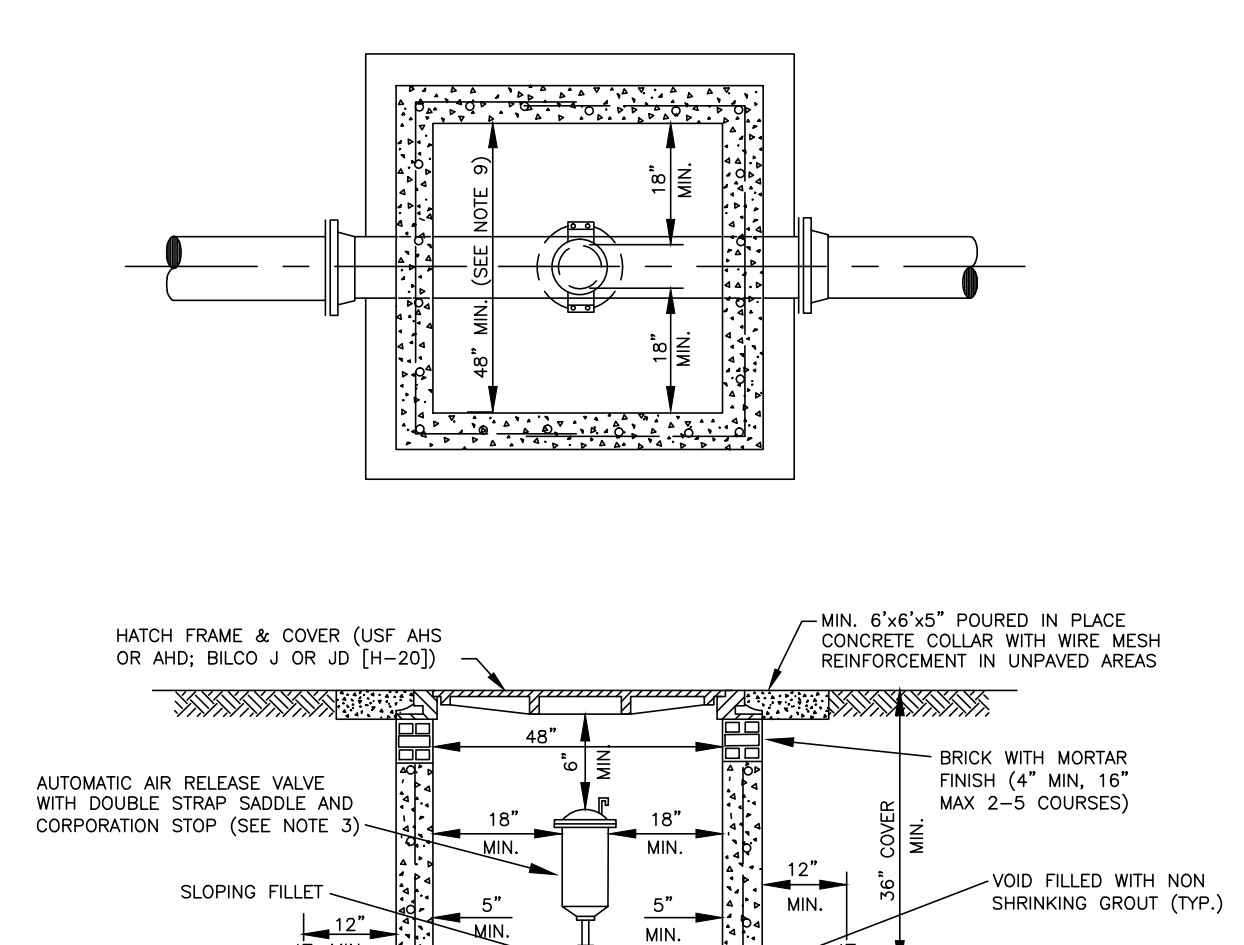

FORCE MAIN AIR RELEASE VALVE AND MANHOLE IN PAVED AREAS AND ROAD R/W 40S

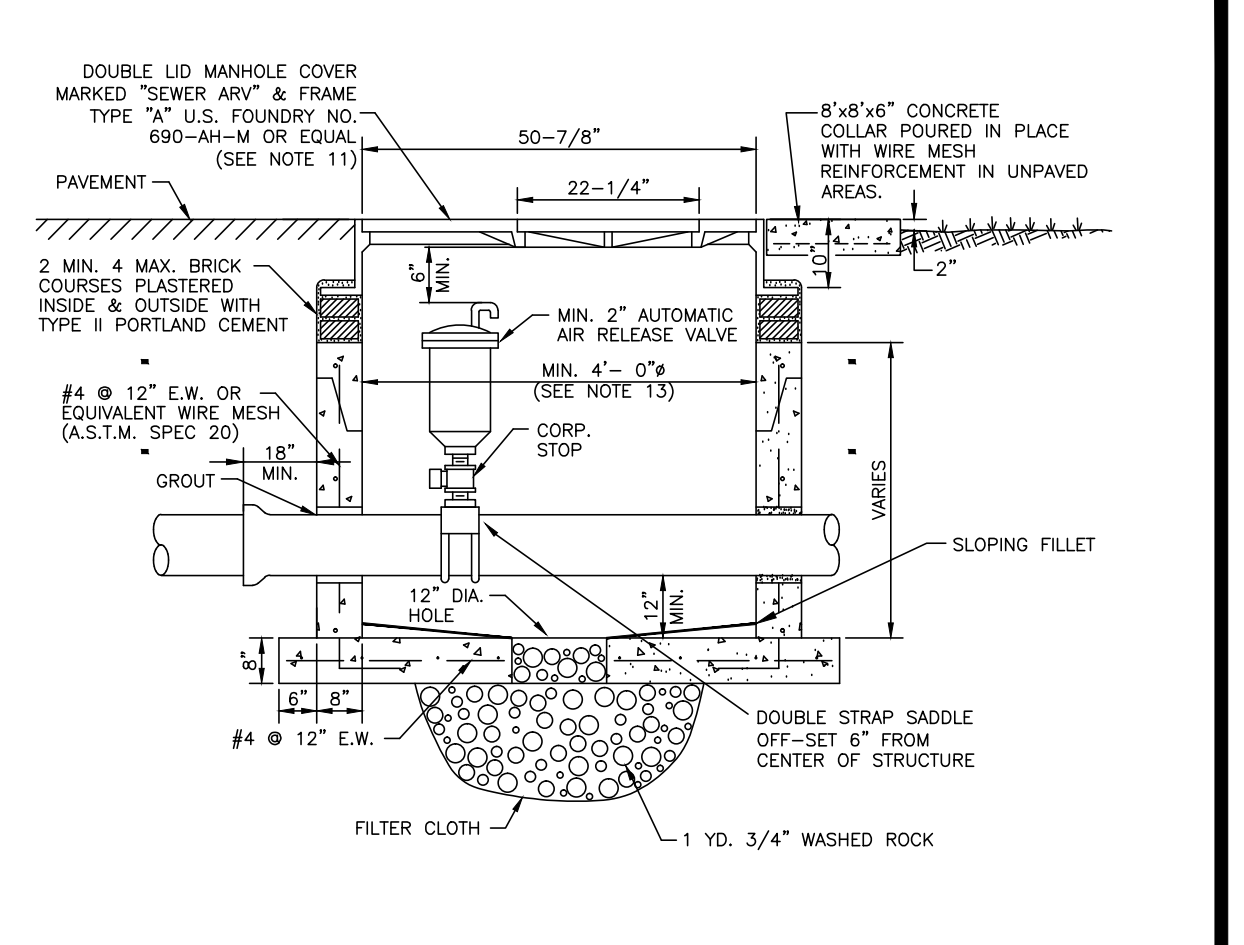

MECHANICAL THRUST RESTRAINT MINIMUM PIPE LENGTHS (FORCE MAINS) 41S

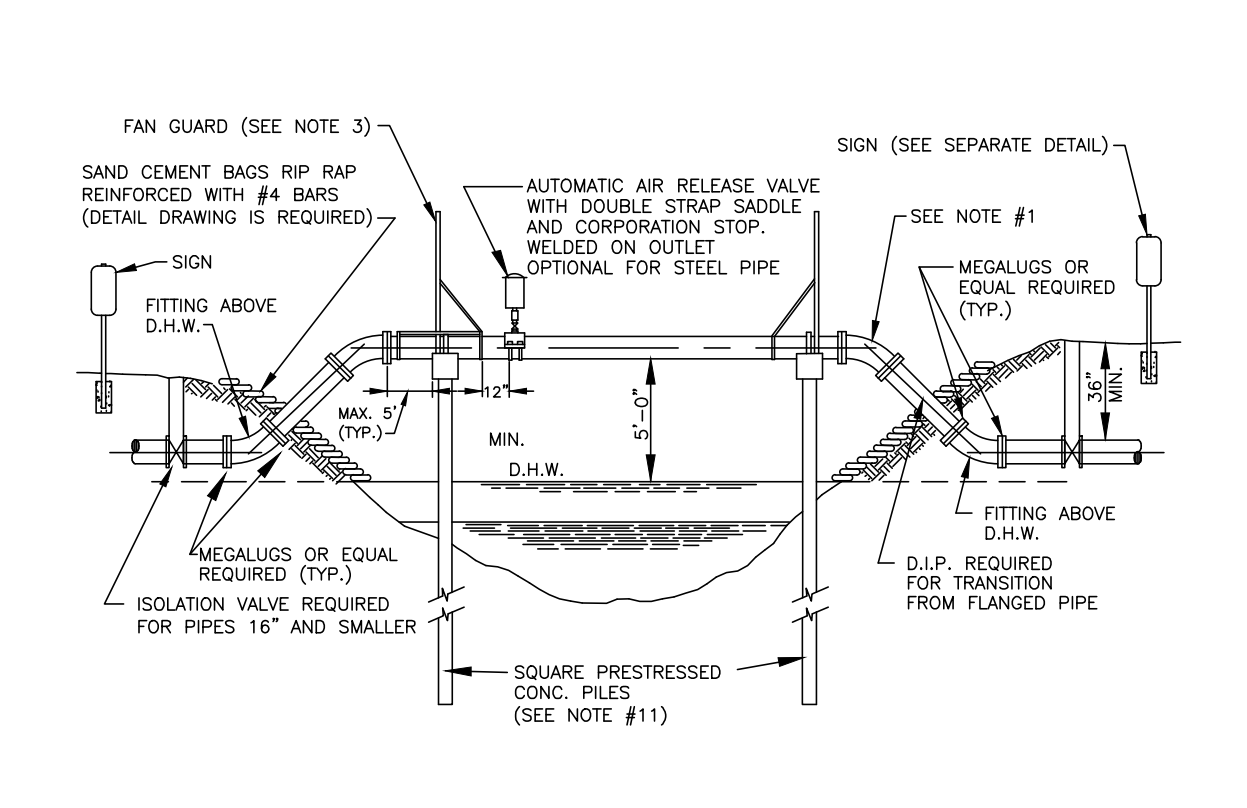

TYPICAL FORCE MAIN AERIAL CANAL CROSSING - SINGLE PIPE (SINGLE PILES) 45S

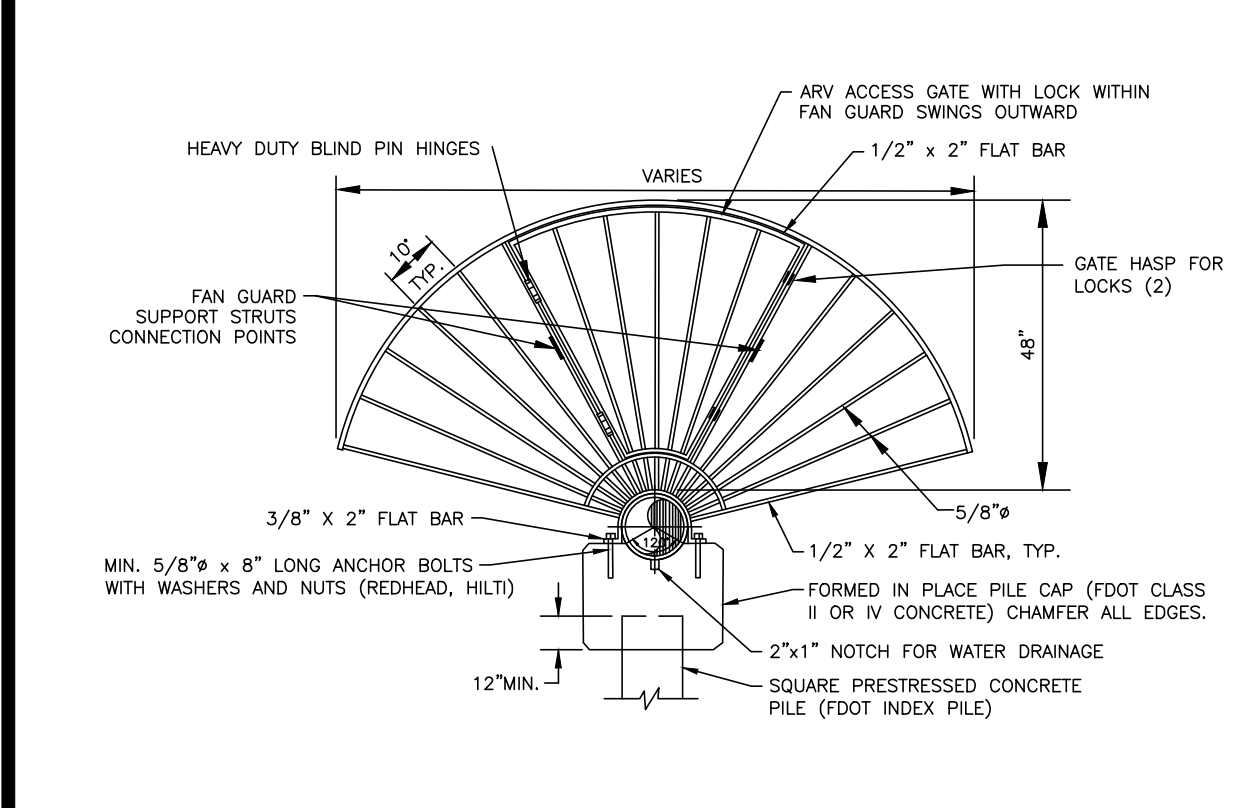

FAN GUARD/ PILE CAP DESIGN - SINGLE PIPE (SINGLE PILES) 46S

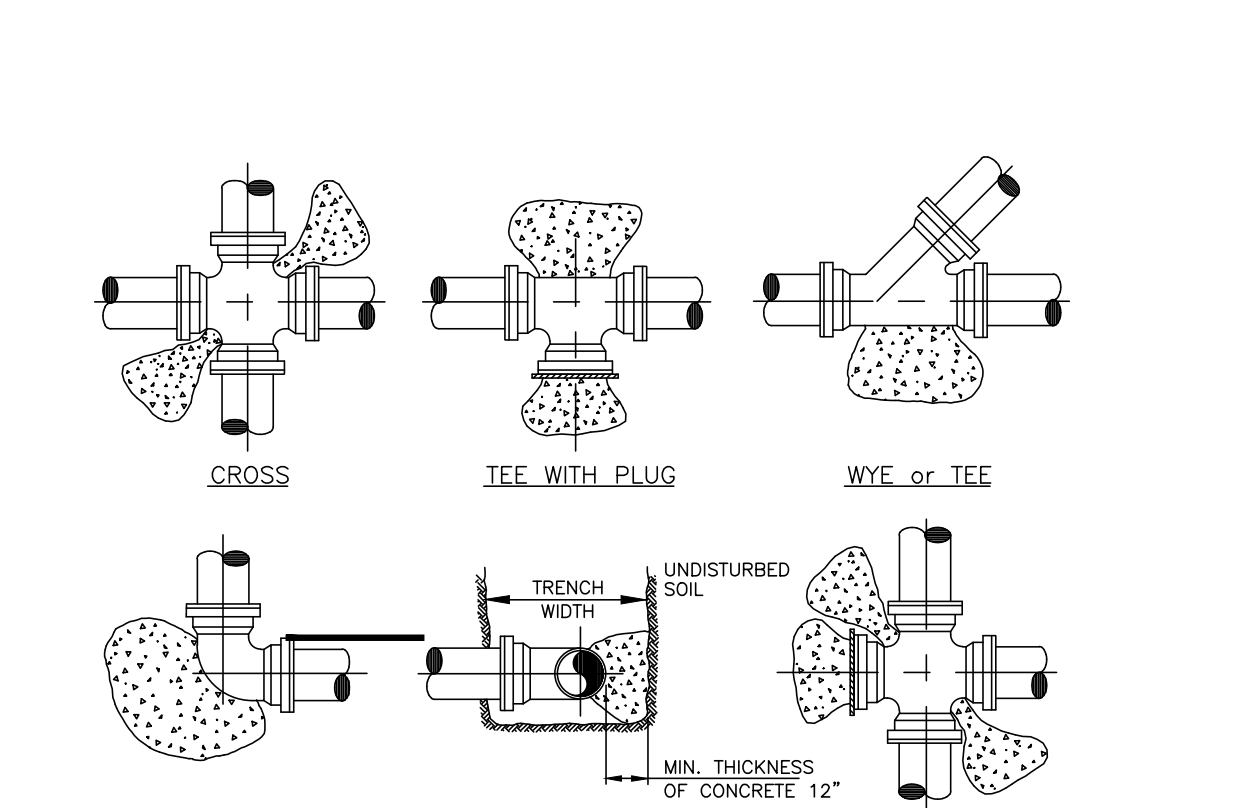

TYPICAL THRUST BLOCKS FOR PRESSURE PIPING 42S

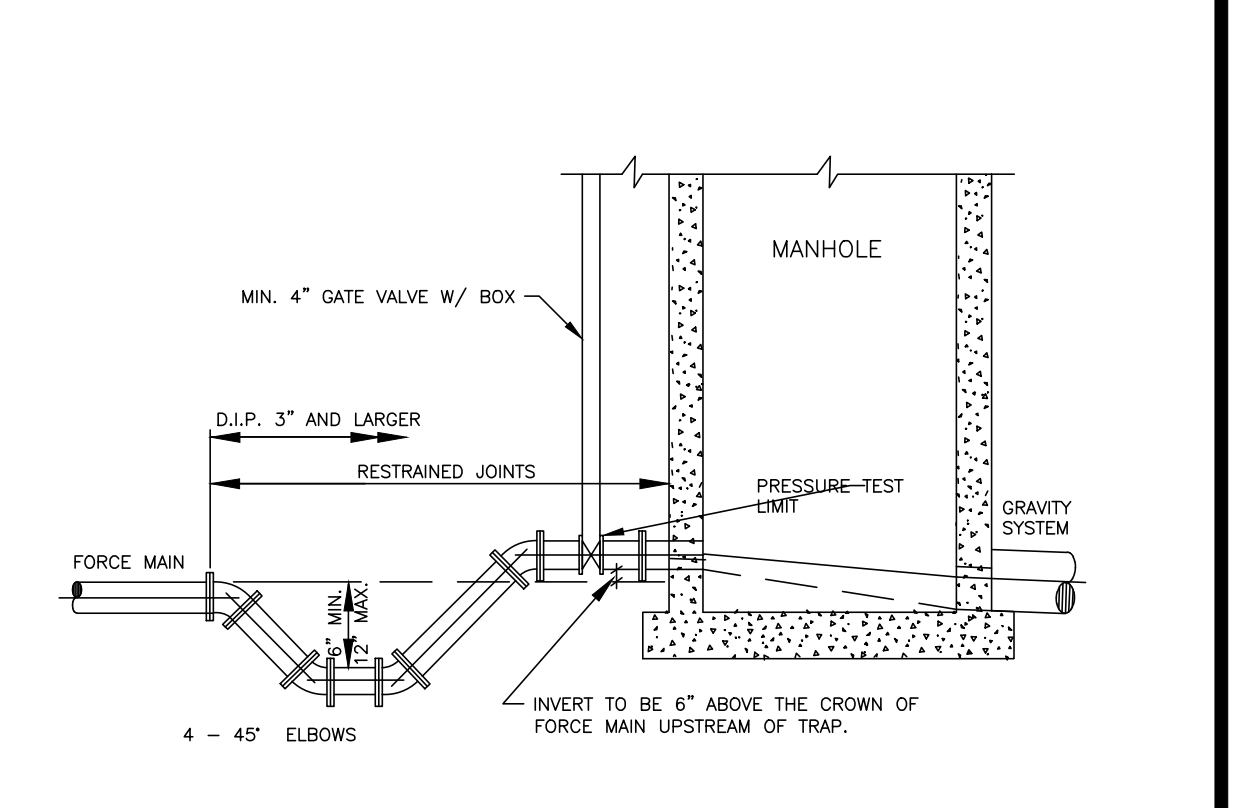

FORCE MAIN ENTERING MANHOLE 43S

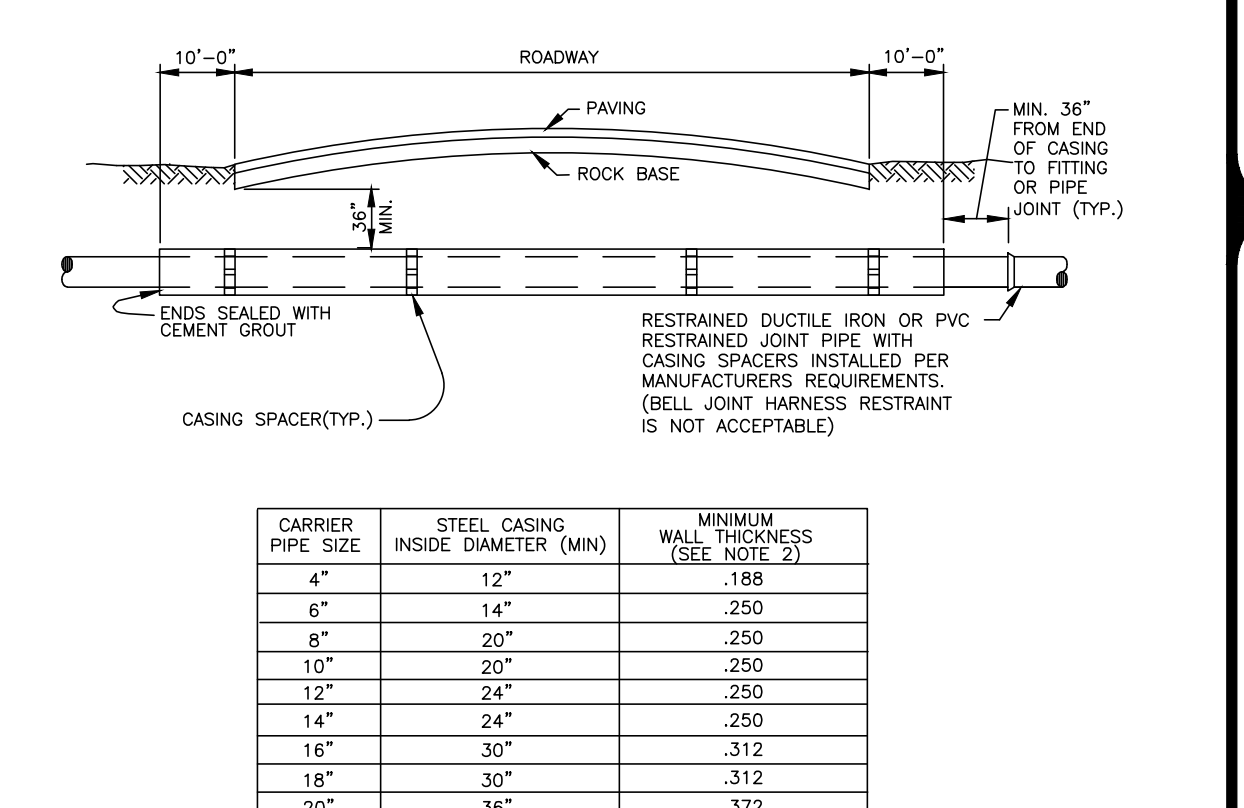

WASTEWATER MAIN CASING INSTALLATION 44S

WASTEWATER #5 STANDARD DETAILS

CONSULTANT: SIMMONS & WHITE
ENGINEERING & PLANNING | CONSULTING & DESIGN | SINCE 1982
2581 Melrose Blvd West • Suite 3 • West Palm Beach, Florida 33407 • (561) 478-7848

IT'S THE LAW!
CALL 48 HOURS BEFORE YOU DIG
1-800-432-4770
SUNSHINE STATE ONE CALL OF FLORIDA, INC.
UTILITIES NOTIFICATION CENTER

JOB NO. 14-091 DRAWING NO. 14091S17

DESIGNED BY: WUD
DRAWN BY: WUD
CHECKED BY: A. GALICKI
APPROVED BY: WUD

Palm Beach County
Water Utilities Department
P.O. Box 16097
West Palm Beach, FL 33416-6097