

©2016 AW ARCHITECTS, INCORPORATED ALL RIGHTS RESERVED. NO PART OF THESE IDEAS, PLANS OR DESIGNS MAY BE REPRODUCED, COPIED OR UTILIZED GRAPHICALLY IN ANY FORM WHATSOEVER WITHOUT THE EXPRESSED WRITTEN CONSENT OF AW ARCHITECTS INCORPORATED AND ITS BOARD OF DIRECTORS.

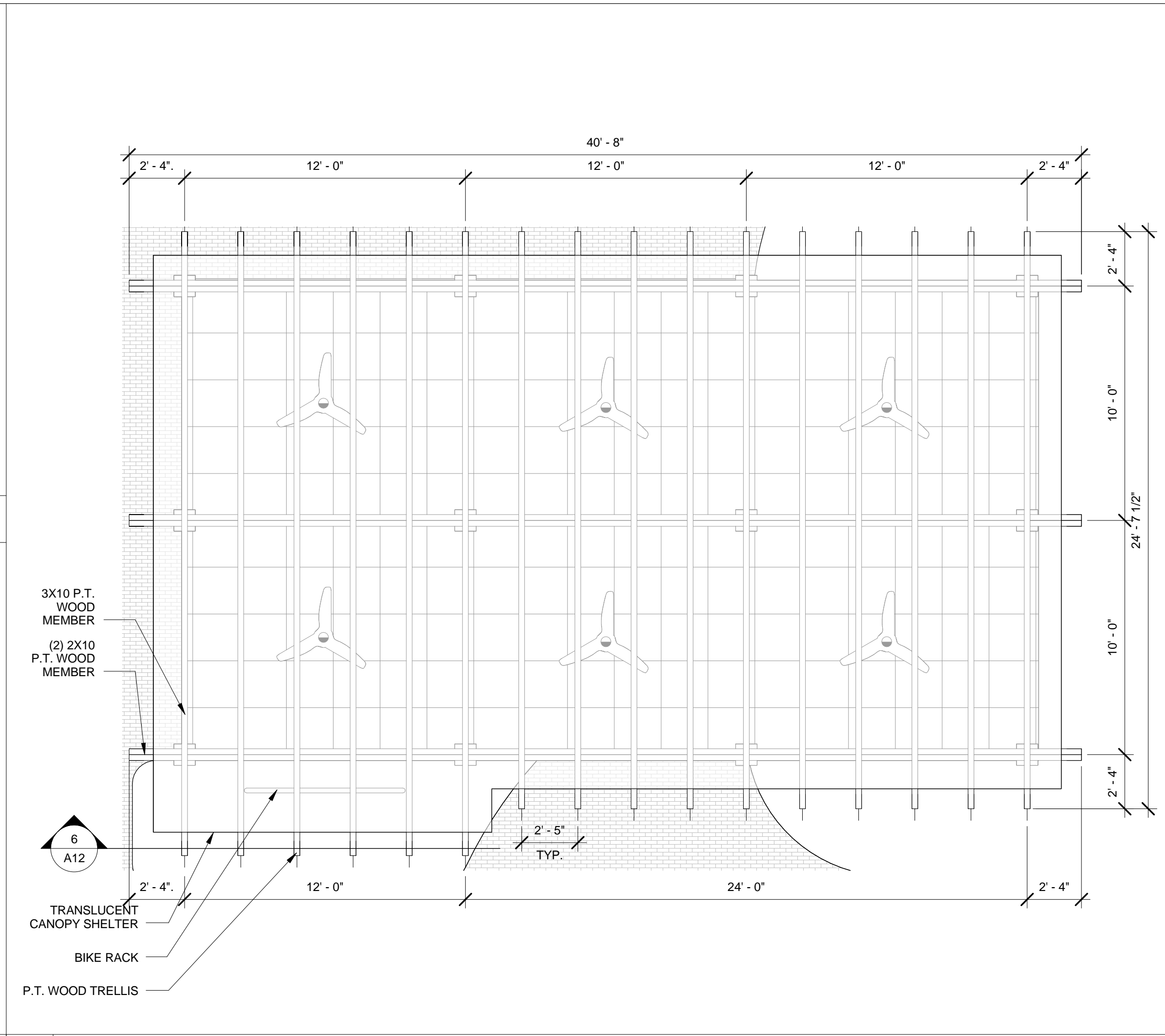

3 TRELLIS ENLARGED PLAN  
SCALE: 1/4" = 1'-0"

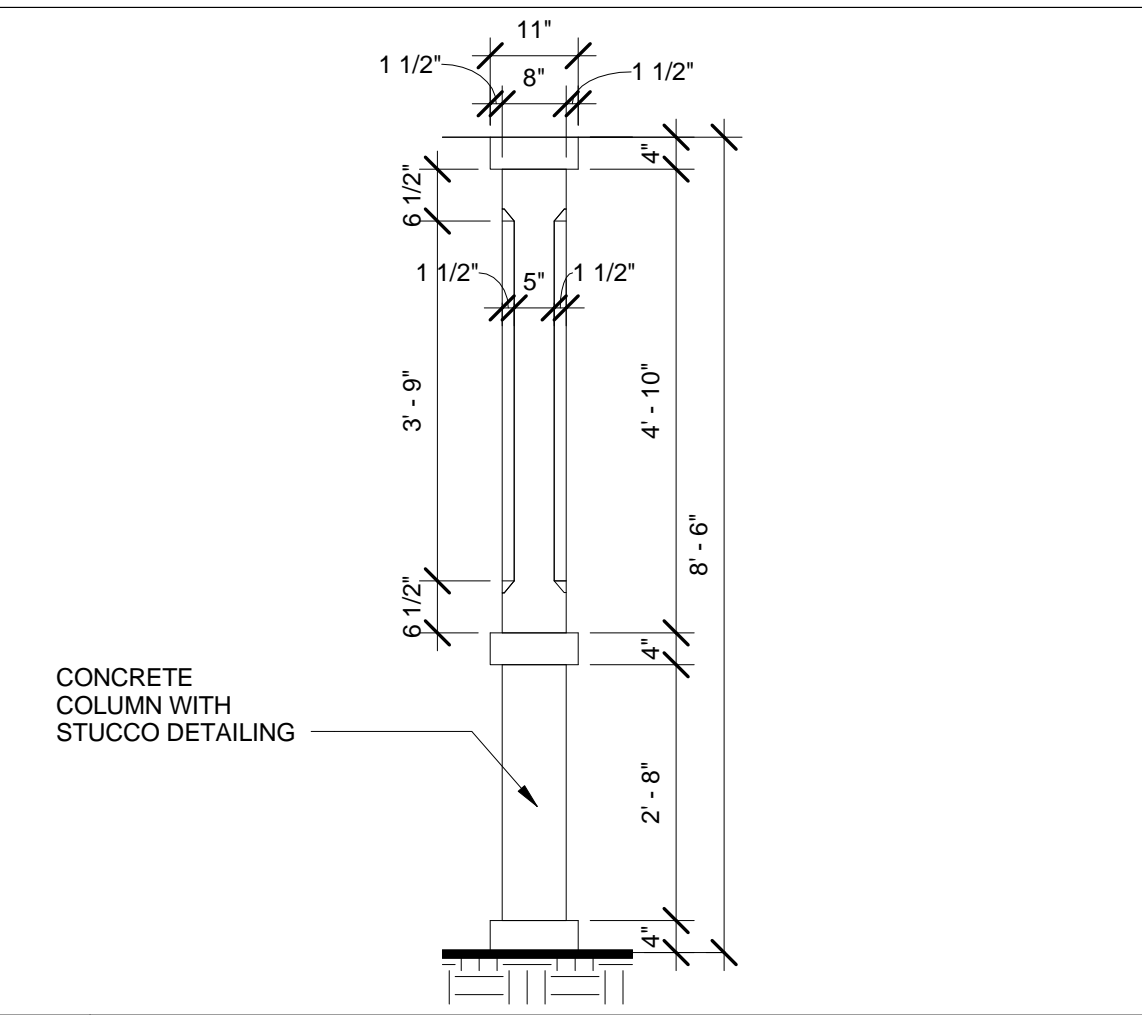

7 TRELLIS COLUMN DETAIL  
SCALE: 1/2" = 1'-0"

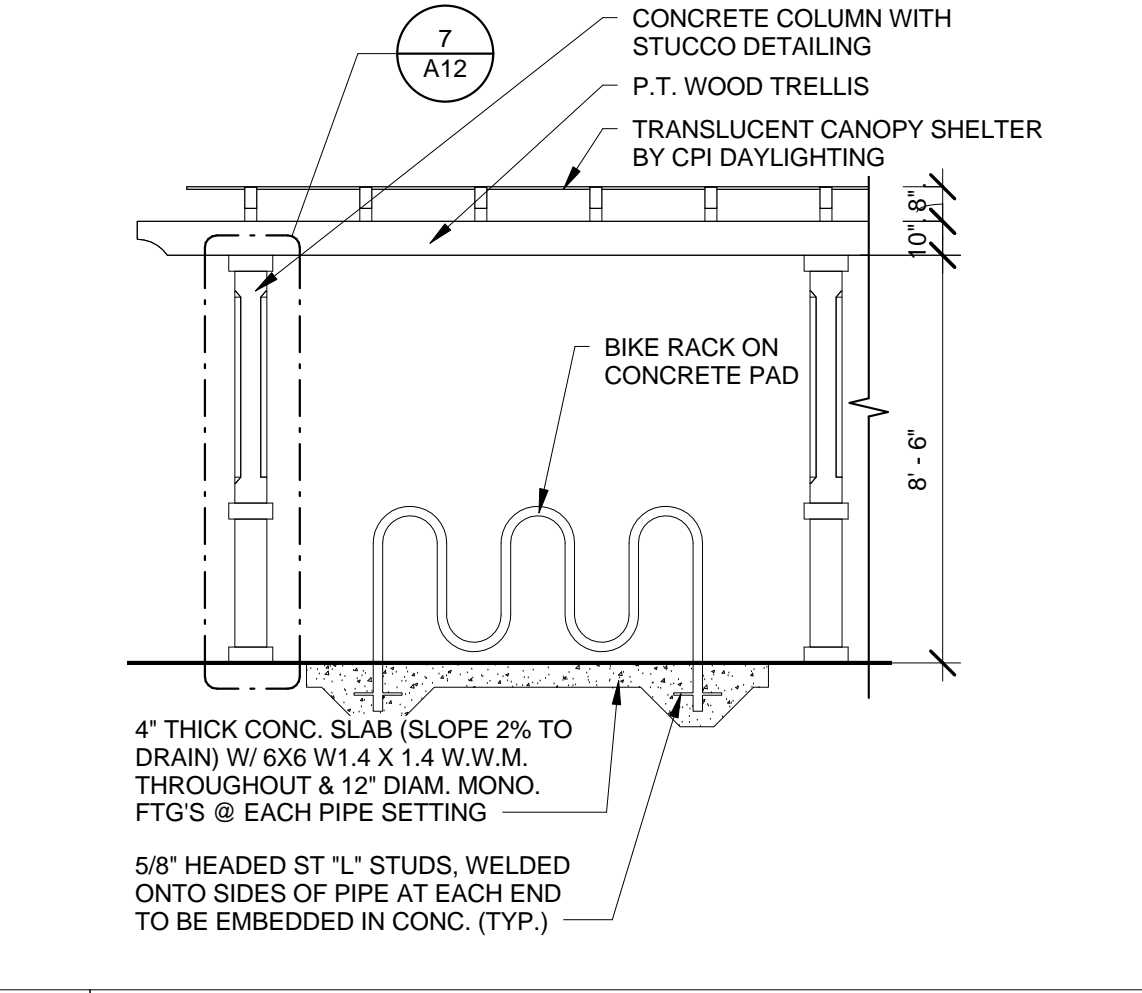

6 PARTIAL TRELLIS ELEVATION  
SCALE: 1/4" = 1'-0"

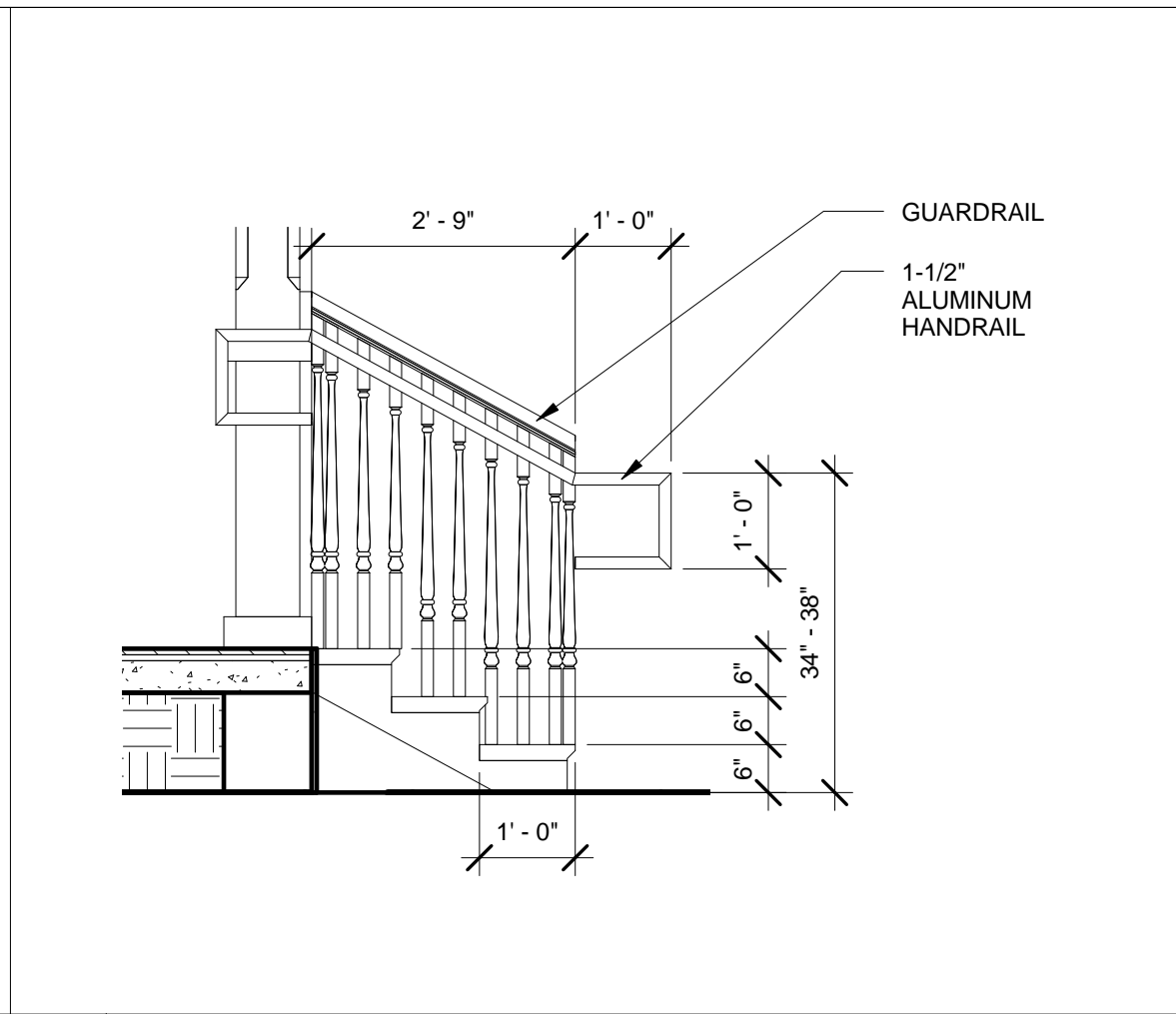

11 WOOD STAIR SECTION DETAIL  
SCALE: 1/2" = 1'-0"

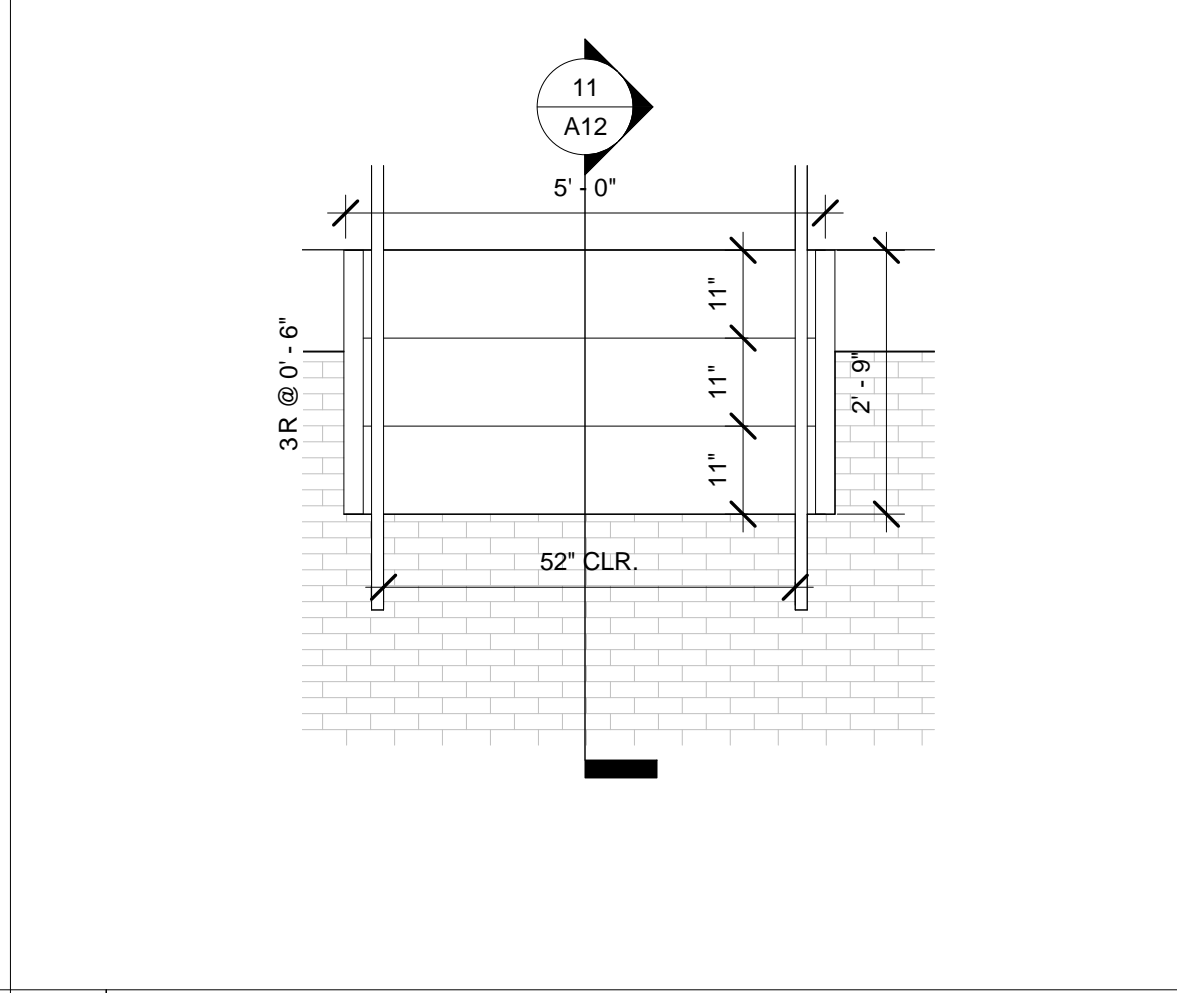

10 WOOD STAIR ENLARGED PLAN  
SCALE: 1/2" = 1'-0"

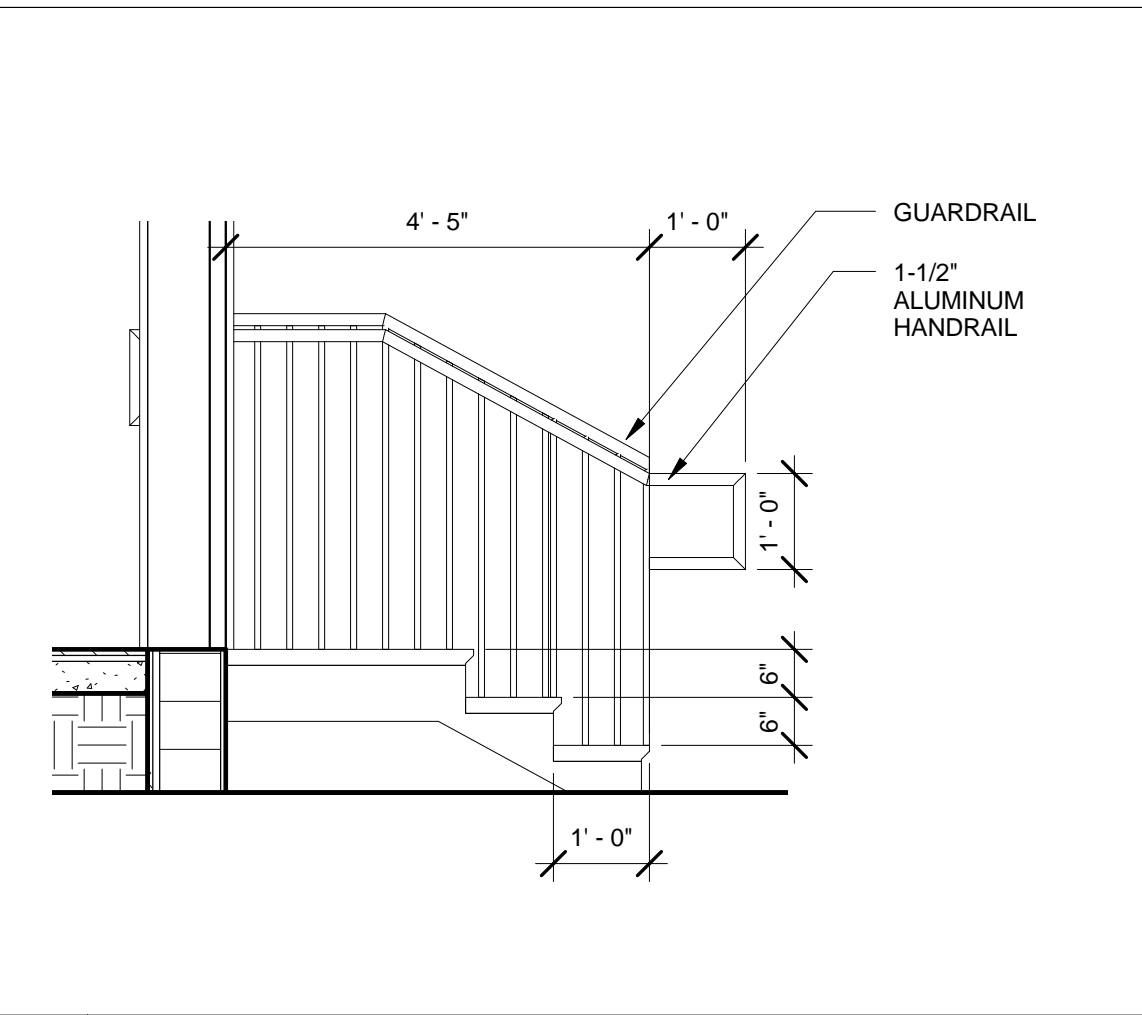

15 ALUMINUM STAIR SECTION DETAIL  
SCALE: 1/2" = 1'-0"

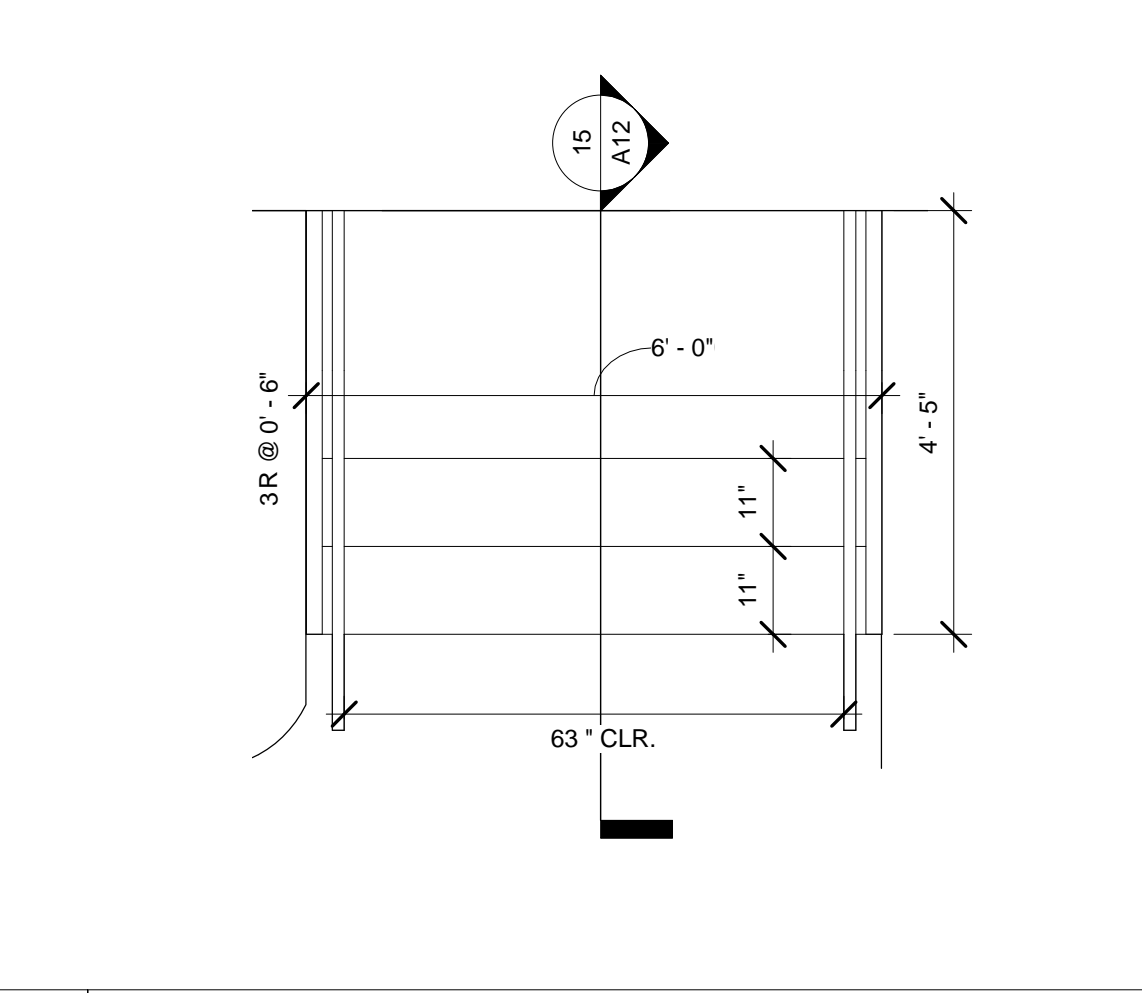

14 ALUMINUM STAIR ENLARGED PLAN  
SCALE: 1/2" = 1'-0"

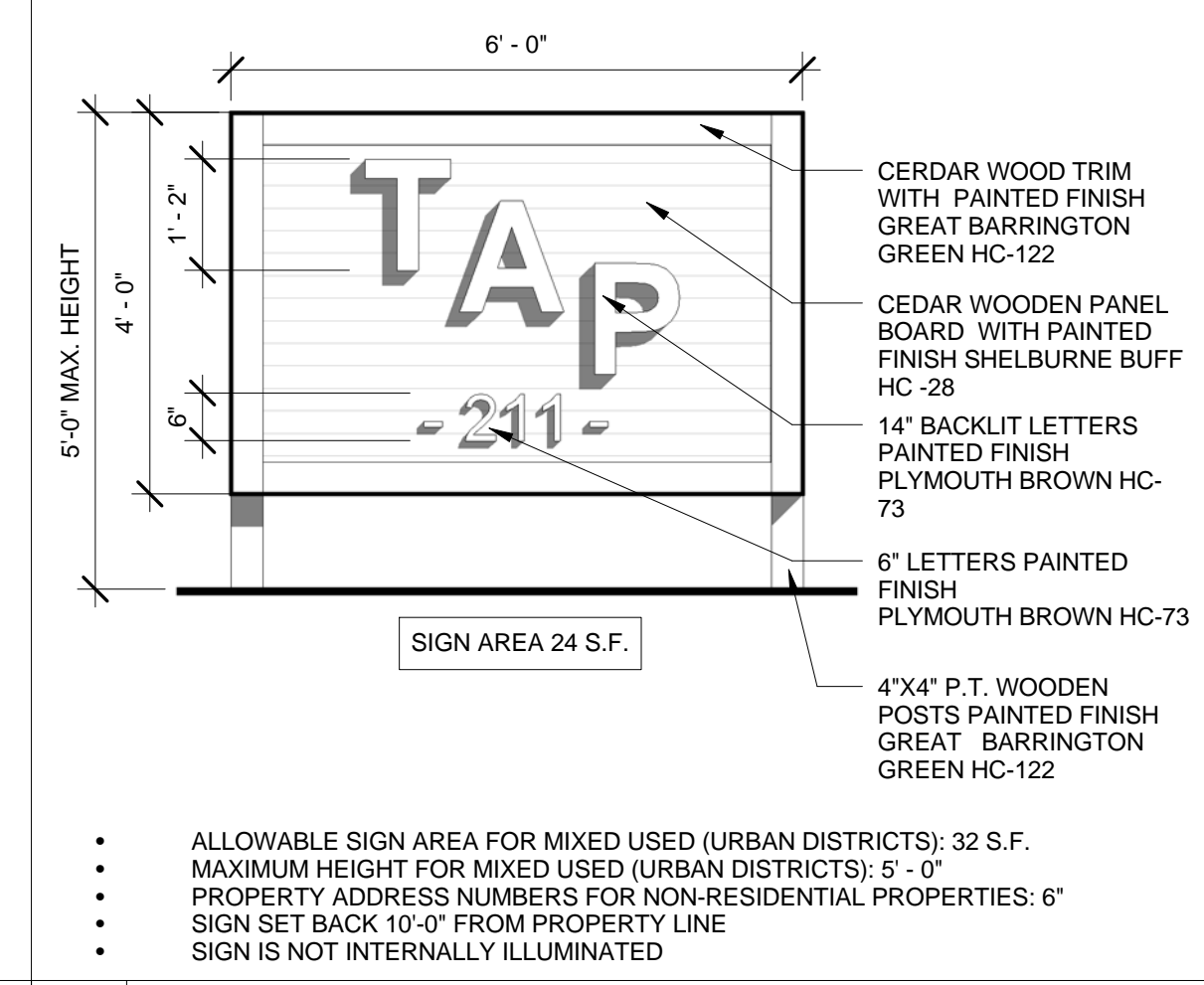

2 BUILDING SIGN ELEVATION  
SCALE: 1/2" = 1'-0"

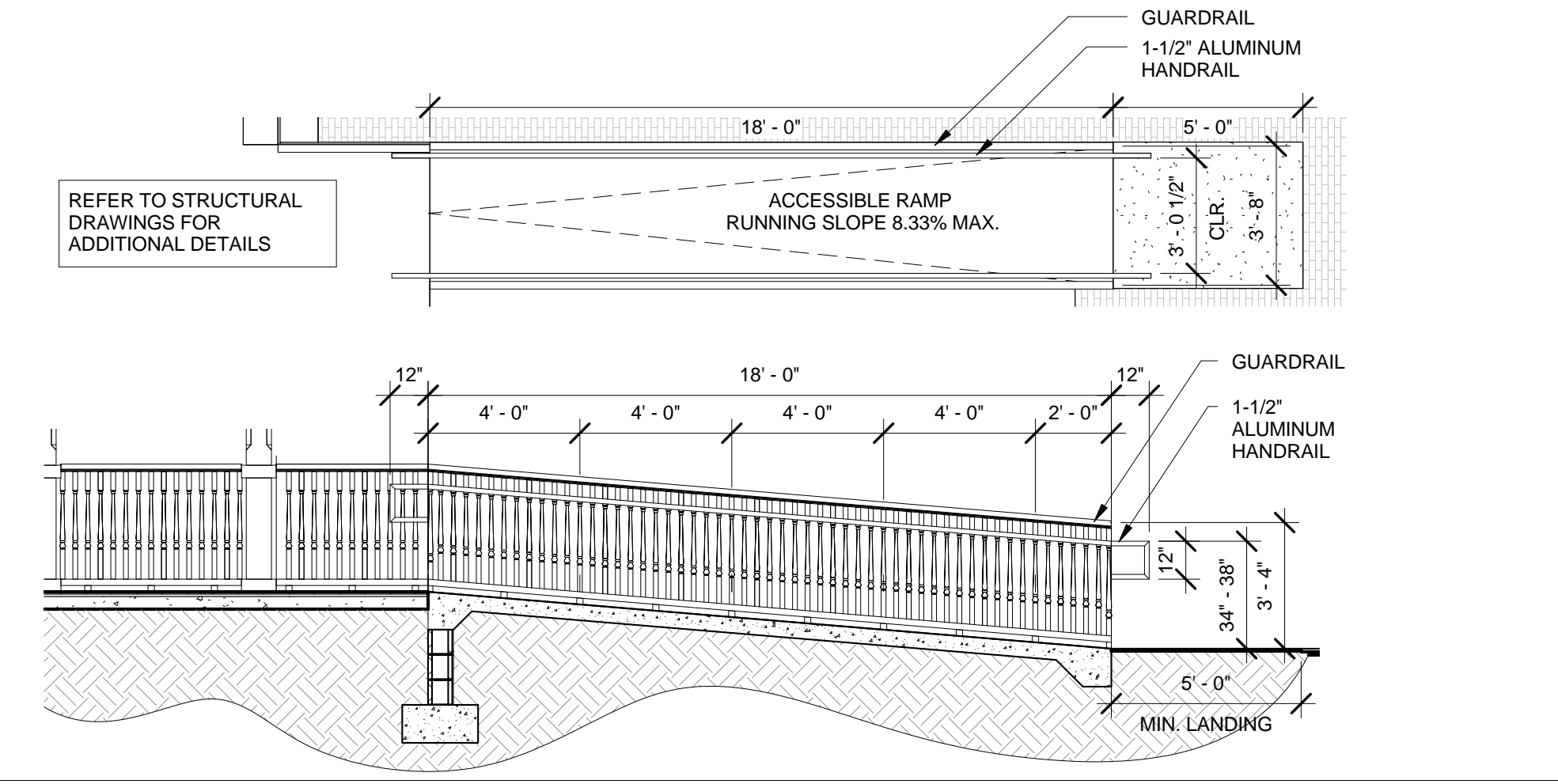

5 RAMP ENLARGED PLAN AND SECTION DETAIL  
SCALE: 1/4" = 1'-0"

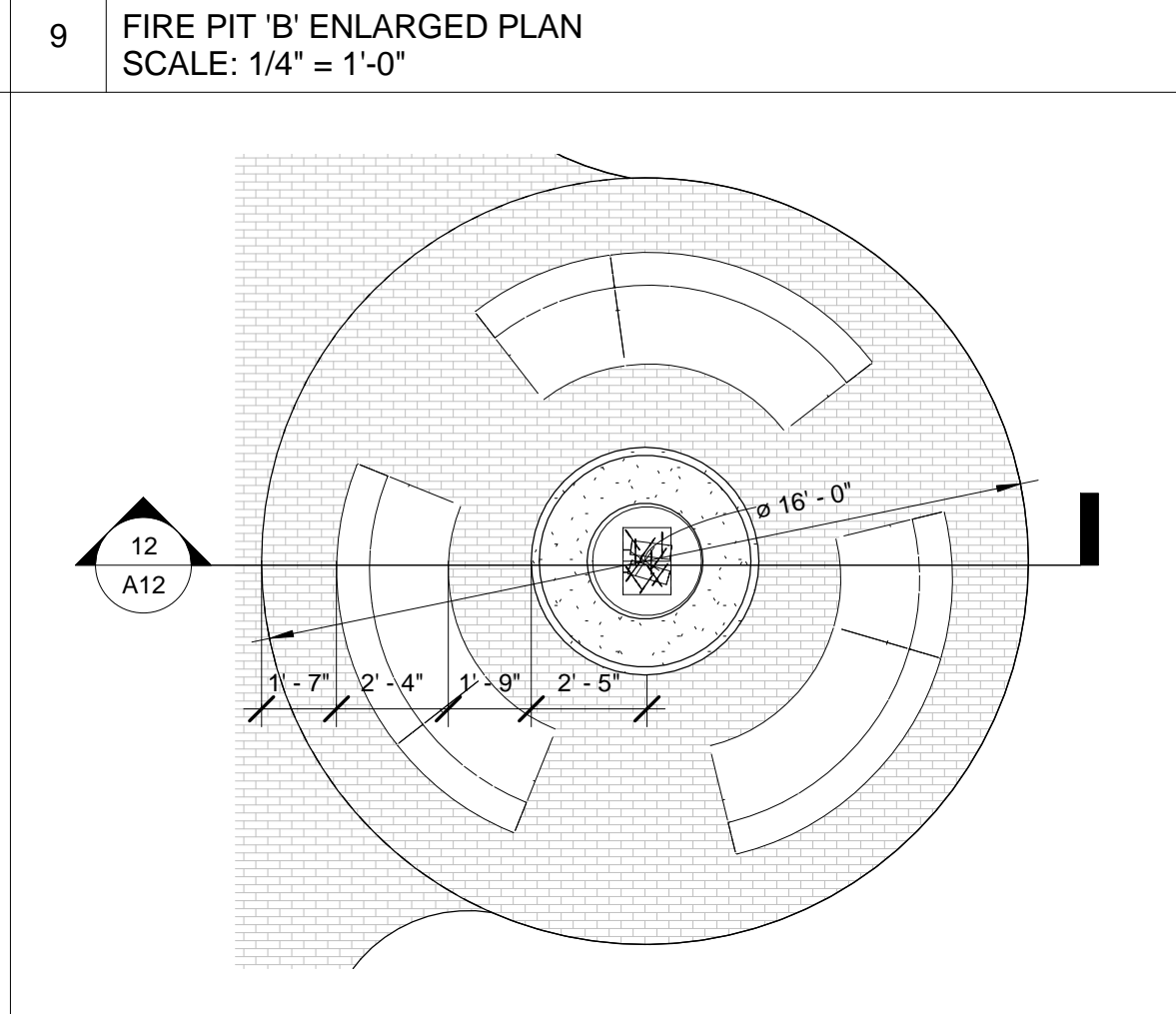

9 FIRE PIT 'B' ENLARGED PLAN  
SCALE: 1/4" = 1'-0"

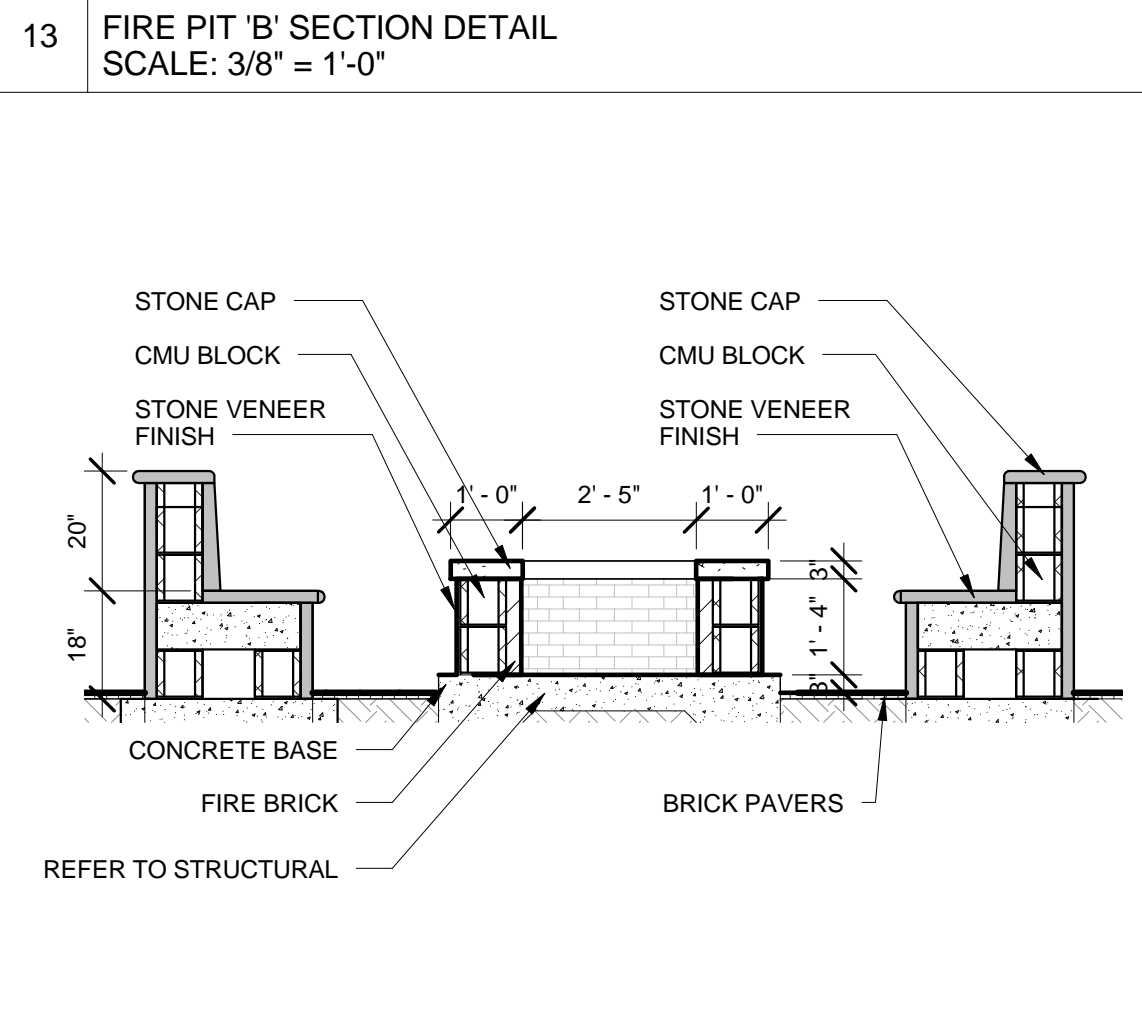

12 FIRE PIT 'A' SECTION DETAIL  
SCALE: 3/8" = 1'-0"

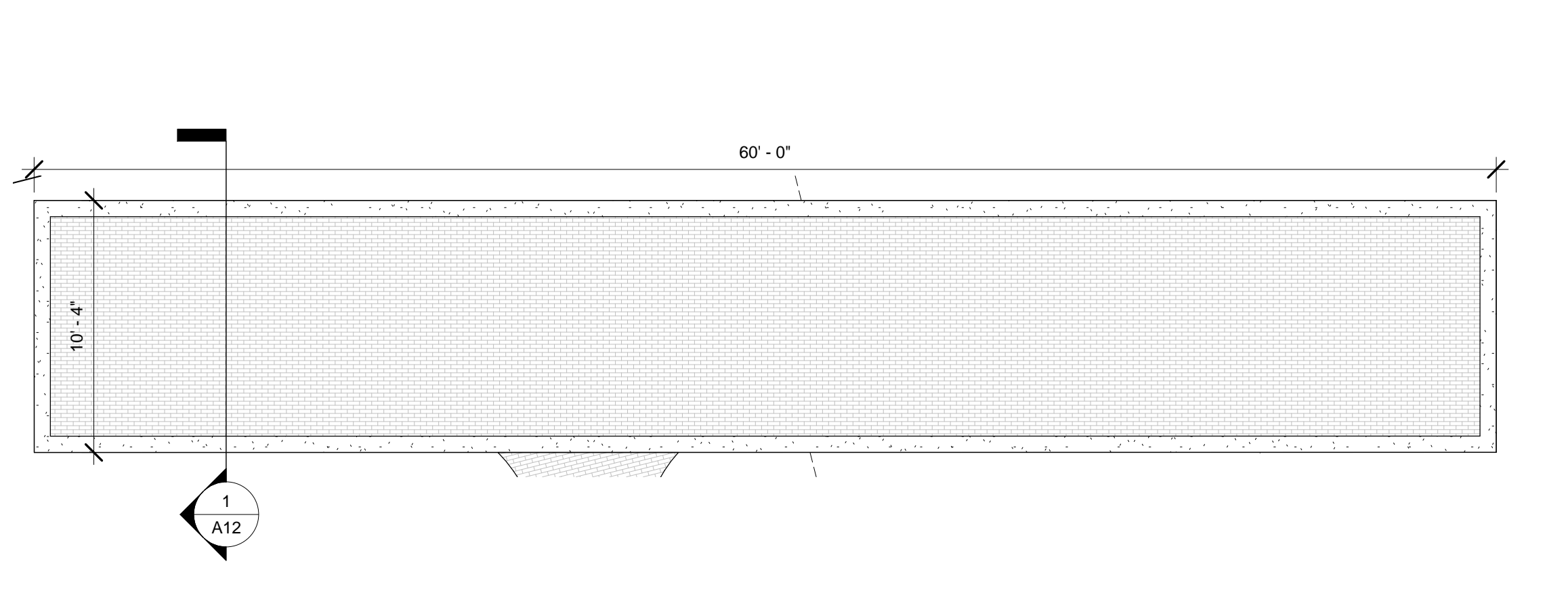

4 BOCCO COURT ENLARGED PLAN  
SCALE: 3/16" = 1'-0"

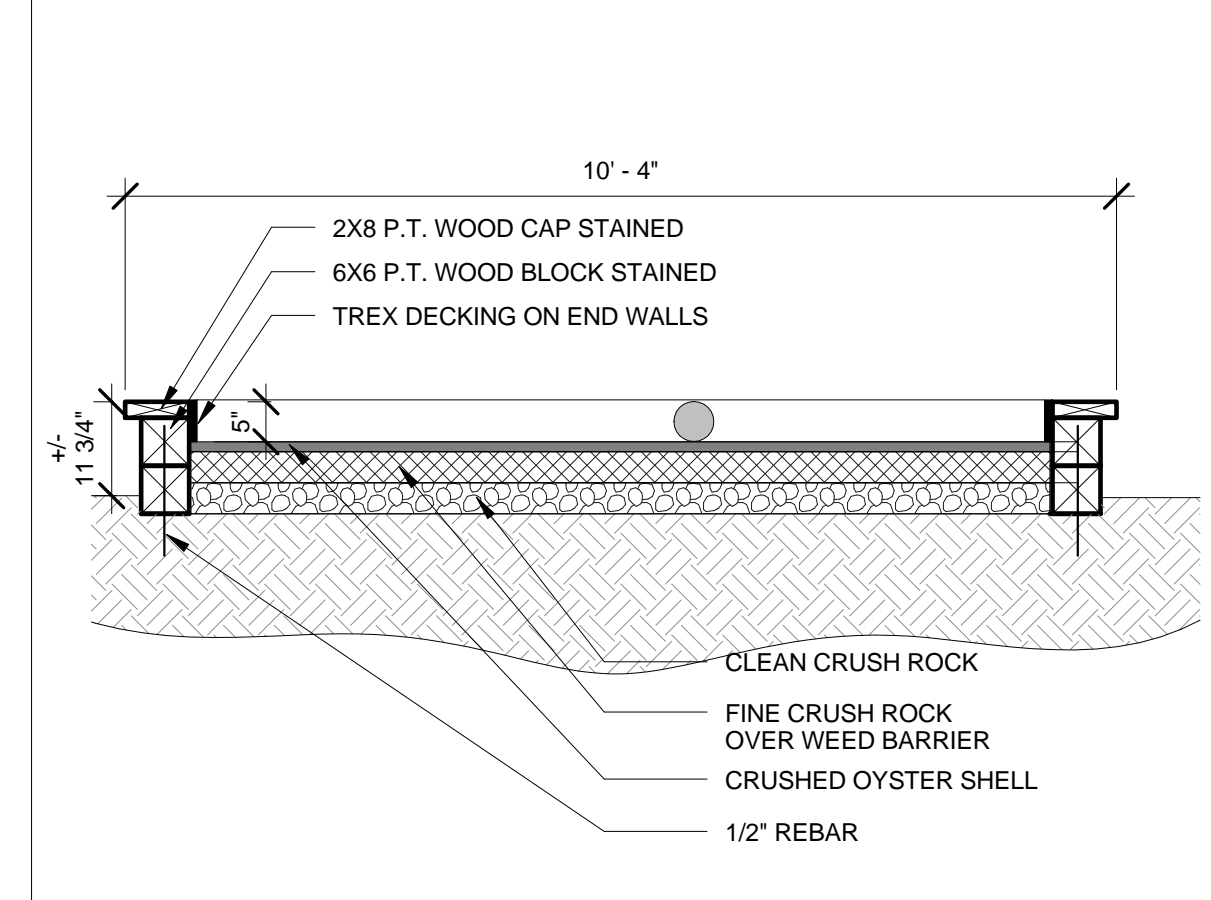

1 BOCCO COURT SECTION  
SCALE: 1/2" = 1'-0"