

DETAIL NO. 1 REFRIGERANT PIPING DETAIL NOT TO SCALE

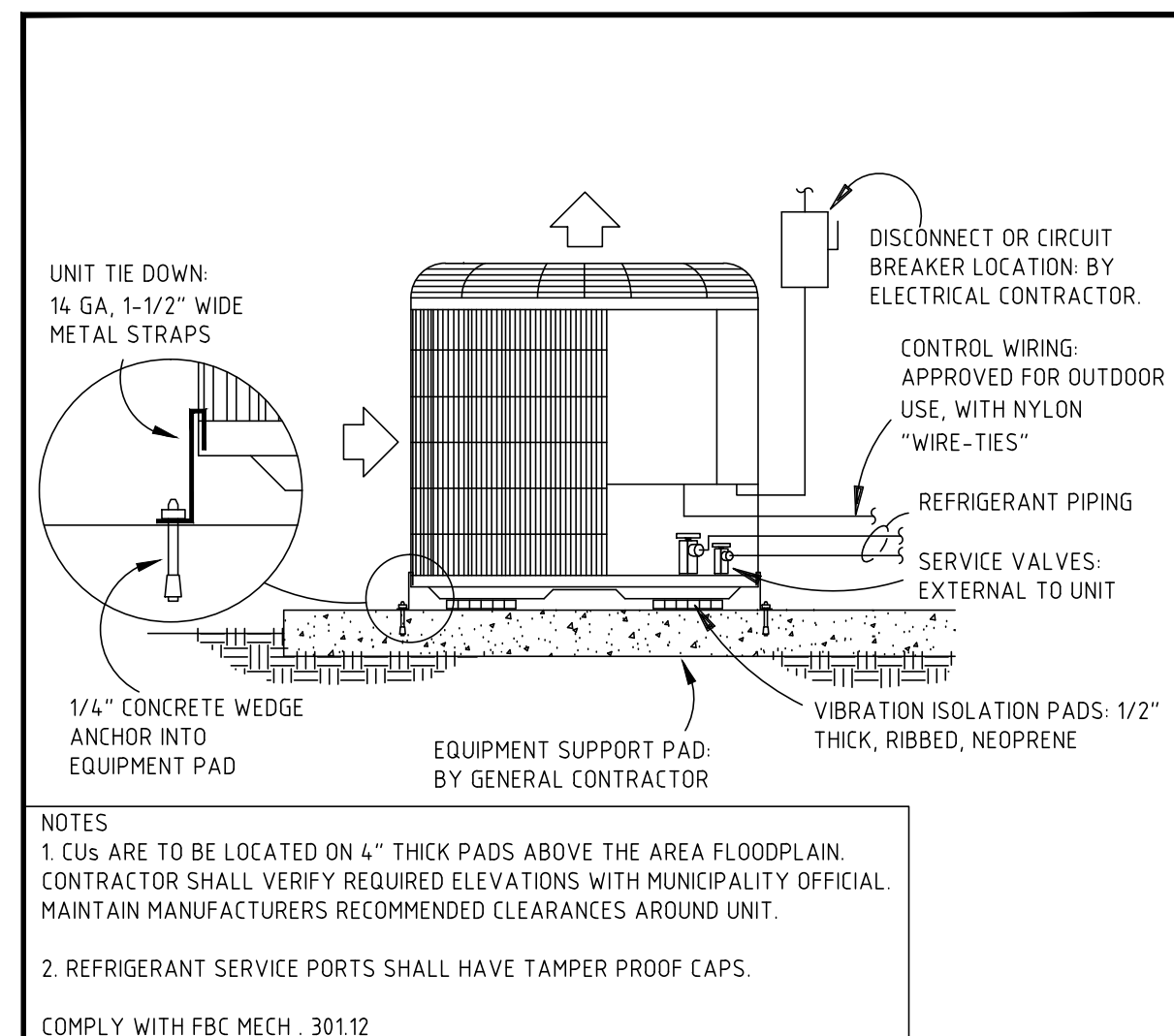

DETAIL NO. 2 CONDENSER MOUNTING DETAIL NOT TO SCALE

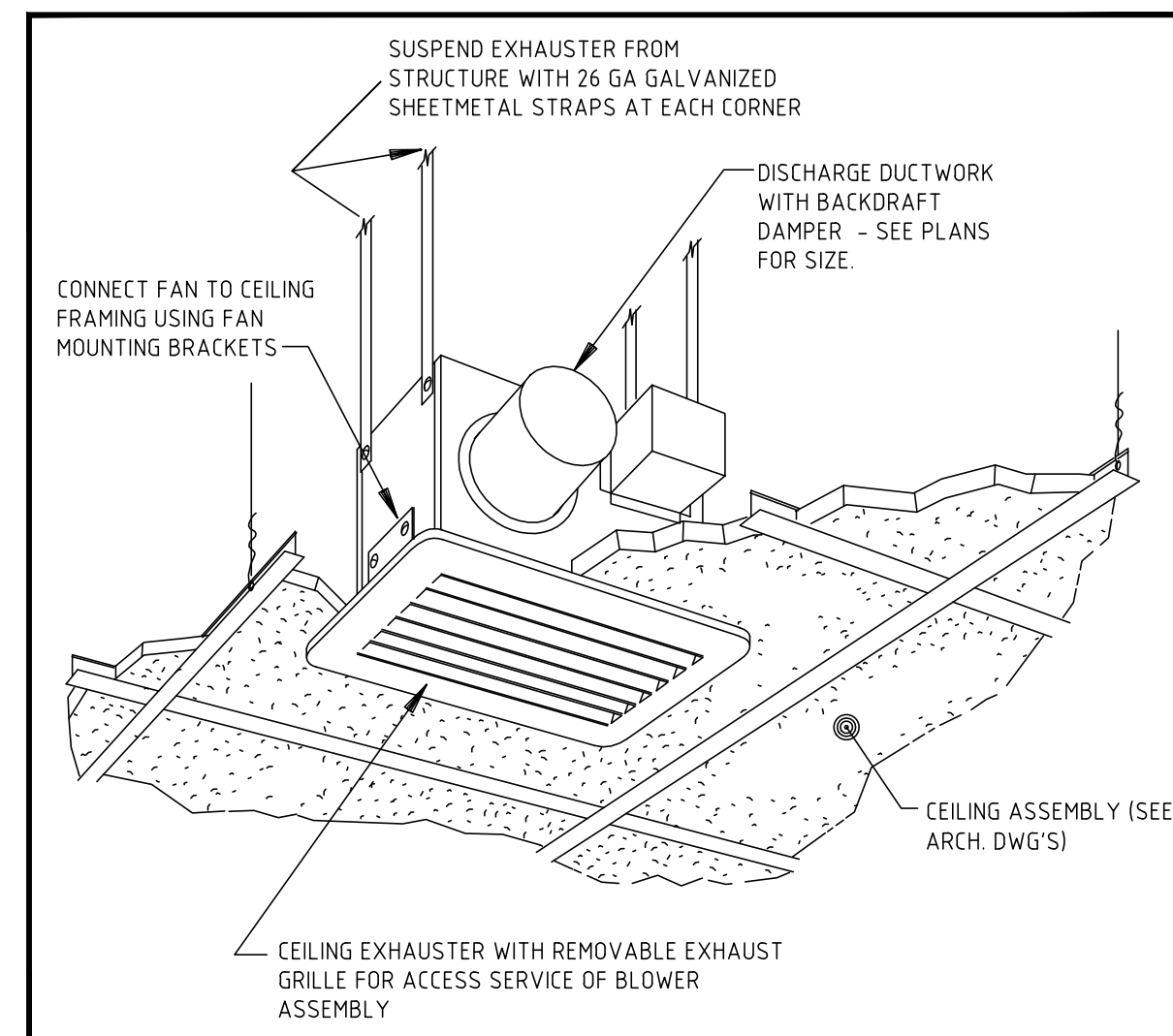

DETAIL NO. 3 CEILING MOUNTED FAN DETAIL NOT TO SCALE

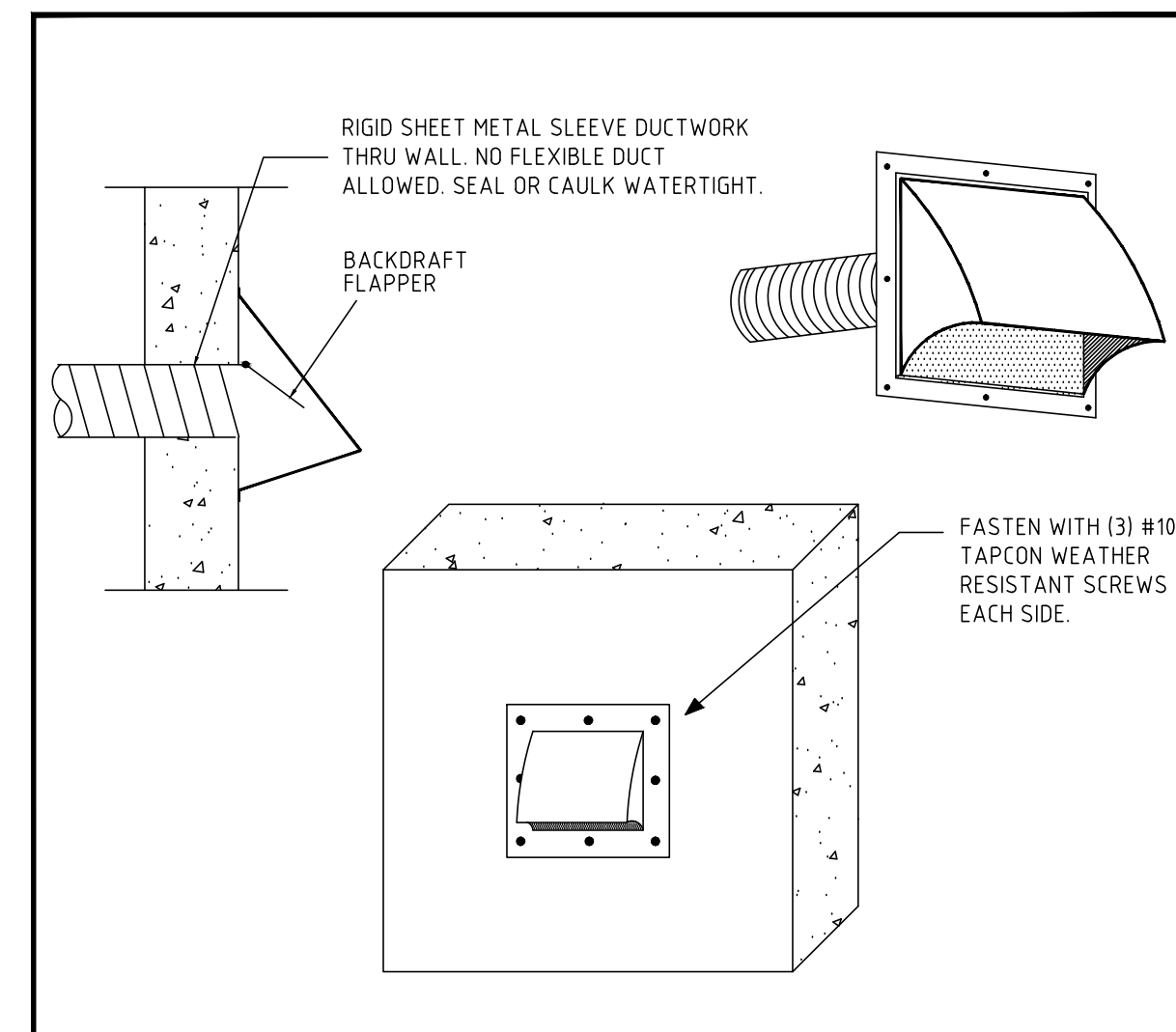

DETAIL NO. 4 WALL CAP DETAIL NOT TO SCALE

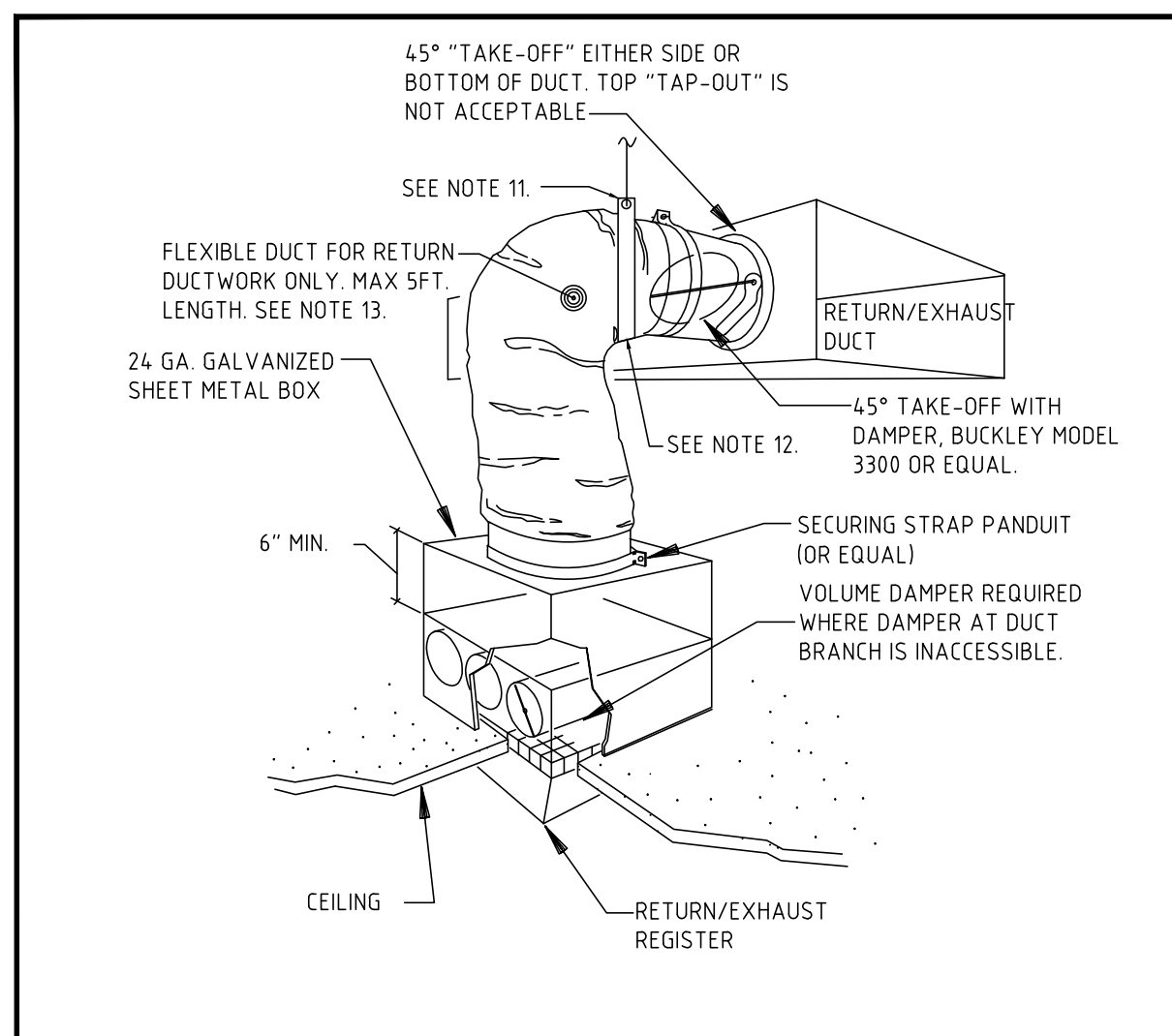

DETAIL NO. 5 DUCTWORK CONNECTION TO RETURN/EXHAUST GRILLE (FLEX DUCT) DETAIL NOT TO SCALE

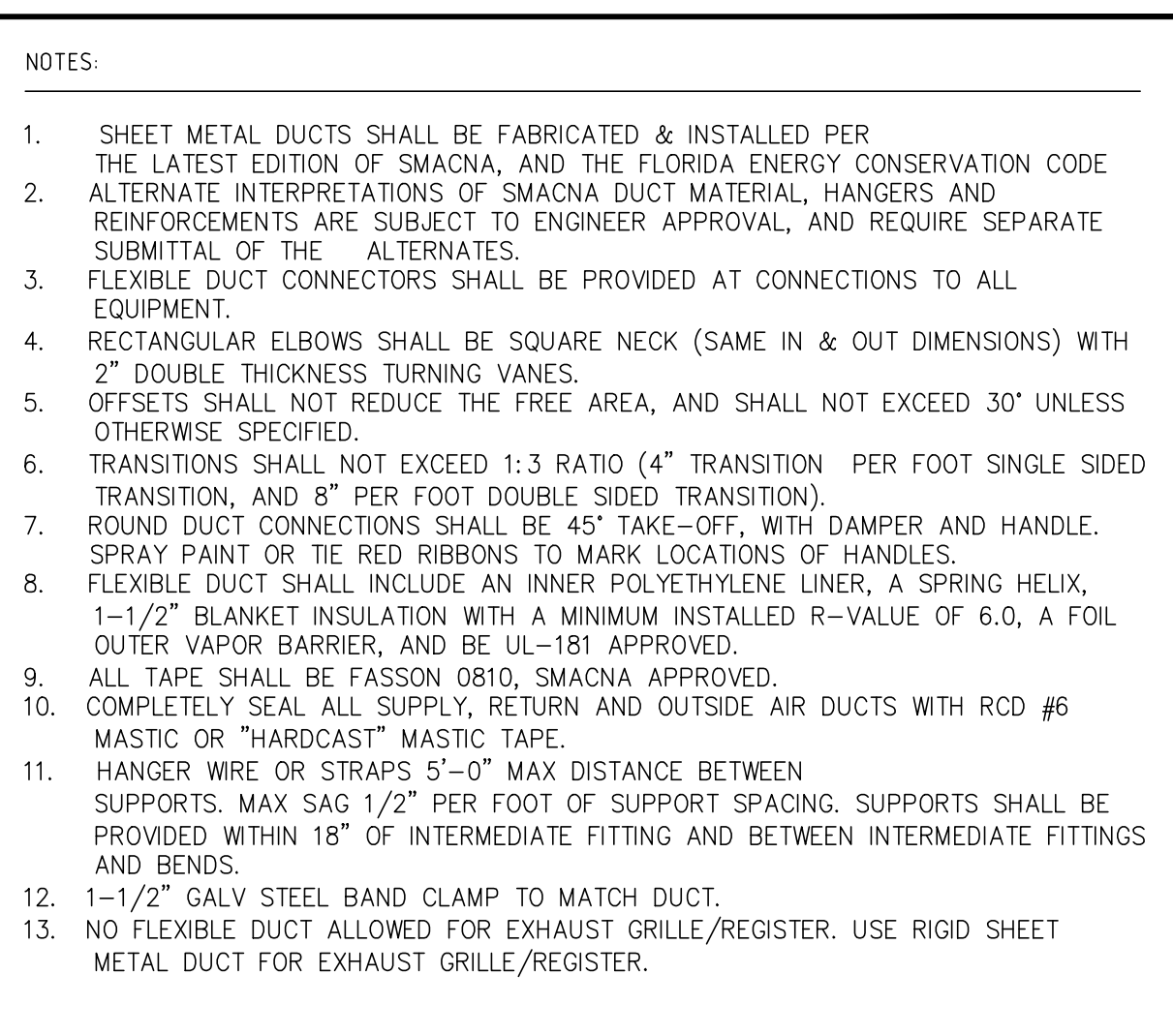

DETAIL NO. 6 DUCTWORK CONNECTION TO SUPPLY DIFFUSER (FLEX DUCT) DETAIL NOT TO SCALE

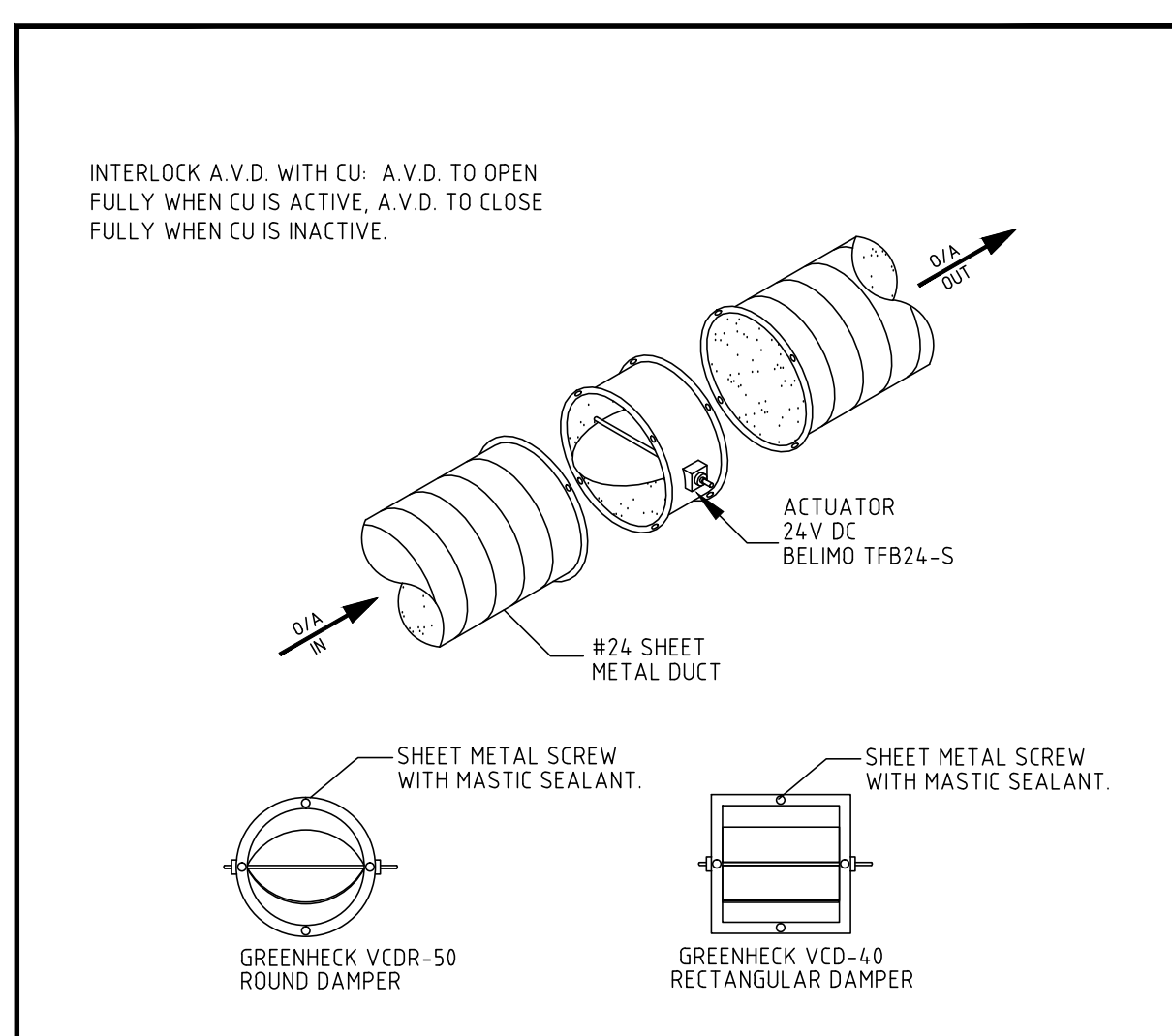

DETAIL NO. 7 AUTOMATIC VOLUME DAMPER (A.V.D) DETAIL NOT TO SCALE

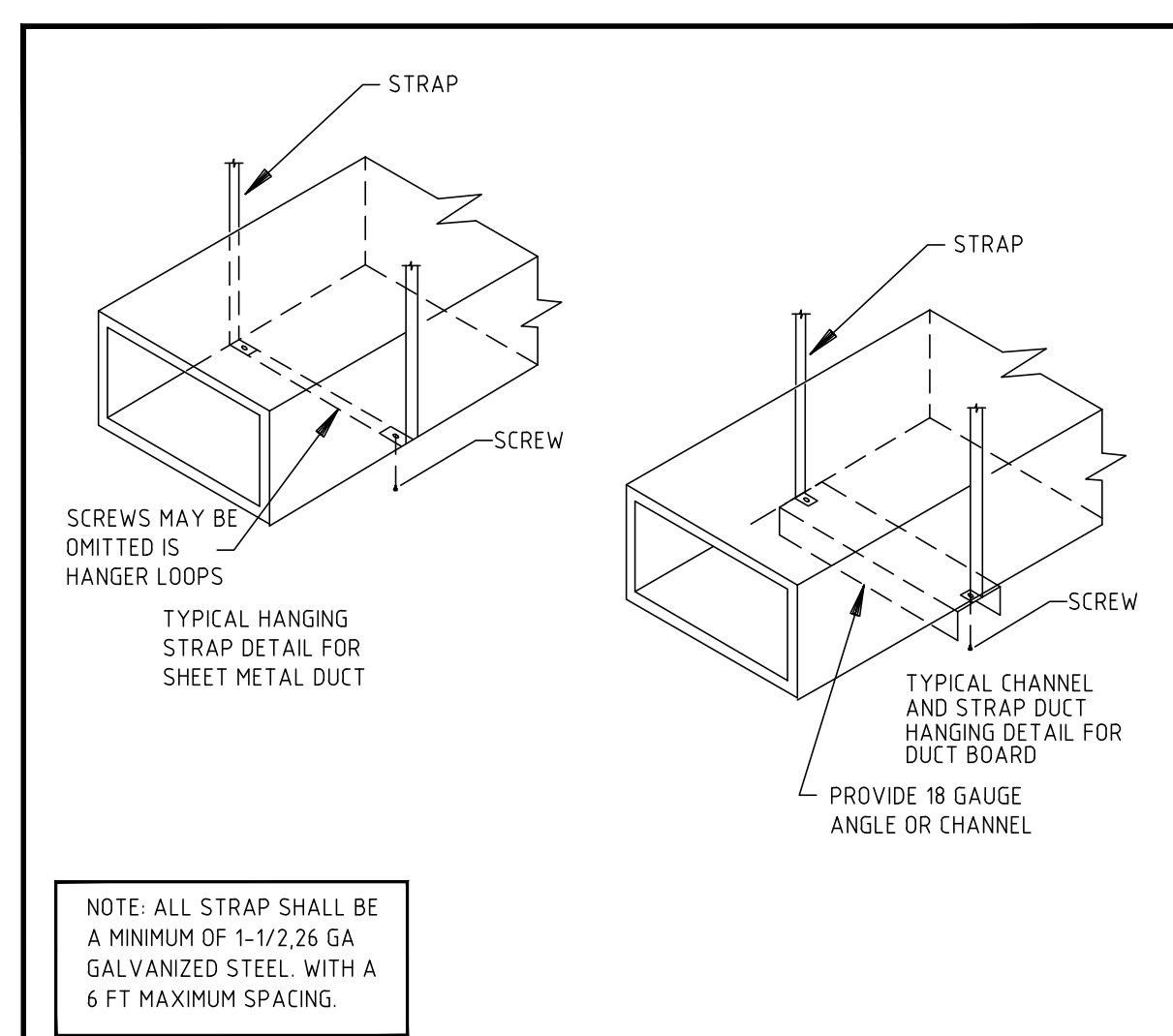

DETAIL NO. 8 METHODS OF HANGING RIGID DUCT DETAIL NOT TO SCALE

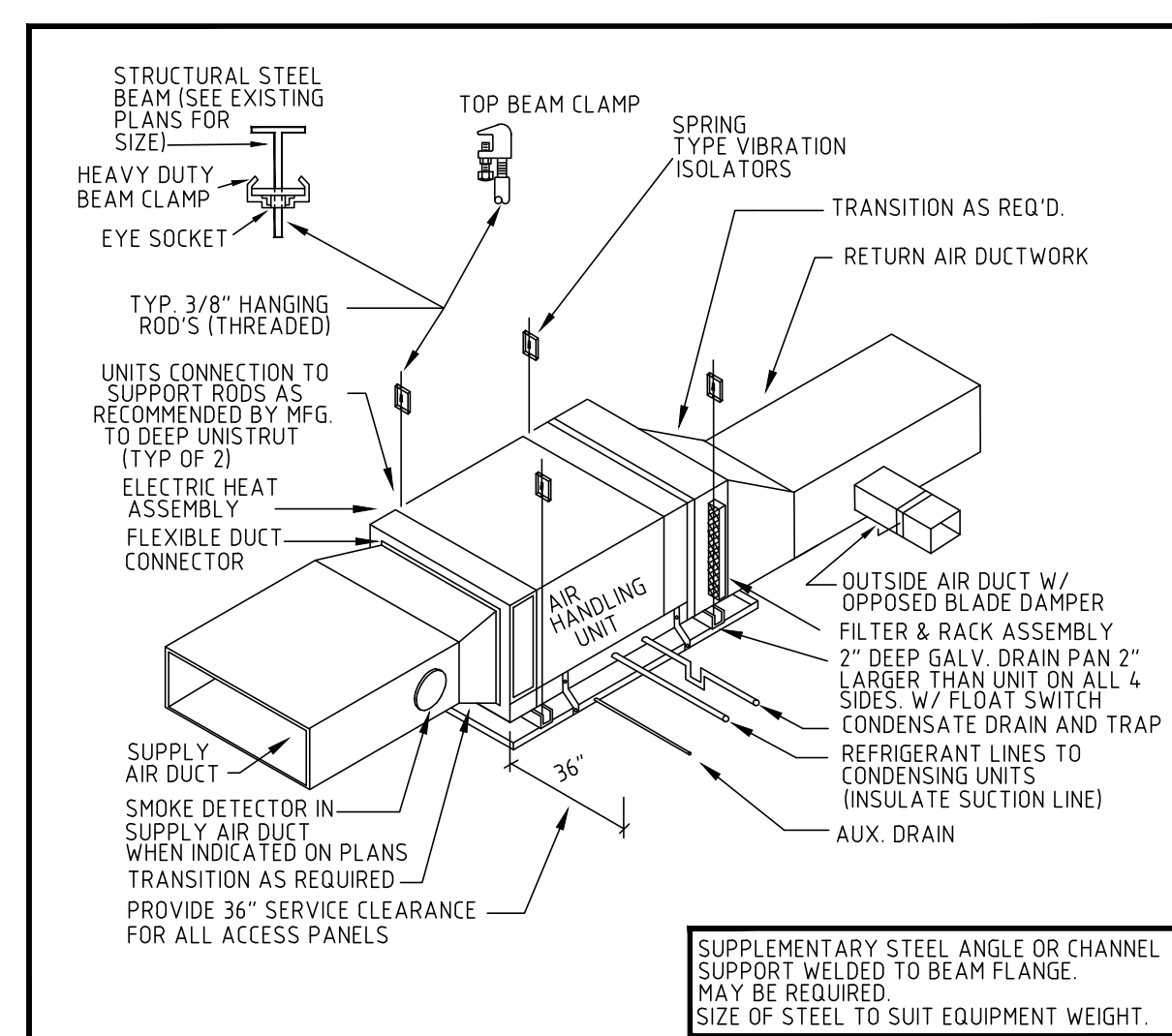

DETAIL NO. 9 AIR HANDLER DETAIL NOT TO SCALE

PROGRESS OR CHECK SETS, BY THEIR NATURE, MAY BE INCOMPLETE AND ARE NOT TO BE USED FOR BIDDING OR CONSTRUCTION. CONTRACTOR RECOGNIZES HIS SOLE RESPONSIBILITY TO INCLUDE ALL CONTINGENCIES FOR DESIGN AND INSTALLATION TO MEET THE PROJECT REQUIREMENTS IN ANY PRICING EXERCISE.

PRIOR TO SUBMITTING THE BID, THE CONTRACTOR SHALL FIELD VERIFY ALL EXISTING CONDITIONS AND INFORM THE ARCHITECT AND THE ENGINEER OF ANY DISCREPANCY BETWEEN THESE DOCUMENTS AND THE EXISTING CONDITIONS AND SHALL INCLUDE IN THE BID TO CORRECT THE SAME AS DIRECTED. THE ENGINEER AND THE ARCHITECT, ARE NOT RESPONSIBLE FOR ANY ADDITIONAL COSTS RESULTING FROM VERIFIABLE EXISTING CONDITIONS DISCOVERED AFTER CONTRACT HAS BEEN AWARDED. NO CHANGES SHALL BE MADE TO THESE PLANS WITHOUT PRIOR APPROVAL FROM THE ENGINEER OF RECORD. ALL CHANGES SHALL BE SUBMITTED FOR REVIEW PRIOR TO INSTALLATION. NOT FOR BID UNTIL PERMIT HAS BEEN ISSUED.

CHECK SET: 02/22/16



700 WEST HILLSBORO BLVD. - BLDG. #1, SUITE 204
DEERFIELD BEACH, FLORIDA 33441
TEL: (561) 391-9292 FAX: (561) 391-9998
CERTIFICATE OF AUTHORIZATION NO. 28107
URSULA IARRATE, P.E. LICENSE #75122
STEPHEN F. ROLLIN, P.E. LICENSE #36428
DONALD H. AUSTIN, JR., P.E. LICENSE #60651
JASON BARBER, P.E. LICENSE #73050
E-MAIL: INFO@FAECNBUILDING.COM
DESIGNED BY: KW/AS PM: AN P/N 16014

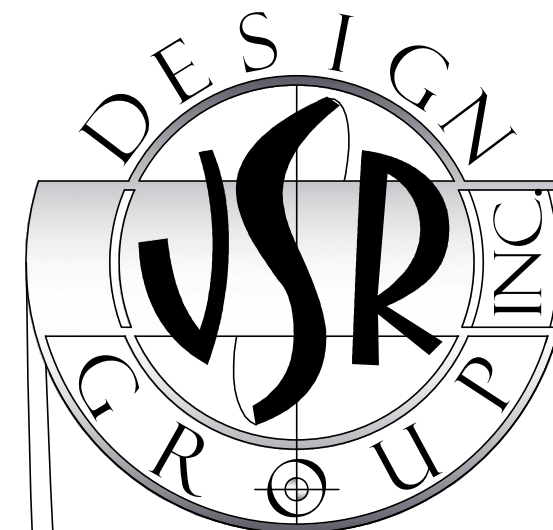

LEVEL 2 ALTERATION
TENANT BUILD-OUT FOR:
SF PROCESSING
1315 N. FEDERAL HWY. 2ND.FLOOR
BOYNTON BEACH, FL. 33435

JOHN SHERMAN REED
ARCHITECT
FL LICENSE# AR9571

JSR DESIGN GROUP INC.
970 SW 4TH STREET
BOCA RATON, FL 33486
FL LICENSE# AR9571
TEL: 561-362-7203
FAX: 561-362-7204

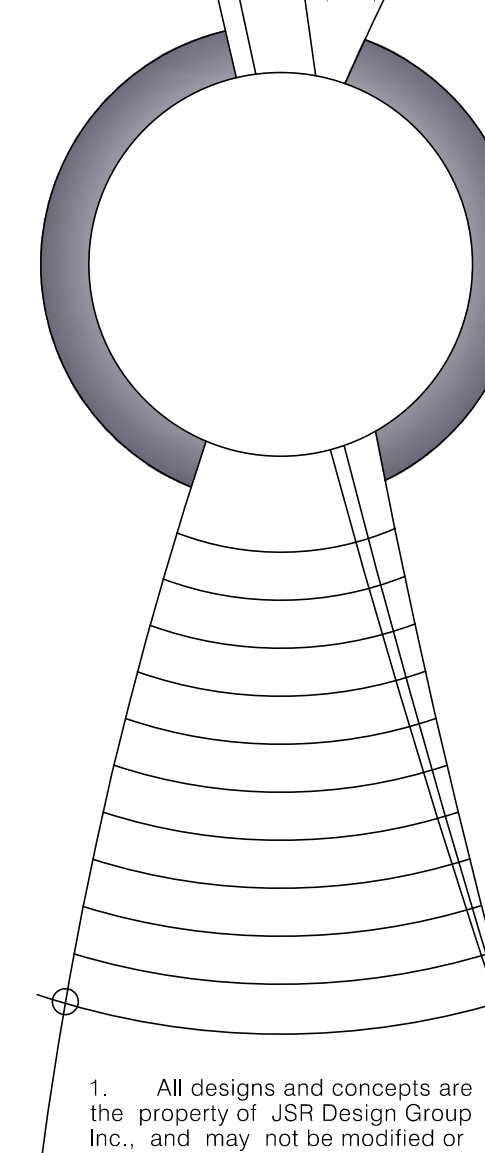

- All designs and concepts are the property of JSR Design Group Inc., and may not be modified or copied without written permission by the architect.
- Contractor to verify all written dimensions (Not scaled) & notify architect of any discrepancies or omissions. Construction shall not proceed until said discrepancies or omissions have been resolved by architect.
- Contractor to verify and approve all shop drawings and dimensions before having drawings reviewed and accepted by the architect prior to construction.

16014

M5.1