

BASKETBALL SURFACE DETAILS:

- A. 0.09 GALLONS PER SQUARE YARD PER COAT (2 COATS) OF ACRYLIC RESURFACER BY SPORTMASTER SPORT SURFACES OR APPROVED EQUAL.
- B. 0.08 GALLONS PER SQUARE YARD PER COAT (2 COATS) OF ACRYLIC COLOR CONCENTRATE (GREEN) BY SPORTMASTER SPORT SURFACES OR APPROVED EQUAL.
- C. 500 LINEAL FEET OF 2-INCH WHITE LINE PAINT PER GALLON (1 COAT) BY SPORTMASTER SPORT SURFACES OR APPROVED EQUAL.

BASKETBALL COURT CROSS SECTION

SCALE: NONE

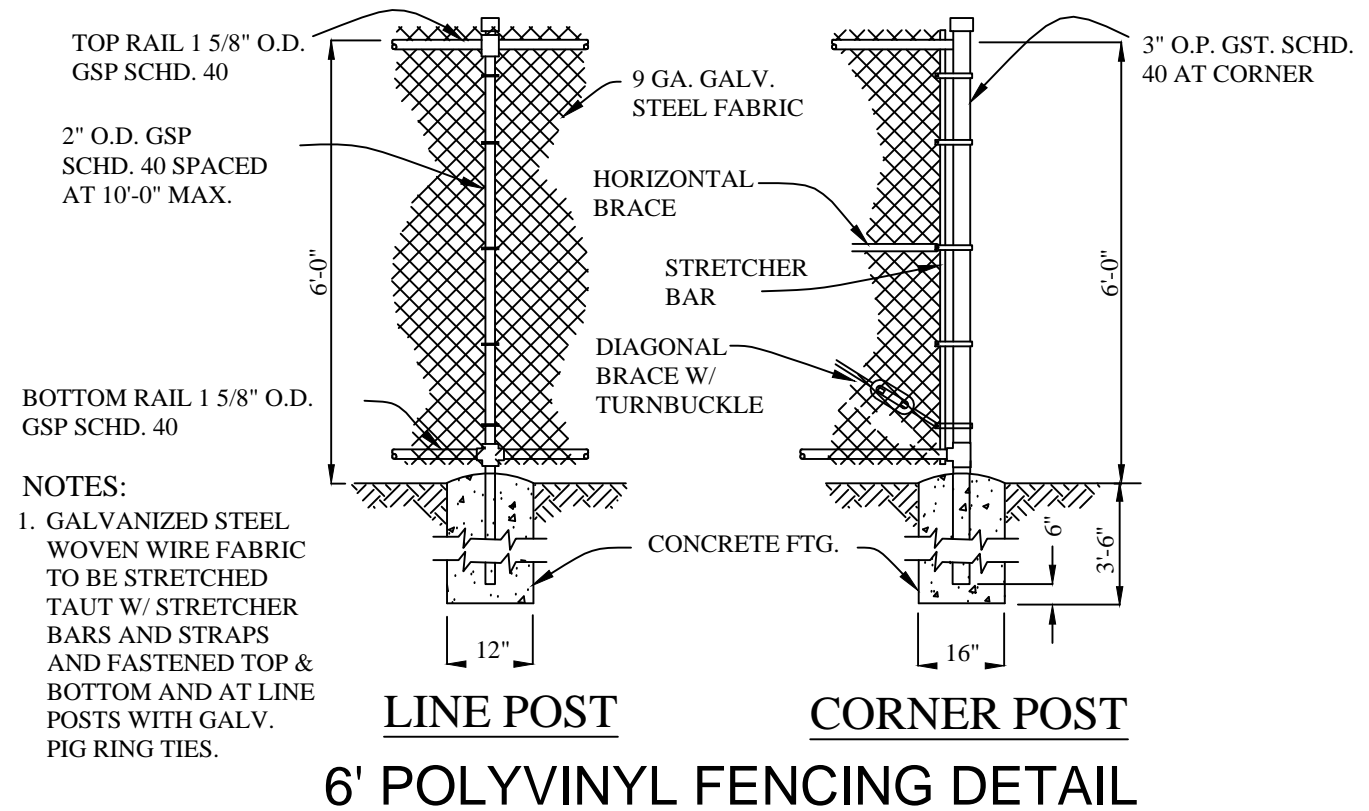

NOTES:
 1. GALVANIZED STEEL WOVEN WIRE FABRIC TO BE STRETCHED TAUT W/ STRETCHER BARS AND STRAPS AND FASTENED TOP & BOTTOM AND AT LINE POSTS WITH GALV. PIG RING TIES.

SCALE: NONE

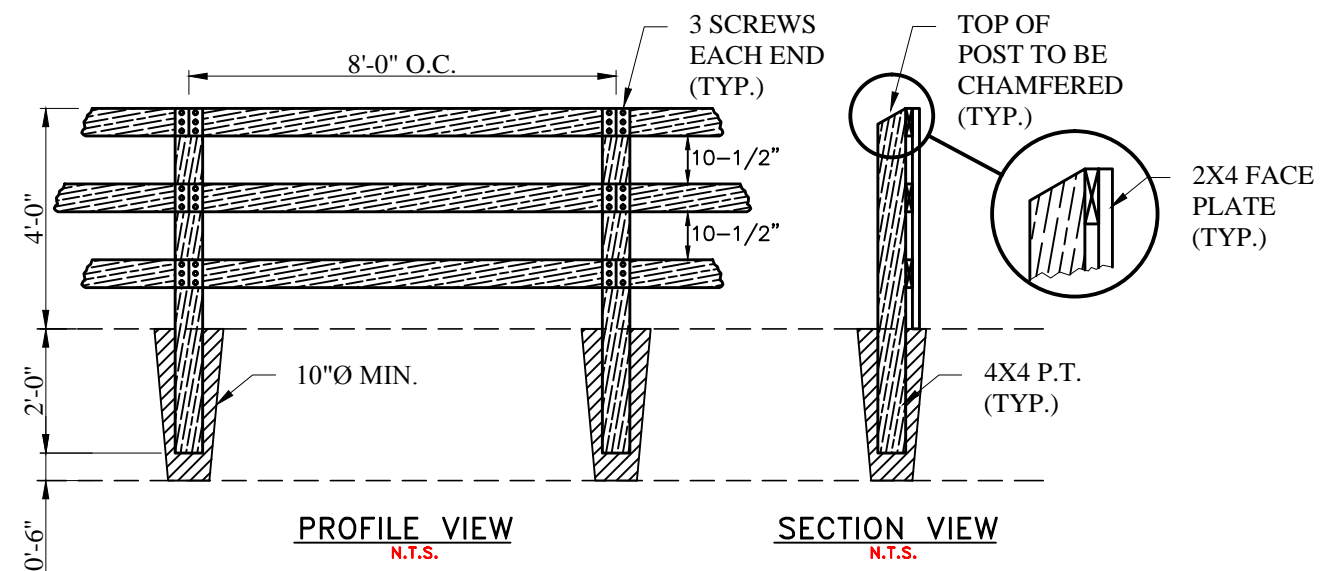

- NOTES:
- 1. ALL WOOD SHALL BE PRESSURE TREATED
 - 2. ALL FACE PLATES & FENCE RAILS SHALL FACE THE 'STREET SIDE' OF THE POSTS.
 - 3. FASTENERS TO BE 3" GALVANIZED WOOD SCREWS.
 - 4. WOODEN POST TO BE DIRECT BURIED IN GROUND.

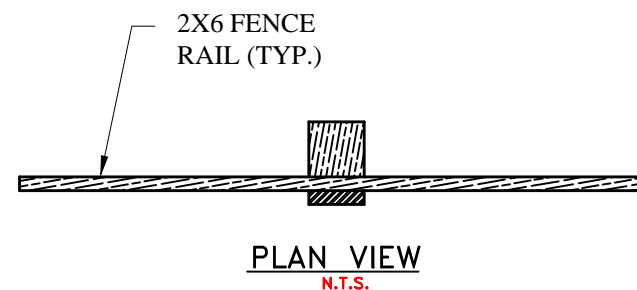

3 RAIL WOOD FENCE DETAIL

SCALE: NONE

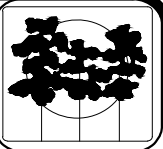

DATE MAR. 2016	DRAWN BY JH
DESIGNED BY JH	CHECKED BY

REVISIONS	

THE VILLAGE OF WELLINGTON
 Engineering Department
 12300 Forest Hill Boulevard, Wellington, Florida 33414

14022 VERONICA COURT
 HALF COURT BASKETBALL COURT
 DETAILS

JASON HANCHUK, P.E.
 FL REG. #56787

Copyright 2015 Village of Wellington
 This drawing is an instrument of service by the Village of Wellington and is not to be reproduced in part or in whole beyond the intended scope of use.

BID #: 011-16/DZ

SHEET NUMBER
 6 OF 8