

TANKLESS WATER HEATER DETAIL
N.T.S.

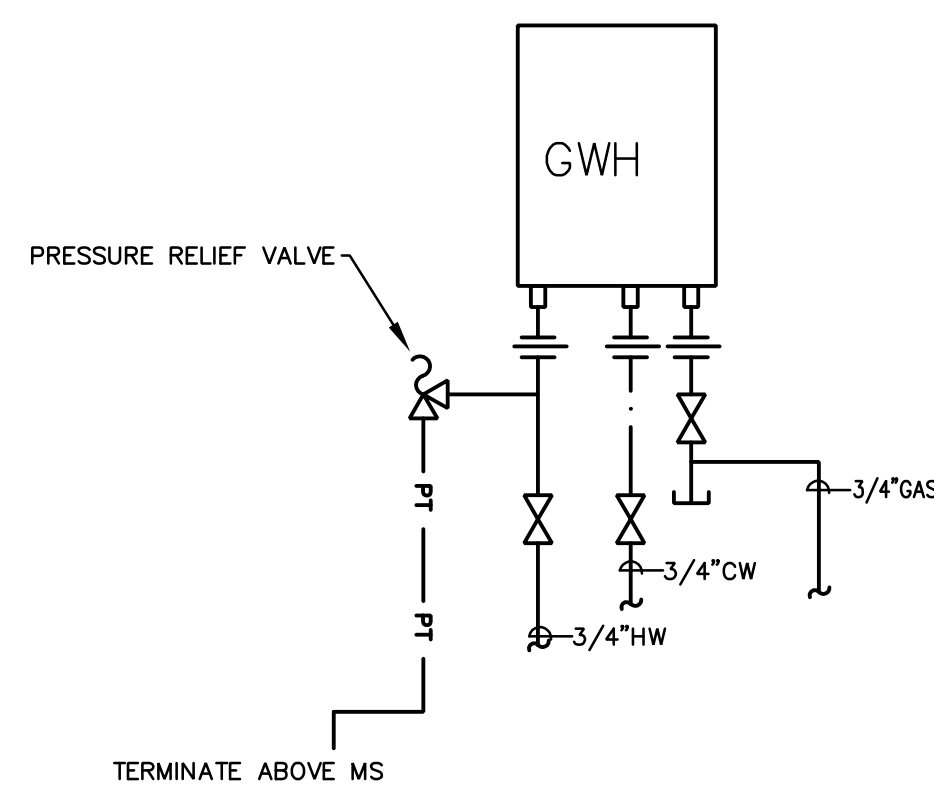

TANKLESS GAS WATER HEATER DETAIL
N.T.S.

WATER HEATER SCHEDULE-GAS				
DESIGNATION	MFG.	MODEL No.	BTU/HR	SET POINT (°F)
GWH	NORITZ	NC1991-DVC-NG	199,000	120

NOTES:
CONTRACTOR TO CONSULT MANUFACTURER FOR SPECIFIC INSTALLATION REQUIREMENTS
PROVIDE NEUTRALIZER KIT, ROUTE 3/4" DRAIN LINE TO MOP SINK.

PLUMBING FIXTURE LIST				
AMERICAN STANDARD, ELKAY & ZURN PRODUCTS ARE LISTED. SUBMIT ALTERNATE FIXTURES FOR APPROVAL. COLOR IS WHITE UNLESS OTHERWISE NOTED. ALL FIXTURES SHALL COMPLY WITH TABLE 604.4 OF F.B.C.-PLUMBING PROVIDE FIXTURES WITH REQUIRED STOP VALVES, FITTINGS, ACCESSORIES, SUPPORTS, ETC, AS REQUIRED FOR A COMPLETE FUNCTIONAL PLUMBING SYSTEM.				
TAG	MFG.	MODEL	REMARKS	
H LAV	AMERICAN STANDARD	0954-0000 6056.202	MURRO WALL HUNG HANDICAPPED LAVATORY PLUG-IN AC POWERED FAUCET, SELECTION, 1.5 GPM MANDAL RESISTANT AERATOR, PROVIDE PROVIDE BROCAR TRAP-WRAP INSULATION, NO EXCEPTIONS MOUNT RIM AT MAX. 33.5" A.F.F. - ADA COMPLIANT.	
HWC	AMERICAN STANDARD	241AA.104	HANDICAPPED TANK TYPE WATER CLOSET (1.28 GPF) CHAMPION 4 HET, ADA ELONGATED, 16-1/2" H PROVIDE ALTERNATE TANK CONFIGURATION WITH TRIP LEVER ON RIGHT SIDE WHERE REQUIRED. OLSONITE #95 SEAT.	
HS			STAINLESS STEEL HAND WASH-UP SINK, WALL MOUNTED. TO BE PROVIDED BY OWNER AND INSTALLED BY PLUMBING CONTRACTOR.	
SK-3			THREE COMPARTMENT SINK, TO BE PROVIDED BY OWNER AND INSTALLED BY PLUMBING CONTRACTOR.	
SK-2			TWO COMPARTMENT SINK, TO BE PROVIDED BY OWNER AND INSTALLED BY PLUMBING CONTRACTOR.	
MS	FIAT	MSB-2424	MOLDED STONE MOP BASIN, 830-AA FAUCET, 899-CC MOP HANGER, 832-AA HOSE AND HANGER, MSG 2424 S.S. WALL GUARD	
FD	ZURN	Z415BZ -NH-P	FLOOR DRAIN, DURA COATED CAST IRON BODY WITH BOTTOM OUTLET, POLISHED BRONZE ROUND LEVELING STRAINER TOP, NO HUB, 3" SIZE.	
FS	ZURN	FD2378 -NH3-H	NO HUB FLOOR SINK, 8" X 8", 1/2" GRATE, CAST IRON BODY WITH A WHITE ACID-RESISTANT PORCELAIN ENAMEL INTERIOR COATING, AND AN ABS ANTI-SPLASH DOME STRAINER.	
HUR	AMERICAN STANDARD	6501.010	HANDICAPPED WASHBROOK URINAL, TOP SPUD, 3/4" TOP SPUD, ZURN Z1221 CARRIER, PLATE TYPE SYSTEM, MOUNT RIM AT MAX. 17" A.F.F. - ADA COMPLIANT.	
	SLOAN	#180-1.0 ESS	HARDWIRED 1 GPF, ELECTRONIC SENSOR SOLENOID OPERATED OVERRIDE BUTTON.	
HS-2	JUST	J-770-1-S	STAINLESS STEEL SINK, FAUCET WITH PLUG IN POWER ADAPTER MOUNT RIM AT MAX. 33.5" A.F.F. - ADA COMPLIANT.	
HS-1	ADVANCE	DI-1-208 TABCO	STAINLESS STEEL SINK, K-614 SPLASH WRAP	
	T&S BRASS	B-1110	DECK MOUNTED FAUCET	

PLUMBING FIXTURE SCHEDULE								
MARK	FIXTURE	PIPE SIZE			QTY	F.U.	TOTAL	
		C.W.	H.W.	WASTE TRAP				
H LAV	LAVATORY (HANDICAPPED)	1/2"	1/2"	2"	1-1/2"	2	1	2
HWC	WATER CLOSET (HANDICAPPED)	1/2"	-	3"	INT.	2	4	8
HS	HAND SINK	1/2"	1/2"	2"	1-1/2"	3	2	6
3C SK	3 COMPARTMENT SINK	1/2"	1/2"	1-1/2"	1.W.	1	SEE FS	SEE FS
MS	MOP SINK	1/2"	1/2"	3"	3"	1	2	2
FD	FLOOR DRAIN			3"	3"	6	0	0
FS	FLOOR SINK			3"	3"	5	2	10
SK	SINK	1/2"	1/2"	2"	1-1/2"	1	2	2
HUR	URINAL (HANDICAPPED)	3/4"	-	2"	INT.	1	2	2
	TOTAL							32

NOTES:
1. ALL FIXTURES SHALL COMPLY WITH TABLE 604.4 (MAX. FLOW RATES), TABLE 604.5 (MIN. SIZES OF WATER SUPPLY), & TABLE 709.1 (MIN. SIZE OF TRAP) OF F.B.C.-PLUMBING

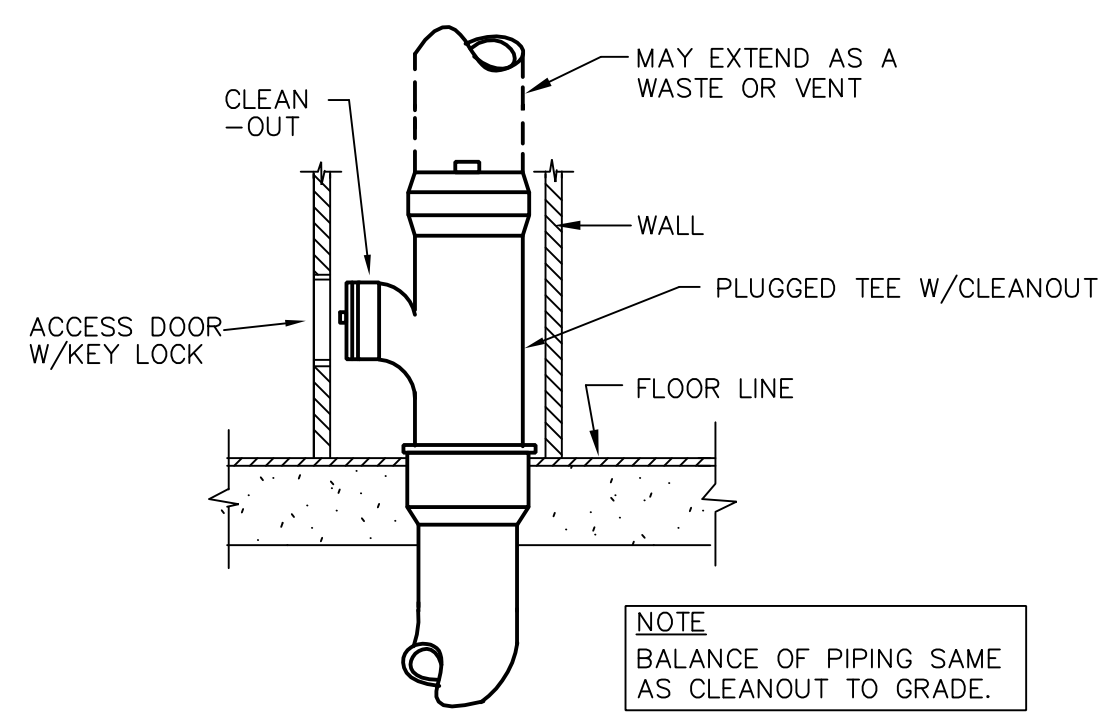

WALL CLEANOUT DETAIL
NOT TO SCALE

GENERAL PLUMBING NOTES

- ALL WORK SHALL COMPLY WITH THE FLORIDA PLUMBING CODE-2014.
- DO NOT SCALE DRAWINGS. VERIFY DIMENSIONS IN FIELD PRIOR TO COMMENCEMENT OF WORK. THE DRAWINGS ARE DIAGRAMMATIC AND INDICATE GENERAL LAYOUT OF PLUMBING SYSTEMS.
- CONTRACTOR SHALL VISIT THE EXISTING SITE (IF APPLICABLE) PRIOR TO BIDDING AND SHALL INVESTIGATE ALL CONDITIONS THAT AFFECT HIS WORK: VERIFY LOCATIONS, SIZES, DIMENSIONS, AND INVERT ELEVATIONS OF ALL ON-SITE SANITARY SEWERS, STORM DRAINS, WATER MAINS AND NATURAL GAS MAINS, AND MAKE CERTAIN THAT ALL CONNECTIONS CAN BE MADE. THE CONTRACTOR SHALL MAKE THE ARCHITECT/ENGINEER AWARE OF ANY CONFLICTS.
- CONTRACTOR SHALL REVIEW ARCHITECTURAL, STRUCTURAL, MECHANICAL AND OTHER DRAWINGS PRIOR TO BID AND SHALL COORDINATE ALL TRADES TO PROVIDE A COMPLETE PRODUCT TO AVOID CONFLICTS BETWEEN THE TRADES, AND TO DETERMINE WHICH TRADE IS TO PERFORM THE NECESSARY WORK. RESOLVE ALL QUESTIONS OR CONFLICTS WITH THE ENGINEER BEFORE ANY EQUIPMENT IS ORDERED, MATERIALS FABRICATED OR SYSTEMS INSTALLED. CONSULT THE ARCHITECT'S DRAWINGS FOR ALL GRADE AND FINISH FLOOR ELEVATIONS.
- CONTRACTOR SHALL GUARANTEE THE INSTALLATION AGAINST DEFECTS IN MATERIALS AND WORKMANSHIP WHICH MAY OCCUR UNDER NORMAL USAGE FOR A PERIOD OF ONE YEAR AFTER OWNER'S ACCEPTANCE. DEFECTS SHALL BE PROMPTLY REMEDIED WITHOUT COST TO THE OWNER.
- CONTRACTOR SHALL SECURE AND PAY FOR ALL PERMITS, FEES, INSPECTION AND TESTS. CONTRACTOR SHALL OBTAIN PERMIT AND APPROVED SUBMITTALS PRIOR TO COMMENCEMENT OF WORK OR ORDERING EQUIPMENT. PLUMBING CONTRACTOR SHALL BE PRESENT FOR ALL INSPECTIONS OF HIS WORK BY REGULATORY AUTHORITIES.
- CONTRACTOR SHALL PROVIDE RECORD DRAWINGS TO THE BUILDING OWNER AND ARCHITECT. DRAWINGS SHALL INCLUDE ALL ADDENDUM ITEMS, CHANGE ORDERS, ALTERATIONS, REWORKINGS, ETC.
- CONTRACTOR SHALL PROVIDE INSURANCE FOR PROTECTION AGAINST PUBLIC LIABILITY AND PROPERTY DAMAGE FOR THE DURATION OF THE WORK.
- TRENCHING, BACKFILL AND CONCRETE WORK ASSOCIATED WITH PLUMBING SHALL BE PERFORMED IN ACCORDANCE WITH THE APPLICABLE SPECIFICATIONS.
- CONTRACTOR SHALL PROVIDE AND INSTALL ALL SLEEVES THROUGH FLOORS AND WALLS PIPING THROUGH FLOORS SHALL BE SLEAVED, CAULKED AND FLASHED TO PREVENT LEAKAGE. SEAL ALL WALL PENETRATIONS WATERTIGHT WITH SILICONE CAULKING AND BACKER ROD, OR COVERED WITH ESCUTCHEON PLATES. IT SHALL ALSO BE THE RESPONSIBILITY OF THE PLUMBING SUBCONTRACTOR TO PROVIDE ALL LAYOUT, SLEEVING, CONCRETE CUTTING AND PATCHING, AND CONCRETE CORERSING AS REQUIRED TO COMPLETE ALL OF PLUMBING WORK. ALL LAYOUT OF REQUIRED CONCRETE CUTTING MUST BE APPROVED BY THE GENERAL CONTRACTOR PRIOR TO PLUMBING SUBCONTRACTOR'S EXECUTION OF SAME.
- LAYOUT PIPES TO FALL (CONCEALED) WITHIN PARTITION WALL OR CHASES. NOTIFY ARCHITECT IF ADDITIONAL WALL SPACE IS REQUIRED. COORDINATE PIPE DROP WITH FOOTINGS, STRUCTURAL STEEL, FIRE RATED WALLS, WHICH MAY FALL BELOW PARTITION WALL OR CHASE. MAKE NECESSARY ADJUSTMENT TO PIPING TO AVOID CONFLICT WITH BUILDING OBSTRUCTIONS. CONSULT WITH ARCHITECT AND CONTRACT DOCUMENTS FOR LOCATION OF ALL RATED WALLS, CEILINGS, FLOORS AND ROOF. FURNISH AND INSTALL APPROPRIATE AND APPROVED FIRE BARRIER AT ALL PENETRATIONS. INSTALLATION SHALL BE PER MANUFACTURERS SPECIFICATIONS.
- CONTRACTOR SHALL PROVIDE PIPE HANGERS FOR ALL PIPING. HANGER RODS AND DEVICES SHALL BE USED FOR SUPPORT OF ALL PIPING. MAKESHIFT DEVICES WILL NOT BE ACCEPTABLE. HANGER DEVICES SHALL BE SIZED TO FIT AROUND INSULATION. PROVIDE GALVANIZED STEEL SADDLES AS REQUIRED. PIPING SUPPORT SPACING SHALL COMPLY WITH THE FLORIDA PLUMBING CODE-2014.
- SANITARY, VENT PIPING AND DOMESTIC WATER PIPING SHALL BE TESTED IN ACCORDANCE WITH SECTION 312 OF THE FLORIDA PLUMBING CODE-2014.
- DIELECTRIC COUPLINGS ARE REQUIRED BETWEEN ALL DISSIMILAR METAL IN PIPING AND EQUIPMENT CONNECTIONS.
- MATERIALS AND EQUIPMENT SHALL BE NEW OF AMERICAN MANUFACTURER, FREE OF DEFECTS AND IT SHALL MEET THE REQUIREMENTS OF THE NATIONAL BOARD OF FIRE UNDERWRITERS, ASTM & ANSI SPECIFICATIONS WHERE SUCH EXIST, STANDARD AND LOCAL BUILDING CODES, AND SHALL BE SUITABLE FOR THE USE INTENDED.

WATER PIPING SYSTEM NOTES

- WATER PIPING SHALL BE COPPER TYPE "L".
- ALL FIXTURES MUST BE PROVIDED WITH READILY ACCESSIBLE STOPS AND APPROPRIATELY MARKED ACCESS PANELS. COORDINATE LOCATIONS WITH GENERAL CONTRACTOR PRIOR TO INSTALLATION.
- PROVIDE ANGLE STOPS ON ALL WATER SERVICE LINES TO FIXTURES FOR INDIVIDUAL SHUT-OFF.
- DISINFECTION OF SYSTEM. AFTER CONSTRUCTION OR MAJOR REPAIR, THE INDIVIDUAL WATER SUPPLY SYSTEM SHALL BE PURGED OF DELETERIOUS MATTER AND DISINFECTED IN ACCORDANCE TO SECTION 610 FPC-2010.
- ALL FIXTURES MUST BE PROVIDED WITH READILY ACCESSIBLE STOPS AND APPROPRIATELY MARKED ACCESS PANELS. COORDINATE LOCATIONS WITH GENERAL CONTRACTOR PRIOR TO INSTALLATION.
- PROVIDE A WATER HAMMER ARRESTOR ON ALL WATER SUPPLY LINES SERVING FLUSH VALVE PLUMBING FIXTURES, SOLENOID VALVES, ETC. INCLUDING OTHER FIXTURES OR EQUIPMENT WITH QUICK CLOSING VALVES (ICE MAKERS, & DISHWASHERS). USE SIOUX CHIEF SHOCK ARRESTORS, P.D.I.#A ; 1/2"CONN., P.D.I.#B ; 3/4"CONN. P.D.I.#C ; 1"CONN., APPROVED FOR INSTALLATION WITH NO ACCESS PANEL REQUIRED. CONFORMS WITH ANSI/ASSE 1010 STANDARDS.
- PROVIDE AUTOMATIC TRAP PRIMER ON COLD WATER CONNECTION TO LAVATORY FIXTURE WITH COLD WATER TUBE TO FLOOR DRAIN AUXILIARY INLET FITTING. FLOOR DRAINS IN AREAS WHERE A LAVATORY (TRAP PRIMER) CONNECTION IS NOT AVAILABLE, PROVIDE A TRAP PRIMER DISTRIBUTION UNIT PRECISION PLUMBING PRODUCTS, MODEL PR-500 (OR APPROVED EQUAL) AND A SHUT-OFF VALVE IN ACCESSIBLE AREA.
- ESCUTCHEONS SHALL BE CHROME PLATED BRASS WITH LOCKING SCREWS WHERE PIPES PASS THROUGH FINISHED WALLS.

SANITARY WASTE SYSTEM

- SANITARY WASTE AND VENT PIPING SHALL BE SOLID WALL SCHEDULE 40 PVC. PIPING MATERIALS SHALL BEAR LABEL, STAMP, OR OTHER MARKINGS OF SPECIFIED TESTING AGENCY. INSTALLATION SHALL BE IN STRICT CONFORMANCE WITH MANUFACTURER'S REQUIREMENTS.
- MAINTAIN A MINIMUM SLOPE OF 1/4" PER FOOT FOR DRAIN PIPING 2-1/2" OR LESS, AND 1/8" PER FOOT FOR PIPES 3" AND LARGER.
- ALL VENT AND BRANCH VENT PIPES SHALL BE SO GRADED AND CONNECTED AS TO DRAIN BACK TO THE DRAINAGE PIPE BY GRAVITY.
- EVERY DRY VENT SHALL RISE VERTICALLY TO A MINIMUM OF 6 INCHES ABOVE THE FLOOD LEVEL RIM OF THE HIGHEST TRAP OR TRAPPED FIXTURE BEING VENTED.
- ALL INDIRECT WASTE PIPING SHALL DISCHARGE THROUGH AN AIR GAP INTO A WASTE RECEPTOR. ALL WASTE RECEPTORS SHALL BE TRAPPED & VENTED. ALL INDIRECT WASTE PIPING THAT EXCEEDS 24" IN DEVELOPED LENGTH MEASURED HORIZONTALLY OR 48" IN TOTAL DEV. LENGTH SHALL BE TRAPPED.

PLUMBING LEGEND

CO	CLEAN OUT	— — — — —	SANITARY SEWER PIPING
CW	DOMESTIC COLD WATER	— — — — —	VENT PIPING
HW	DOMESTIC HOT WATER	— — — — —	DOMESTIC COLD WATER PIPING
SAN	SANITARY	— — — — —	HOT WATER PIPING
⊗	BALL VALVE	— GW —	GREASE WASTE PIPING
VTR	VENT THRU ROOF	— IW —	IN-DIRECT WASTE PIPING
AAV	AIR ADMITTANCE VALVE		
V.I.F.	VERIFY IN FIELD		
WHA	WATER HAMMER ARRESTER- PDI #		
SOV	SHUT-OFF VALVE		
U.G.	UNDER GROUND		
(E)	EXISTING		
⊙	POINT OF CONNECTION		

CONNECTION TO EXISTING PLUMBING SYSTEM NOTES

- INSTALLATION OF WORK AND NEW CONNECTION TO EXISTING PLUMBING LINES SHALL BE MADE AT TIME WHICH WILL NOT INTERFERE OR INTERRUPT THE NORMAL BUILDING OPERATION.
- EXACT LOCATIONS, SIZE, AND ELEVATION OF EXISTING PIPING SHALL BE FIELD VERIFIED BEFORE START OF ANY WORK. ACTUAL FIELD CONDITIONS MAY REQUIRE ADJUSTMENT OR MODIFICATION TO PROPOSED ROUGHING, LAYOUT, AND ROUTING OF PIPING, INCLUDING POINT OF CONNECTION TO EXISTING WORK OF ADEQUATE SIZE TO ACCOMMODATE NEW WORK.
- PROVIDE NECESSARY ADJUSTMENT OF NEW INSTALLATION DUE TO INTERFERENCE WITH BUILDING CONDITIONS, INCLUDING WORK OF OTHER TRADES.
- PIPING MATERIAL, VALVES, PIPE SUPPORTS, PIPE COVERING, ETC. USED IN THE INSTALLATION OF WORK OF THIS CONTRACT SHALL BE NEW AND SHALL MATCH EXISTING, PROVIDING SAME MEETS ALL APPLICABLE BUILDING AND PLUMBING CODES.
- PROVIDE NEW PLUMBING ROUGHING WITH CONNECTIONS NECESSARY OR REQUIRED FOR PROPER FUNCTION OF PLUMBING EQUIPMENT.
- EXISTING PIPING SHALL BE MODIFIED AND/OR REMOVED TO POINT THAT WOULD ACCOMMODATE CONNECTION OF NEW (WATER AND WASTE) PLUMBING ROUGHING.
- ROUTING OF NEW PIPING AND POINT OF CONNECTION TO EXISTING PIPING IS BASED ON ASSUMPTION THAT PIPING IS AT LOCATION SHOWN ON PLAN.
- PROVIDE NECESSARY TEST TO DETERMINE TIGHTNESS OF EXISTING AND NEW PLUMBING PIPING SYSTEMS. ALL LEAKS AND OPEN OUTLETS FOUND DURING TEST SHALL BE REPAIRED, CAPPED OR PLUGGED, PERFORM ADDITIONAL TEST UNTIL IT IS DETERMINED THAT THE PLUMBING PIPING SYSTEMS IS WATER TIGHT.
- ALL OPENINGS, HOLES, ETC; MADE FOR THE REMOVAL OF PLUMBING PIPING, FIXTURES, ETC; SHALL BE PATCHED WITH MATERIAL TO MATCH EXISTING.
- IF FIELD CONDITION FINDS THAT EXISTING SANITARY, VENT, HOT AND COLD WATER LINES CAN BE UTILIZED, CONNECT NEW SANITARY, VENT, HOT AND COLD WATER LINES TO EXISTING. MAKE NECESSARY ADJUSTMENTS TO ACCOMMODATE NEW SANITARY, VENT AND WATER LINES.

GAS SYSTEM NOTES

- GAS PIPING SHALL BE SCHEDULE 40 GALV STEEL WITH MALLEABLE THREADED FITTINGS.
- CONTRACTOR SHALL PAY ALL FEES AND OBTAIN ALL PERMITS REQUIRED FOR THE INSTALLATION OF GAS SERVICE TO BUILDING, SEPARATE GAS PERMIT WILL BE REQUIRED.
- ALL NATURAL GAS LINES SHALL BE BLOWN CLEAN OF DEBRIS AND FOREIGN MATTER WITH COMPRESSED AIR PRIOR TO FINAL CONNECTION TO EQUIPMENT.
- FROM GAS HEADER INSTALL PIPE DROP WITH A 6" LONG SEDIMENT TRAP, PROVIDE GAS SHUT OFF VALVE ACCESSIBLE FOR MANUAL SHUT-OFF OF GAS TO EQUIPMENT.
- CONTINUE GAS SERVICE AND PROVIDE CONNECTION TO MAIN GAS SERVICE LINE.
- LOCATION OF CONNECTION, INCLUDING GAS METER, MAIN SHUT-OFF VALVE, ETC., SHALL BE COORDINATED WITH LOCAL GAS COMPANY.
- CONTRACTOR SHALL COORDINATE ALL OWNER SUPPLIED EQUIPMENT PIPING REQUIREMENTS PRIOR TO INSTALLATION OF PIPING SYSTEMS.
- PROVIDE PIPE HANGERS FOR ALL PIPING. HANGER RODS AND DEVICES SHALL BE USED FOR SUPPORT OF ALL PIPING. MAKESHIFT DEVICES WILL NOT BE ACCEPTABLE. PROVIDE GALVANIZED STEEL SADDLES AS REQUIRED. PIPING SUPPORT SPACING SHALL COMPLY WITH THE FLORIDA PLUMBING CODE-2010, TABLE 308.5.
- CONTRACTOR SHALL PROVIDE NECESSARY REGULATORS FOR EACH APPLIANCE TO DROP GAS LINE PRESSURE TO APPLIANCE'S REQUIREMENTS.

MICHAEL A. BASSFORD
2107 N.E. 17TH AVENUE
WILTON MANORS, FL 33505
PHONE: (654) 298-0700
Email: mbassford@aol.com

REVISIONS	BY

INTERIOR IMPROVEMENTS
FIRE UP PIZZA
8170 OKEECHOBEE BLVD. - SUITES 1 & 2
SEDONA COMMONS - BUILDING #7
WEST PALM BEACH, FLORIDA

KUOPPALA & ASSOCIATES, P.A.
ARCHITECTS
FLORIDA ARCHITECT #09461
ROBERT E. KUOPPALA
LICENSE #AAC-001656
925 SOUTH MILITARY TRAIL, SUITE D-10
WEST PALM BEACH, FLORIDA 33415
(561) 682-1909-OFF.
(561) 682-1975-FAX.

DRAWN	MB
CHECKED	MB
DATE	APRIL 26, 2016
SCALE	AS NOTED
COMM. NO.	16-07
SHEET	