

REVISIONS

1	
2	
3	
4	
5	
6	
7	
8	
9	
10	

ALL WORK SHALL BE ACCORDING TO THE LATEST EDITION OF THE INTERNATIONAL MECHANICAL AND ELECTRICAL HANDBOOK, 10TH EDITION, 2002, UNLESS OTHERWISE SPECIFIED. THE CONTRACTOR SHALL BE RESPONSIBLE FOR OBTAINING ALL NECESSARY PERMITS AND APPROVALS FROM THE APPROPRIATE AGENCIES. THE CONTRACTOR SHALL BE RESPONSIBLE FOR OBTAINING ALL NECESSARY PERMITS AND APPROVALS FROM THE APPROPRIATE AGENCIES. THE CONTRACTOR SHALL BE RESPONSIBLE FOR OBTAINING ALL NECESSARY PERMITS AND APPROVALS FROM THE APPROPRIATE AGENCIES.

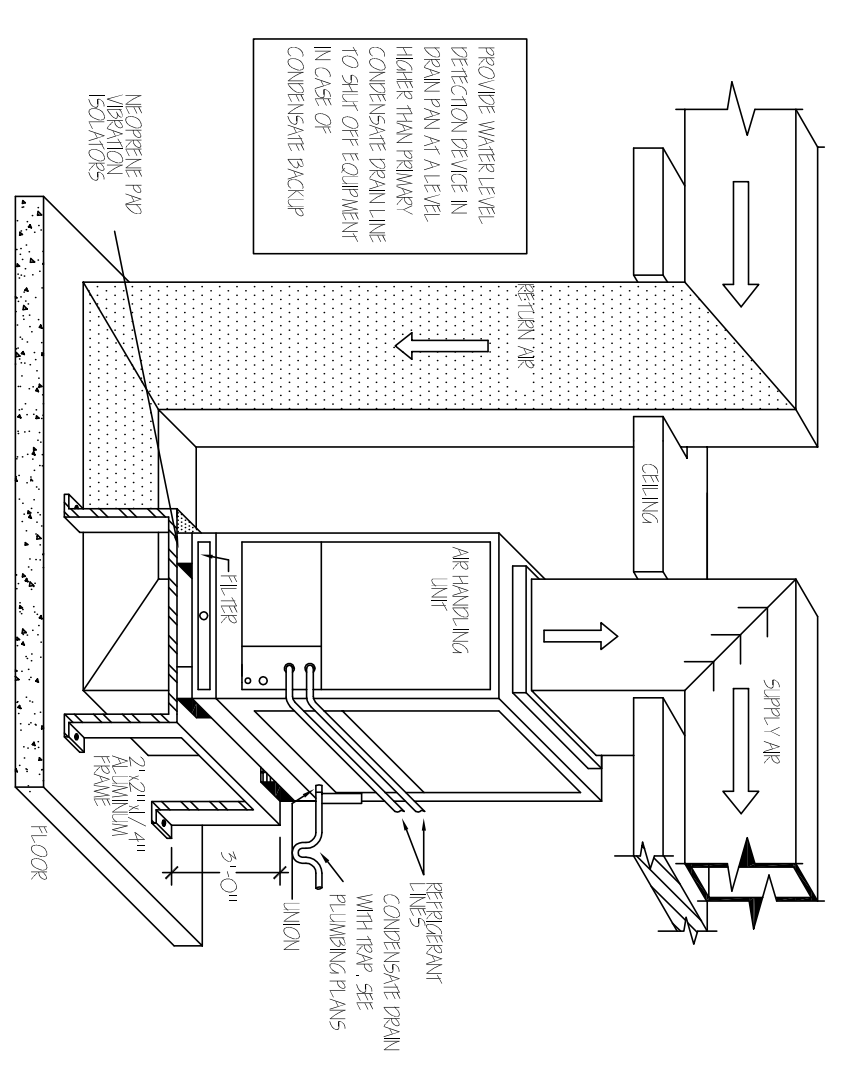

AIR HANDLER AH-1 DETAIL

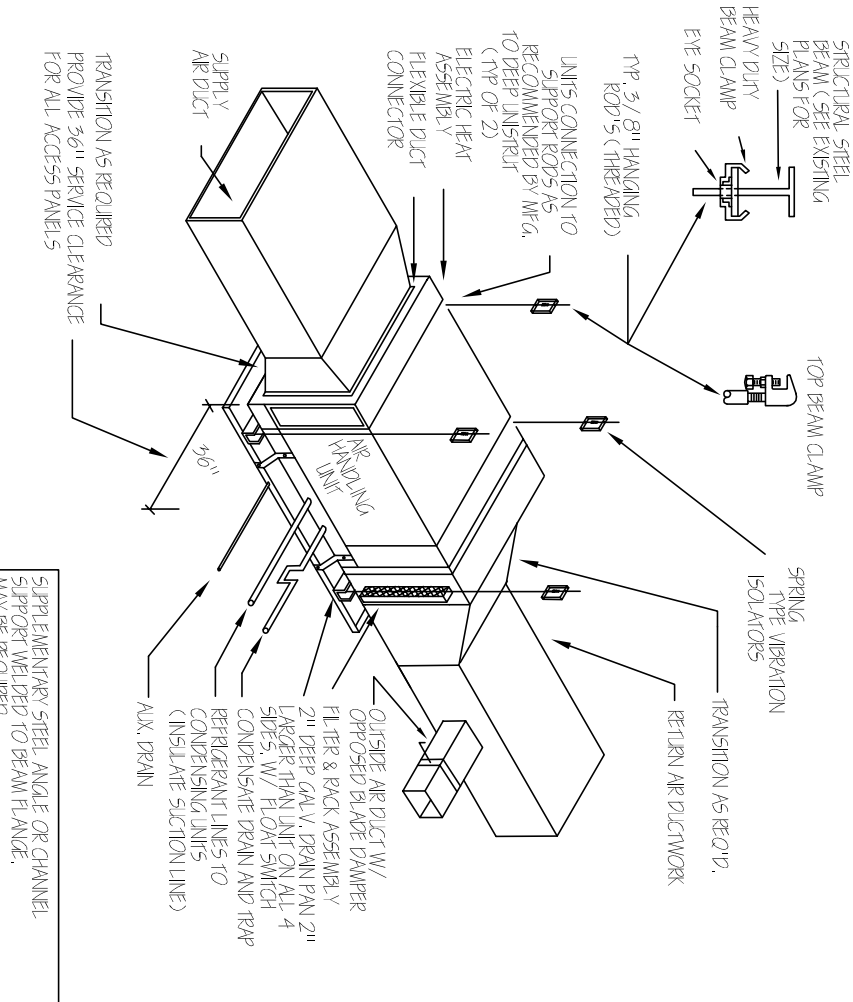

AIR HANDLER AH-1 DETAIL

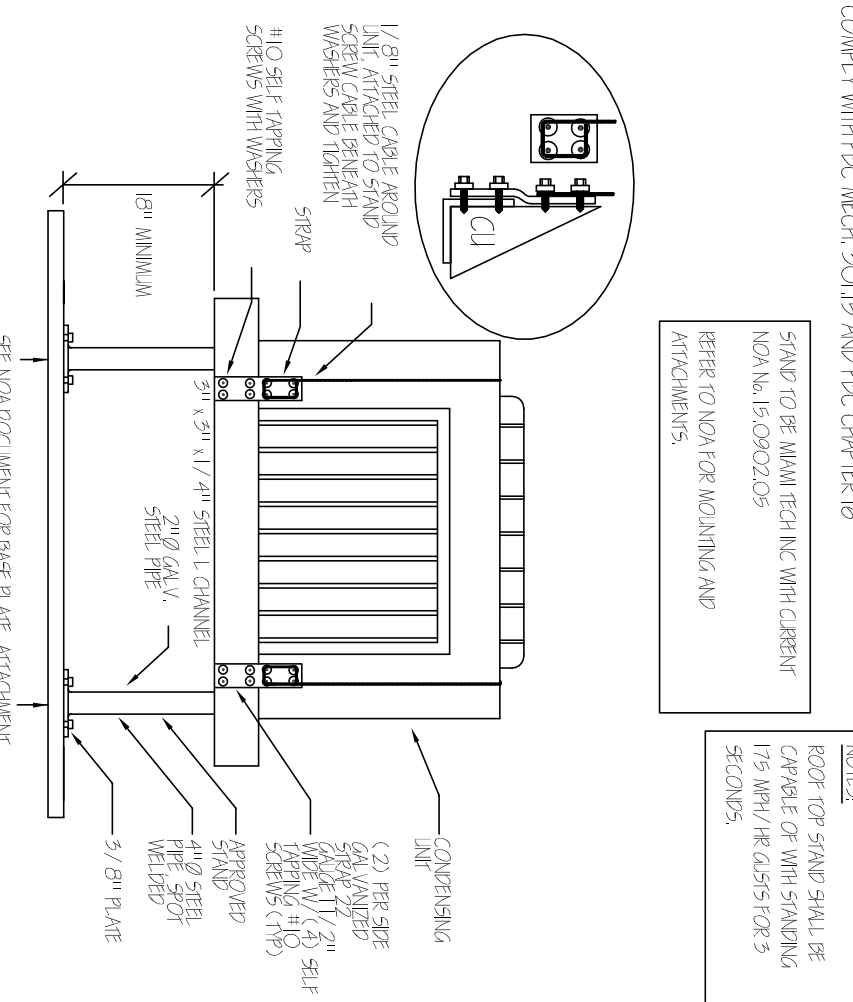

CONDENSER MOUNTING W/ HURRICANE TIE DOWNS DETAIL

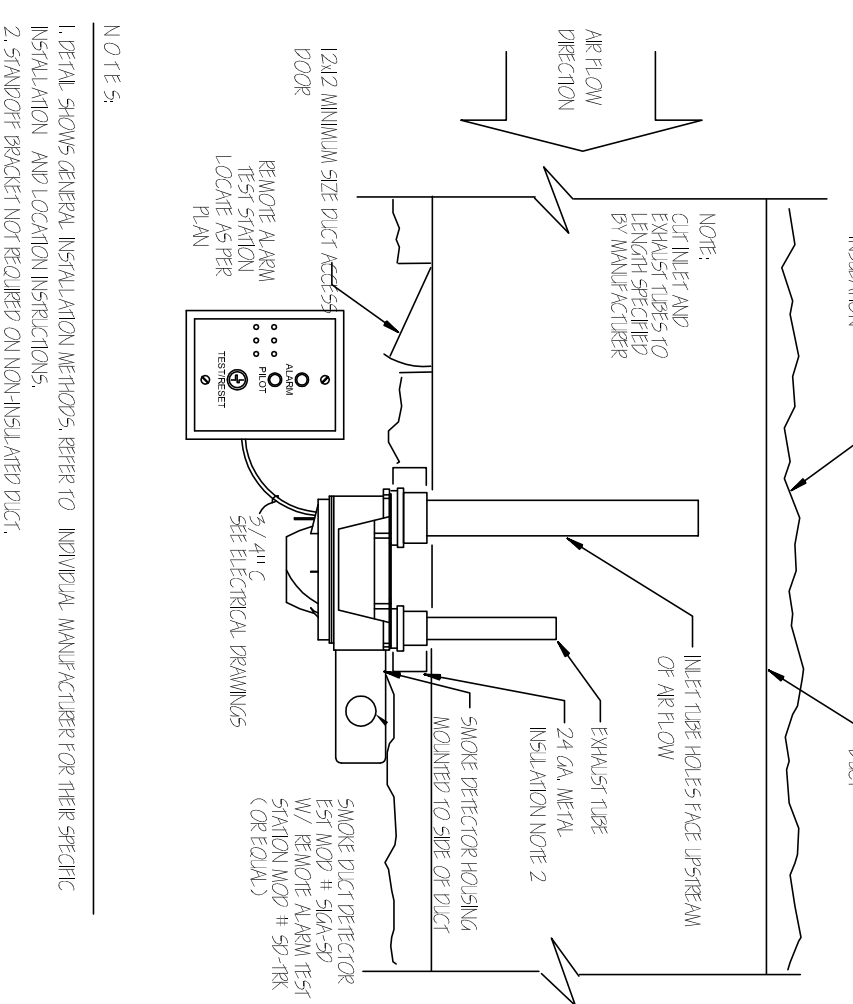

DUCT MOUNTED SMOKE DETECTOR DETAIL

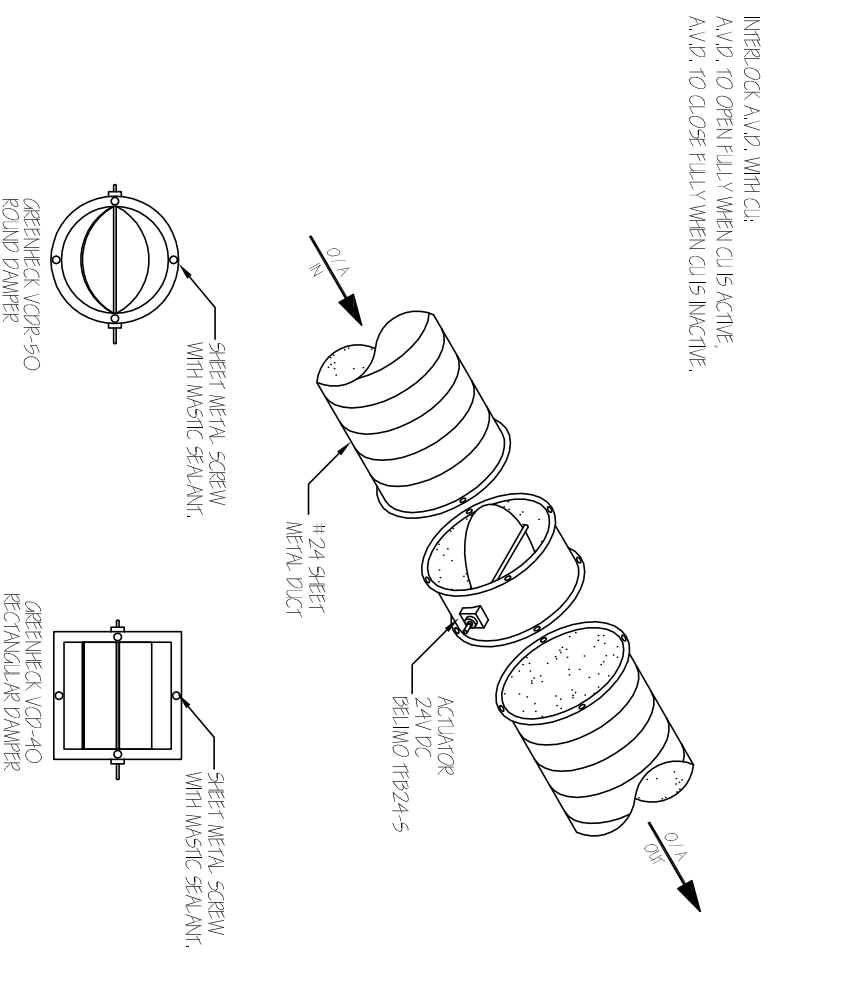

AUTOMATIC VOLUME DAMPER (A.V.D) DETAIL

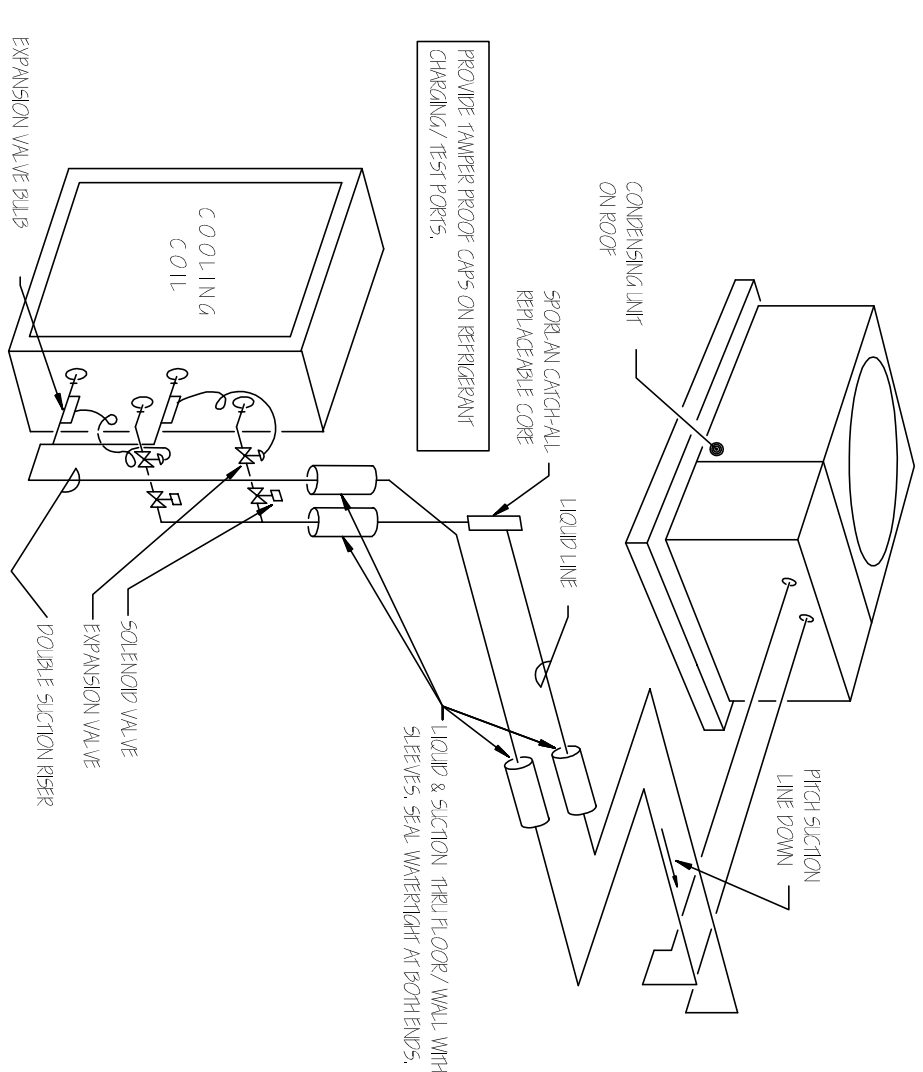

REFRIGERANT PIPING DETAIL

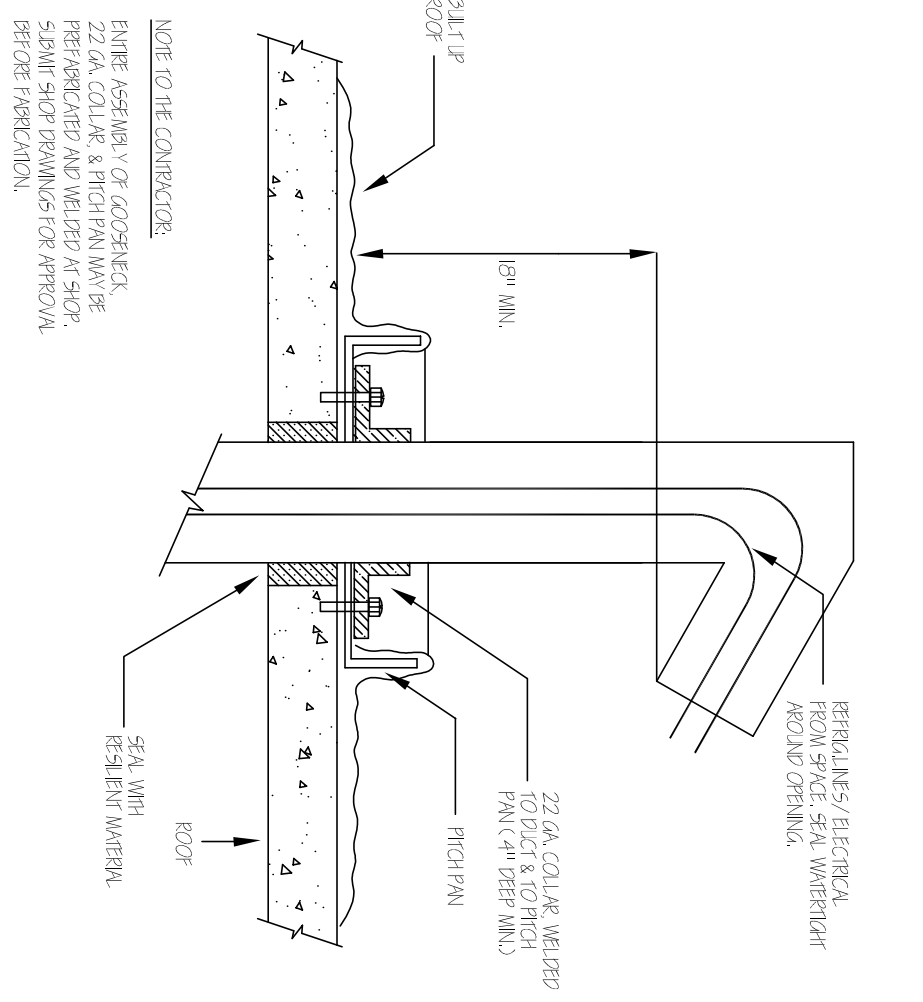

REFRIGERANT PIPING DETAIL

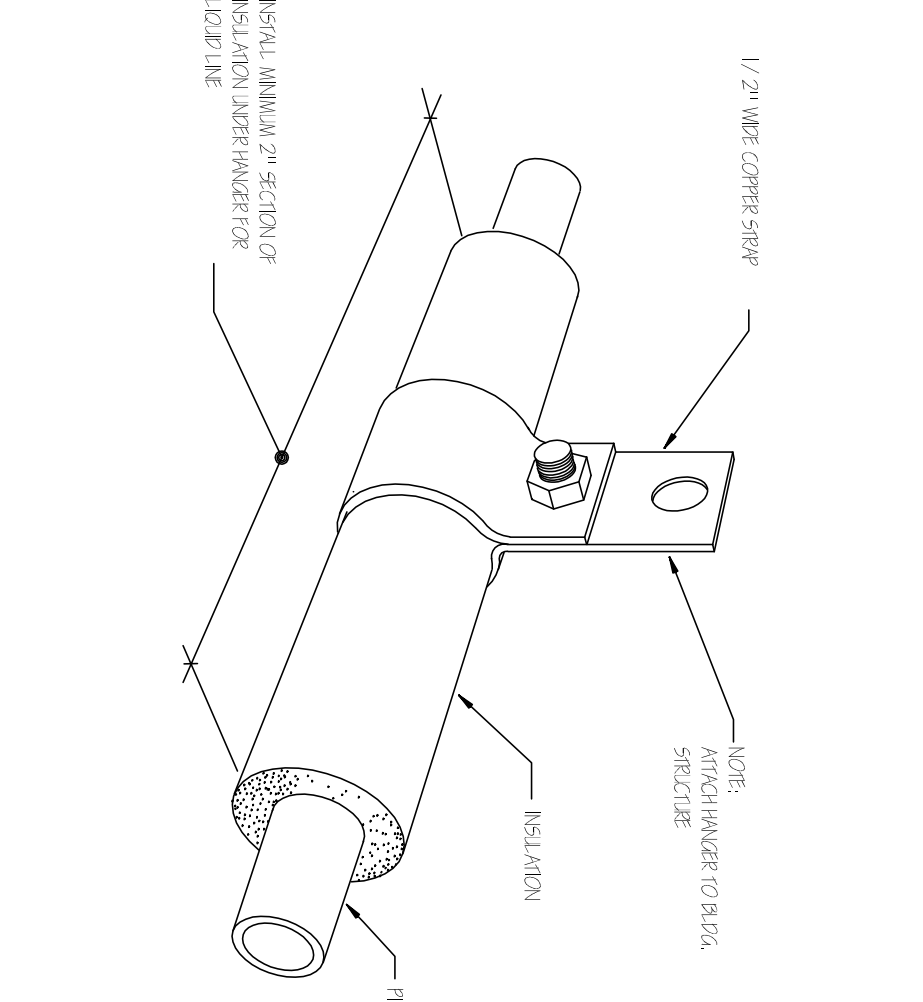

REFRIGERANT PIPING DETAIL

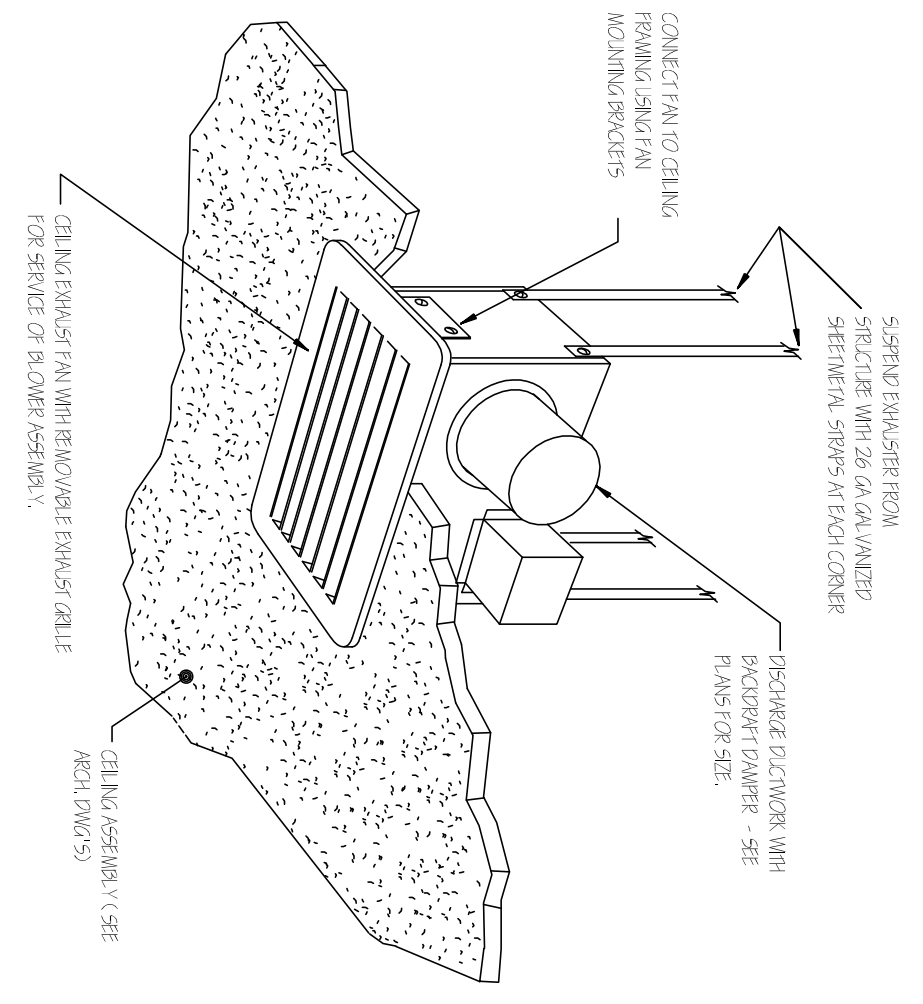

CEILING MOUNTED FAN DETAIL

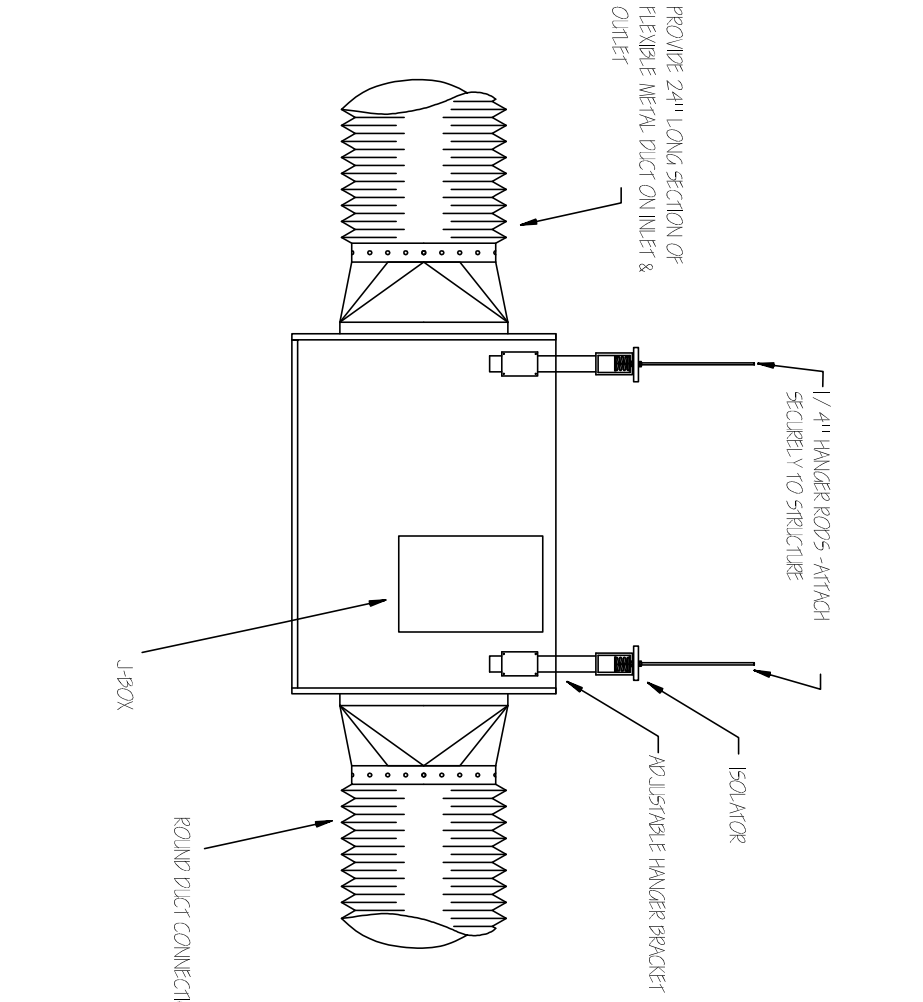

IN-LINE EXHAUST FAN DETAIL

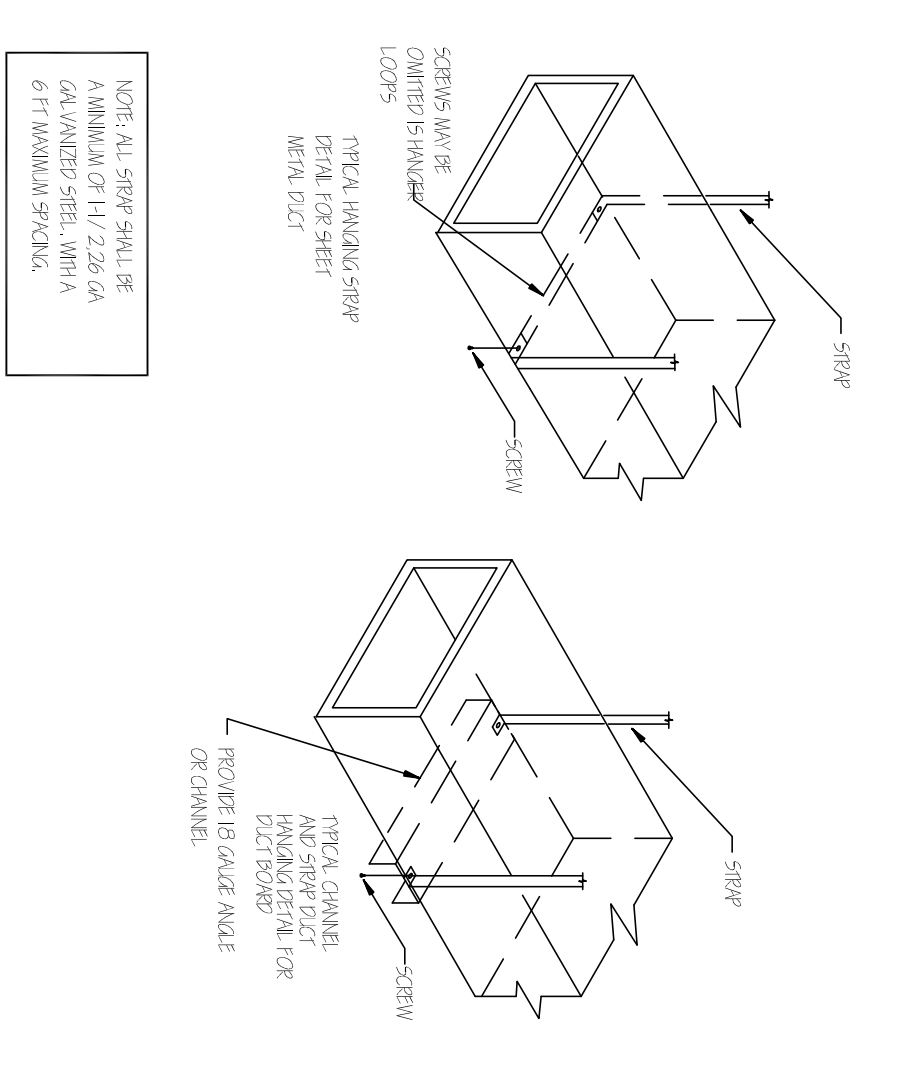

METHODS OF HANGING RIGID DUCT DETAIL

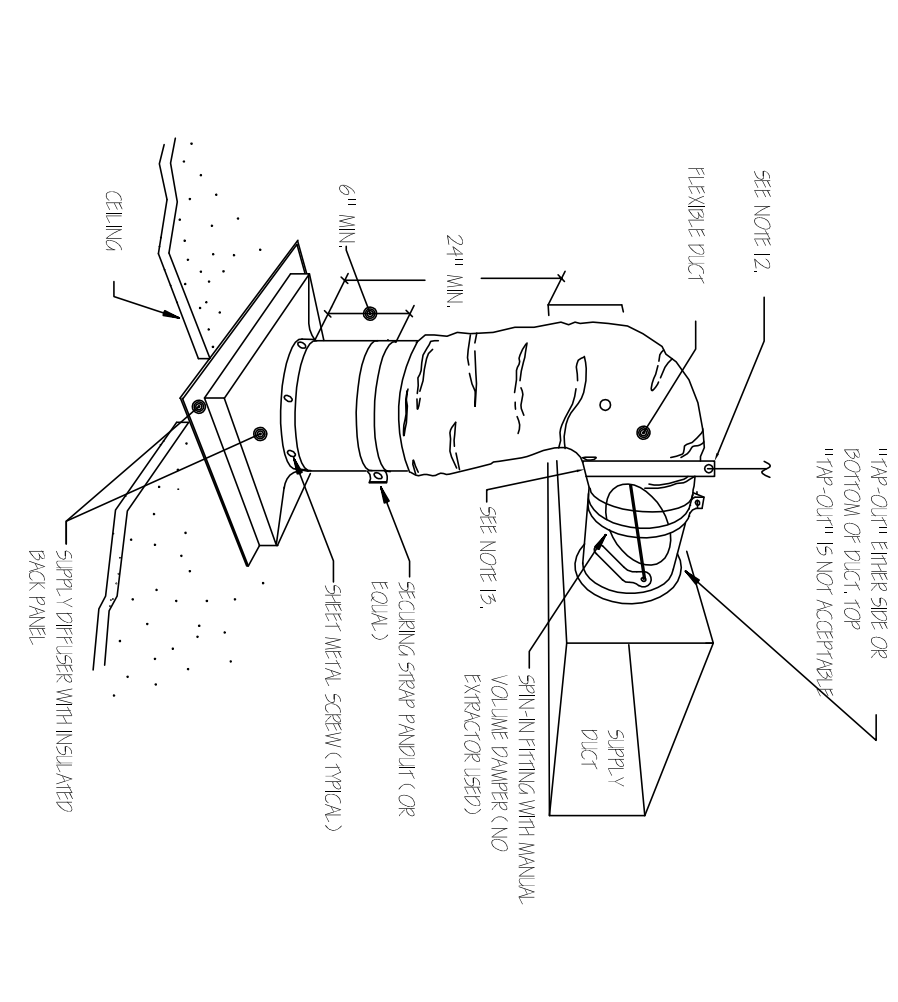

FLEX DUCT HANGING AND CONNECTION DETAIL

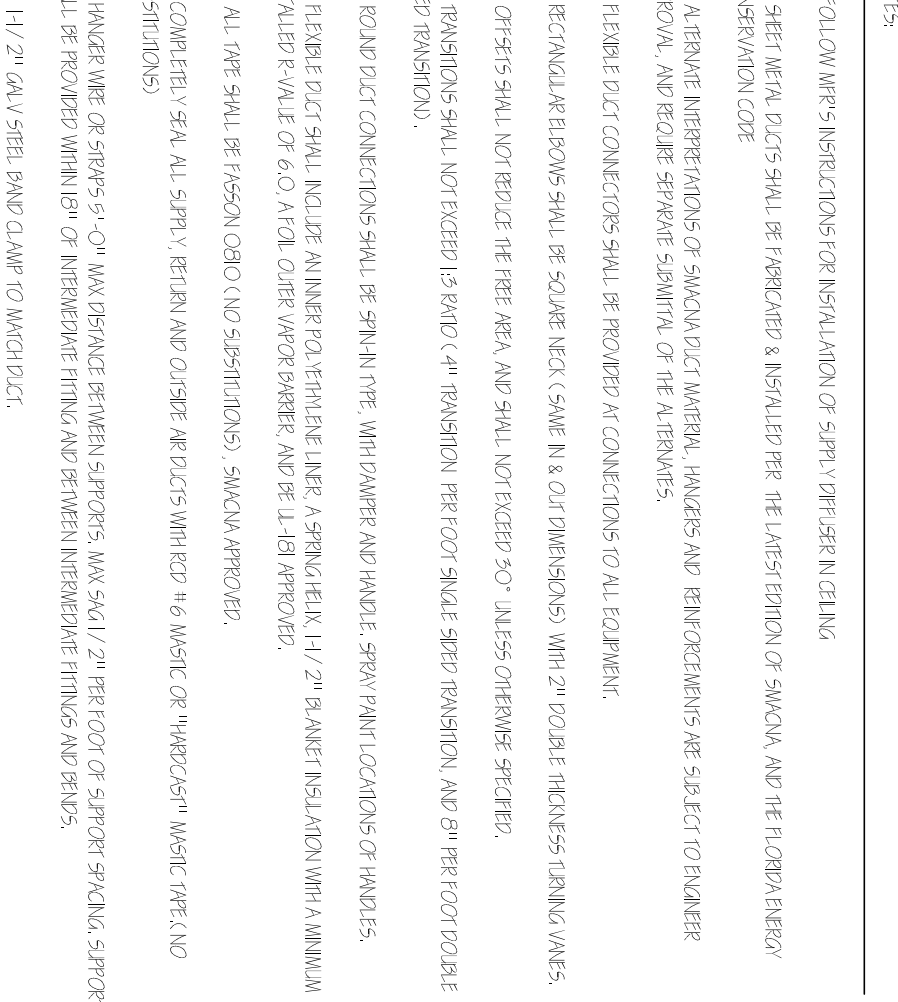

LOW PRESSURE DUCT VOLUME DAMPER REQ. DETAIL

- NOTES:
1. FOLLOW ALL SPECTIFICATIONS FOR INSTALLATION OF SPLIT SYSTEM DUCTING.
  2. SHEET METAL DUCTS SHALL BE FABRICATED & INSTALLED PER THE FABRICATION OF SIMON AND PER FLORIDA ENERGY CONSERVATION CODE.
  3. ALL EXISTING NEIGHBORHOODS OF SIMON DUCT WORK, HANGERS AND BRACKETS MUST BE SUBJECT TO INSPECTOR APPROVAL AND BECOME SERVICE QUALITY OF THE AIR BRANES.
  4. FLEXIBLE DUCT CONNECTIONS SHALL BE PROVIDED AT CONNECTIONS TO ALL EQUIPMENT.
  5. FLEXIBLE DUCT CONNECTIONS SHALL BE SCREWED TO ALL EQUIPMENT.
  6. FLEXIBLE DUCT SHALL NOT BE USED FOR CONDENSING COILS.
  7. FLEXIBLE DUCT SHALL NOT BE USED FOR CONDENSING COILS.
  8. FLEXIBLE DUCT SHALL NOT BE USED FOR CONDENSING COILS.
  9. FLEXIBLE DUCT SHALL NOT BE USED FOR CONDENSING COILS.
  10. ALL WORK SHALL BE PERFORMED IN ACCORDANCE WITH SIMON APPROVAL.
  11. CONDENSING COIL SHALL BE INSTALLED WITH PROPER SLOPE.
  12. HANGERS AND SUPPORTS SHALL BE INSTALLED WITH PROPER SLOPE.
  13. HANGERS AND SUPPORTS SHALL BE INSTALLED WITH PROPER SLOPE.
  14. HANGERS AND SUPPORTS SHALL BE INSTALLED WITH PROPER SLOPE.

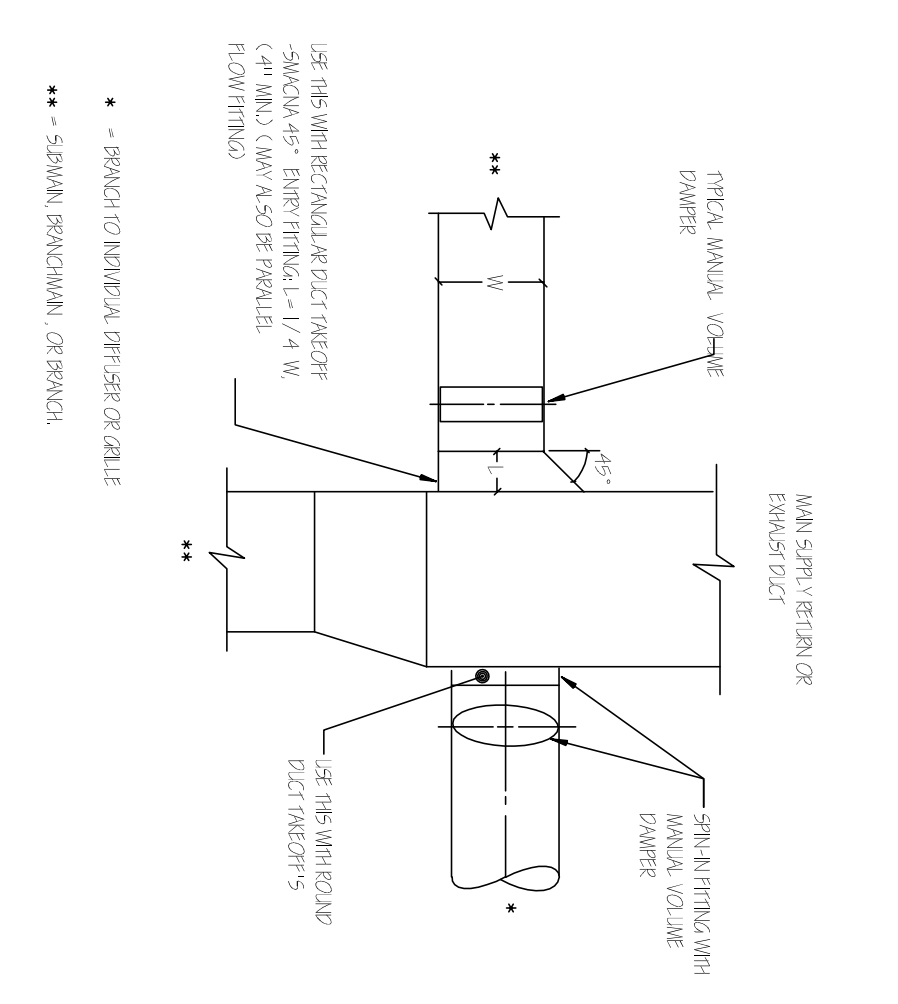

LIFE FELLOWSHIP  
11401 WEST SAMPLE ROAD  
CORAL SPRINGS, FL. 33065

**RWB**  
Linares  
ARCHITECTURE

1600 SOUTH DIXIE HWY., SUITE 400  
BOCA RATON, FLORIDA 33432  
PHONE 561-391-0081 FAX 561-391-0085  
EMAIL mail@rwb-arch.com

**Associated Professional Design**  
Consulting Engineers

500 NE SPANHAMMER BLVD, SUITE 205, BOCA RATON, FLORIDA 33491  
PHONE: 561-419-8977. INFO@APD-ENGINEERING.COM  
MCKENNA WHITE, LICENSE P.E. FLORIDA LICENSE NO. 593999  
CA. LIC. NO. 31328