

ARCHITECT
 SLATTERY & ASSOCIATES
 2060 N.W. BOCA RATON BLVD.
 BOCA RATON, FLORIDA 33431
 TEL (561) 392-3848
 CONTACT: CLIFF ROBERSON, P.M.

OWNER

WOODFIELD HUNT CLUB HOME OWNER'S ASSOC.
 C/O HAWKEYE MANAGEMENT, INC.
 3901 N. FEDERAL HWY., SUITE #202
 BOCA RATON, FLORIDA 33431
 TEL: (561) 392-1600
 CONTACT: MICHAEL MORGAN

PROPERTY MANAGER

HAWKEYE MANAGEMENT, INC.
 3901 N. FEDERAL HWY. SUITE #202
 BOCA RATON, FLORIDA 33431
 TEL: (561) 392-1600
 CONTACT: MICHAEL MORGAN

GENERAL CONTRACTOR

T.B.D.
 T.B.D.
 T.B.D.
 TEL: T.B.D.
 CONTACT: T.B.D.

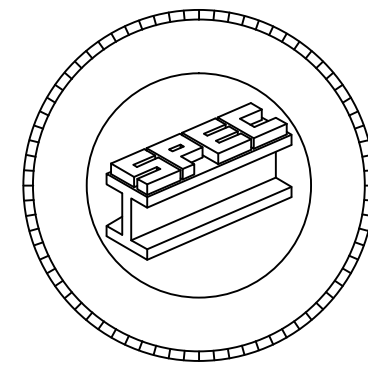

STRUCTURAL ENGINEER

SPECIALTY ENGINEERING CONSULTANTS, INC.
 1599 S.W. 30TH AVE., SUITE 20
 BOYNTON BEACH, FLORIDA 33426
 TEL: (561) 752-5440
 CONTACT: ADAM LeBLANC, P.E.



M.E.P. ENGINEER

F.A.E. CONSULTING
 700 WEST HILLSBORO BLVD., BLDG. 1, SUITE 204
 DEERFIELD BEACH, FLORIDA 33441
 TEL (561) 391-9292
 CONTACT: KAROLINA SCHAFFNER, P.M.



CIVIL ENGINEER

D.C.E.S.
 2295 N.W. CORPORATE BLVD., SUITE 125
 BOCA RATON, FLORIDA 33431
 TEL (561) 750-3717
 CONTACT: HOWARD DIECHERT, P.E.



LANDSCAPE ARCHITECT

A. GRANT THORNBOROUGH & ASSOCIATES
 132 N. SWINTON AVE.
 DELRAY BEACH, FLORIDA 33444
 TEL (561) 276-8777
 CONTACT: A. GRANT THORNBOROUGH A.S.L.A.

INTERIOR DESIGNER

WELLS DESIGN GROUP
 551 N.W. 77TH ST., SUITE 107
 BOCA RATON, FLORIDA 33487
 TEL (561) 998-4851
 CONTACT: SUSAN WELZIEN, PRESIDENT

PROPOSED PROJECT FOR: WOODFIELD HUNT CLUB CLUBHOUSE ADDITION & RENOVATIONS

4420 WOODFIELD BLVD.
 BOCA RATON, FLORIDA

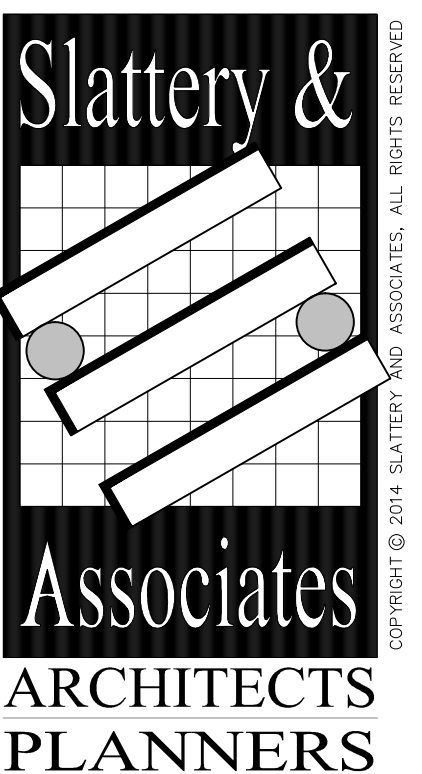

DATE OF SEAL: 7-27-16

CONSTRUCTION DOCUMENT SET JULY 21, 2016

PROJECT TITLE	WOODFIELD H.C. CLUBHOUSE RENOVATIONS
PROJECT ADDRESS	4420 WOODFIELD BLVD. BOCA RATON, FLORIDA
PROJECT NUMBER	2014-33
DRAWING NUMBER	A000