

1  
A301  
**RESTROOM PLAN**  
SCALE: 1/4" = 1'-0"  
(SEE 'ID' DWGS. FOR RESTROOM FIXTURE & FINISHES SPECIFICATIONS)

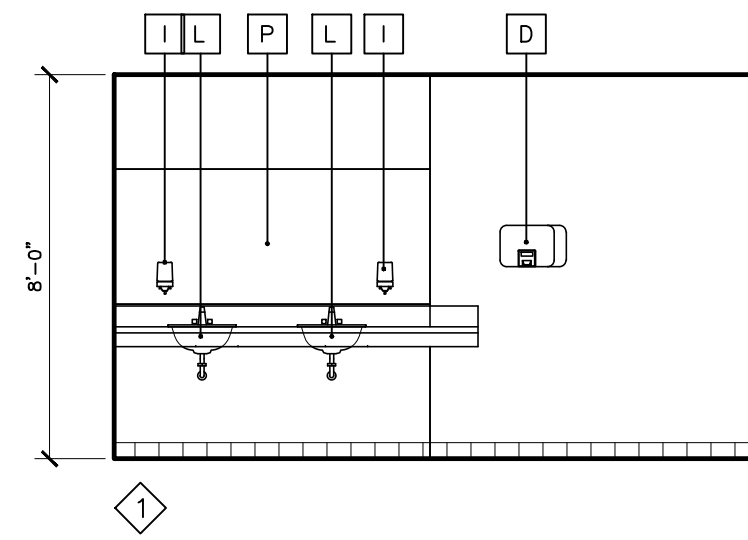

**ELEVATIONS**

(SEE 'ID' DWGS. FOR RESTROOM FIXTURE & FINISHES SPECIFICATIONS)

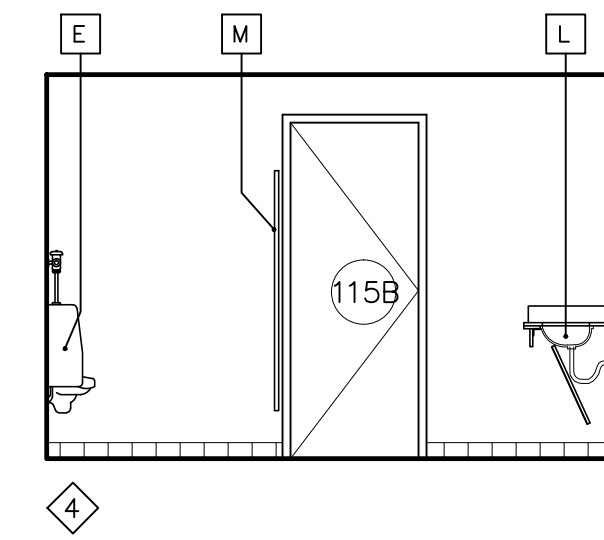
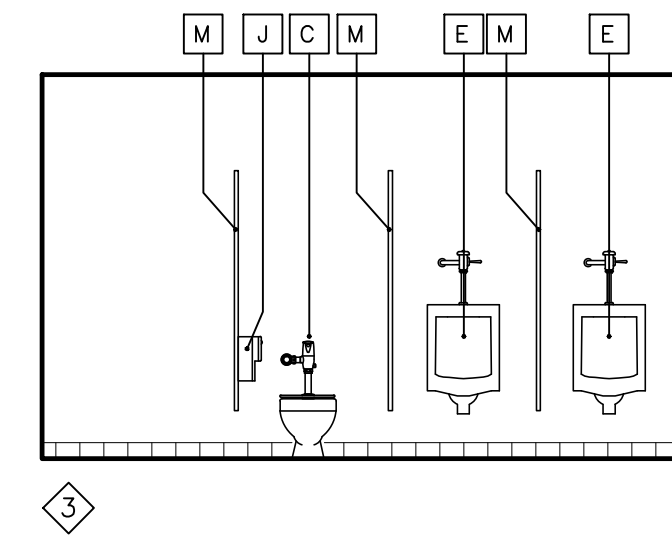
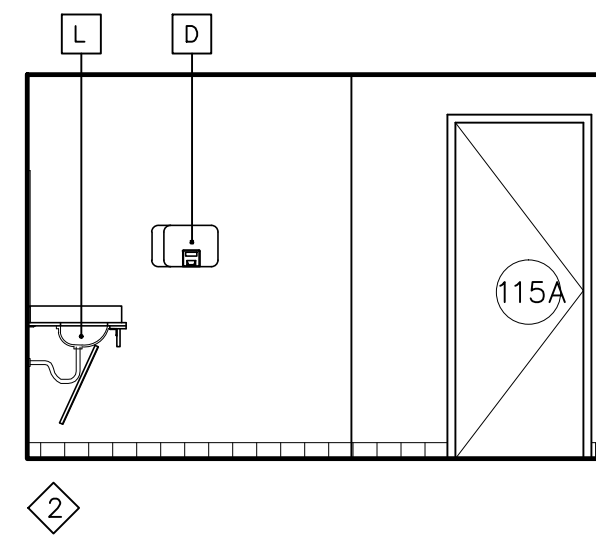

SCALE: 1/4" = 1'-0"

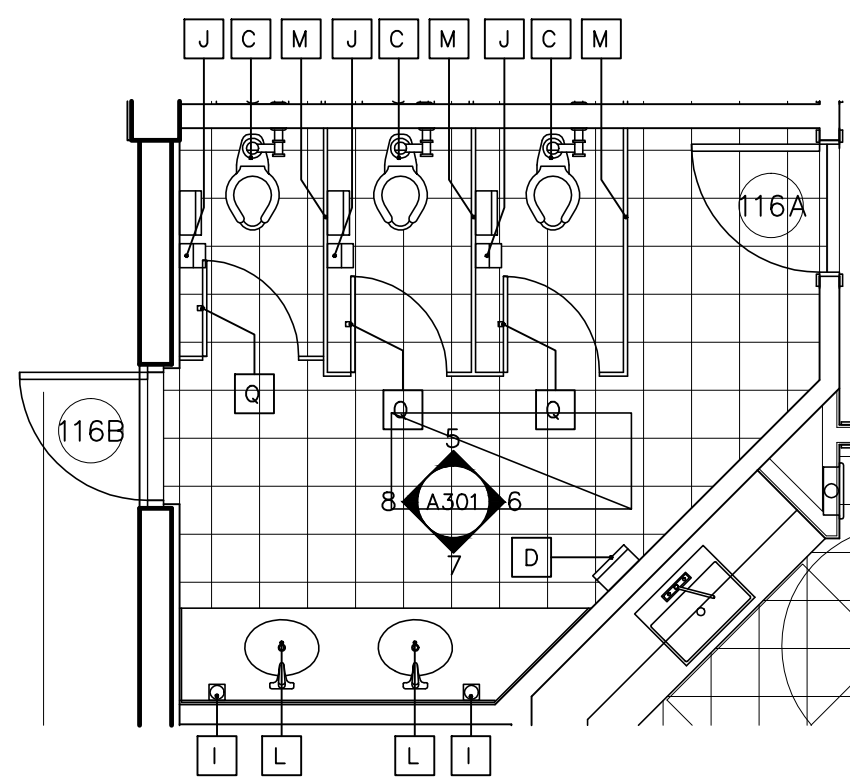

2  
A301  
**RESTROOM PLAN**  
SCALE: 1/4" = 1'-0"  
(SEE 'ID' DWGS. FOR RESTROOM FIXTURE & FINISHES SPECIFICATIONS)

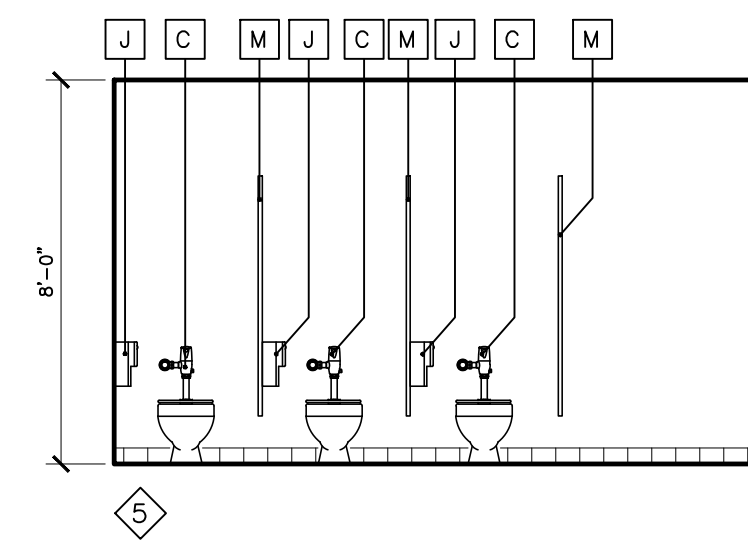

**ELEVATIONS**

(SEE 'ID' DWGS. FOR RESTROOM FIXTURE & FINISHES SPECIFICATIONS)

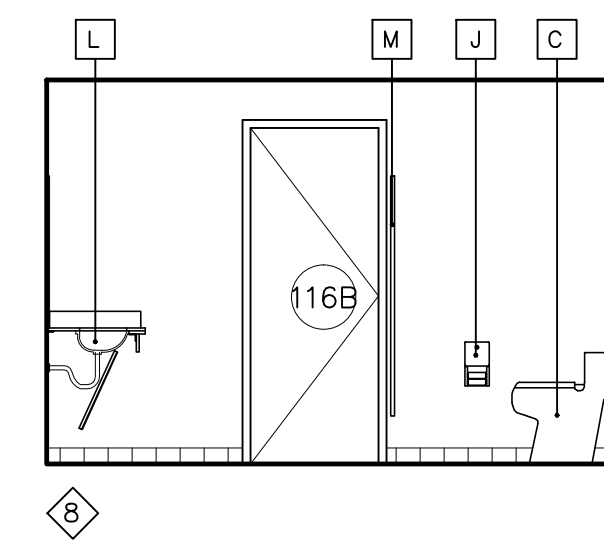
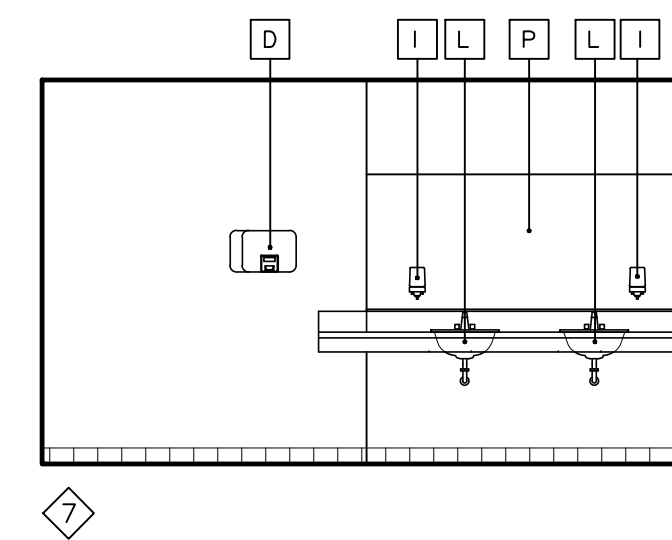
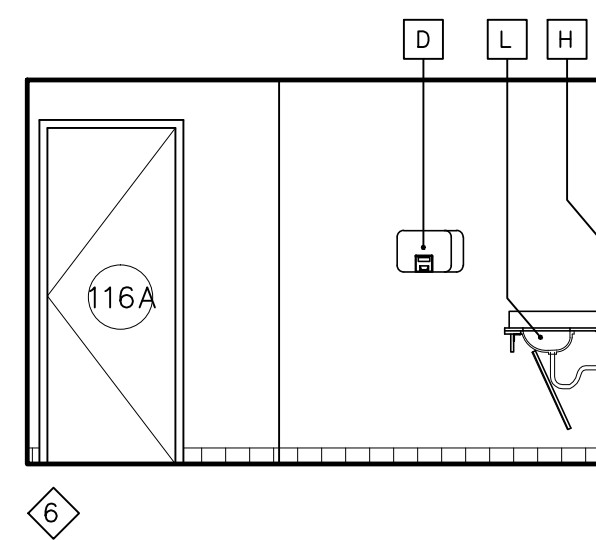

SCALE: 1/4" = 1'-0"

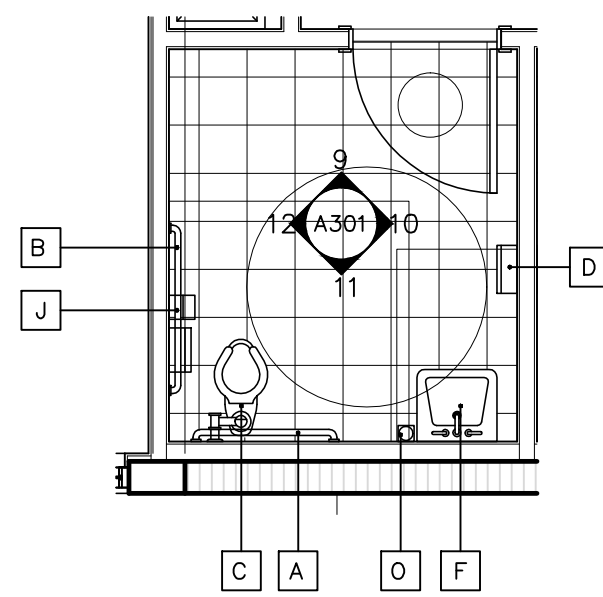

3  
A301  
**RESTROOM PLAN**  
SCALE: 1/4" = 1'-0"  
(SEE 'ID' DWGS. FOR RESTROOM FIXTURE & FINISHES SPECIFICATIONS)

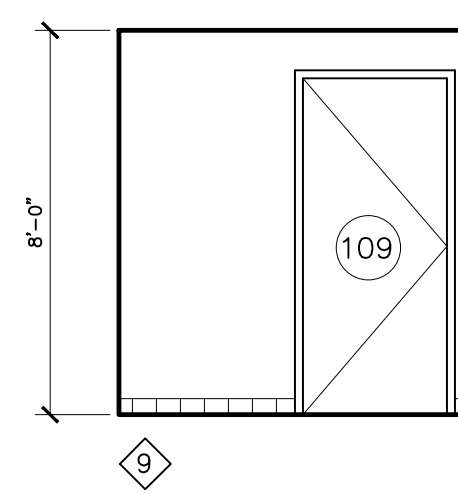

**ELEVATIONS**

(SEE 'ID' DWGS. FOR RESTROOM FIXTURE & FINISHES SPECIFICATIONS)

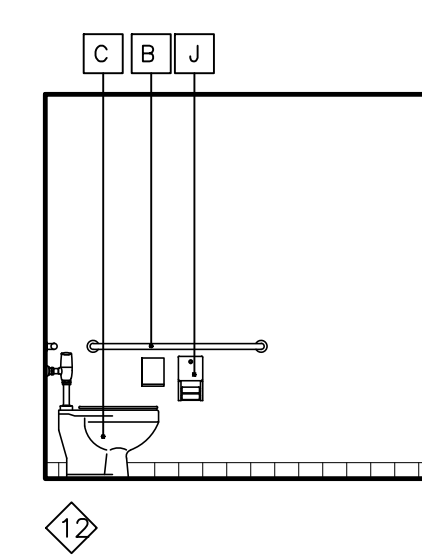
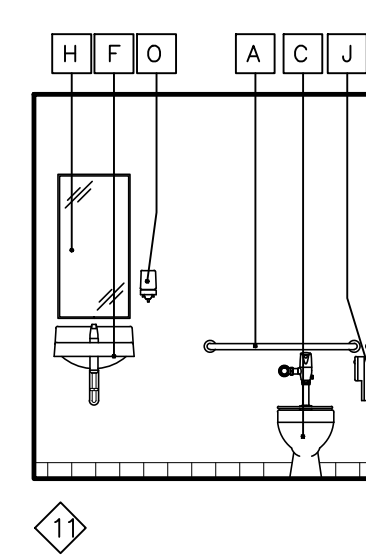
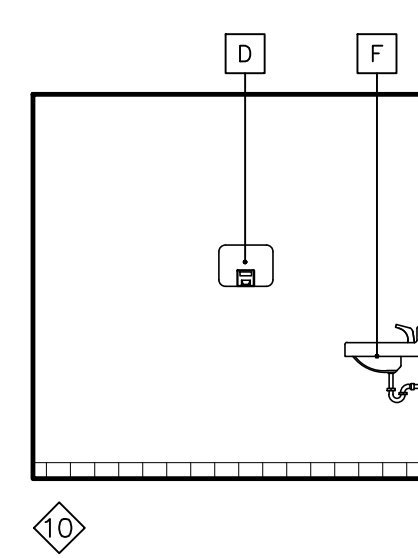

SCALE: 1/4" = 1'-0"

RESTROOM ACCESSORIES & FIXTURES SCHEDULE (SEE 'ID' DWGS. FOR ACCESSORY MODEL #'S.)				
MARK	DESCRIPTION	MODEL #	MOUNTING HT.	REMARKS
A	36" L GRAB BAR	-	33" TO C/L	-
B	42" L GRAB BAR	-	33" TO C/L	-
C	H.C. WATER-CLOSET, FLOOR-MOUNT, TANK TYPE	-	17" TO T.O. RIM	-
D	HAND DRYER, WALL-MOUNT, ELECTRIC	-	48" TO B.O. OUTPUT	-
E	URNINAL, WALL-MOUNT W/ AUTO FLUSH-VALVE	-	17" TO T.O. H.C. RIM	-
F	H.C. LAVATORY, WALL-MOUNT W/ MANUAL MIXING FAUCET	-	34" TO T.O. RIM	-
H	MIRROR, 18"W. X 36" H., WALL-MOUNT, W/ STN. STL. FRAME	-	40" TO B.O. FRAME	-
I	SOAP DISPENSER, WALL-MOUNT	-	48" TO B.O. OUTPUT	-
J	TOILET TISSUE DISPENSER, WALL-MOUNT, TWIN ROLL	-	17" TO B.O. OUTPUT	-
K	SANITARY NAPKIN DISPOSAL, WALL-MOUNT	-	28" TO T.O. UNIT	-
L	LAVATORY, UNDER-COUNTER MOUNT W/ MANUAL MIX FAUCET	-	UNDERSIDE OF COUNTER	-
M	TOILET PARTITION SYS., FLOOR TO CLG. MOUNT, PHENOLIC	-	-	-
N	SOLID SURFACE COUNTER & P. LAM. FASCIA ON PLYWD. ON WELDED STL. FRAME W/ DIAG. KICKERS ATT. TO WALL FRAMING	-	34" TO T.O. COUNTER	-
O	P. LAM. ON PLYWD. REMOVABLE VERT. SKIRT ATT. TO FRAME	-	-	-
P	MIRROR, VANITY WALL WIDTH, 36" H., WALL-MOUNT	-	40" TO B.O. MIRROR	-
Q	WARDROBE HOOK, BACK OF DOOR MOUNT	-	5'-0" A.F.F.	-
R	NOT USED	-	-	-

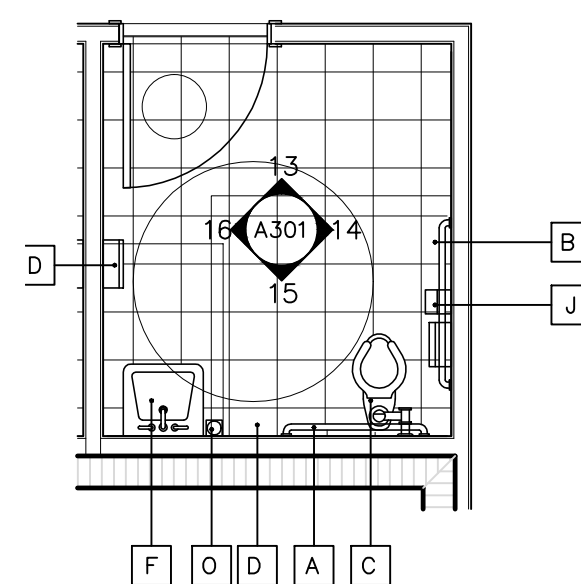

4  
A301  
**RESTROOM PLAN**  
SCALE: 1/4" = 1'-0"  
(SEE 'ID' DWGS. FOR RESTROOM FIXTURE & FINISHES SPECIFICATIONS)

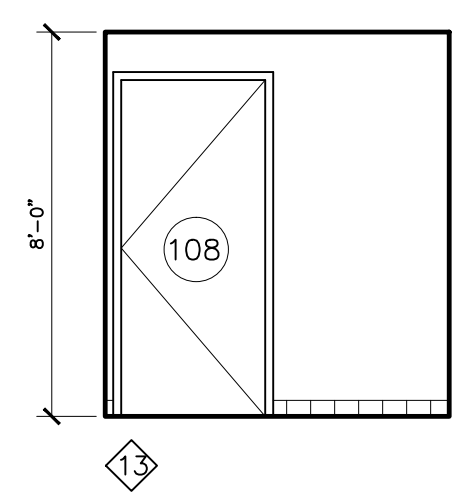

**ELEVATIONS**

(SEE 'ID' DWGS. FOR RESTROOM FIXTURE & FINISHES SPECIFICATIONS)

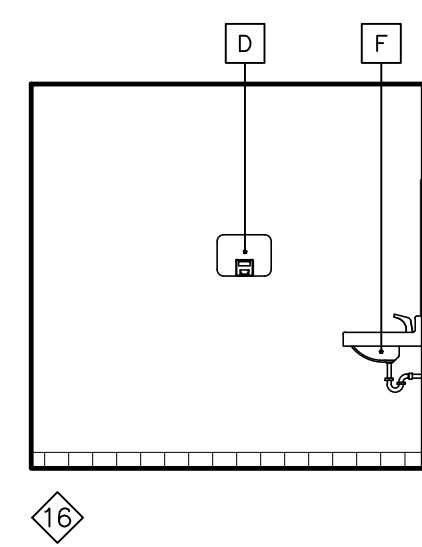
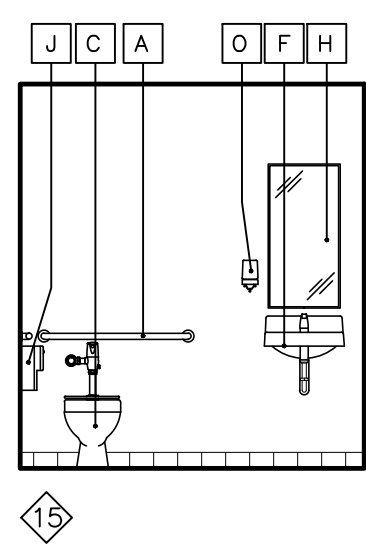
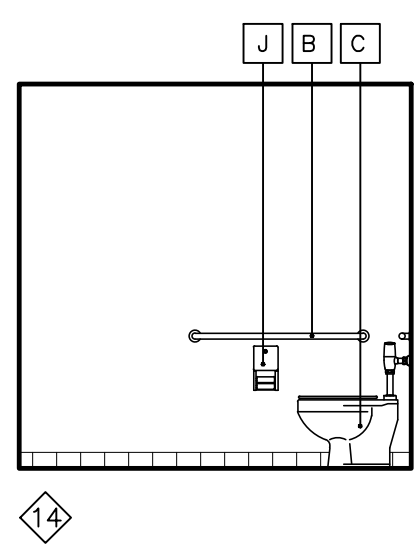

SCALE: 1/4" = 1'-0"

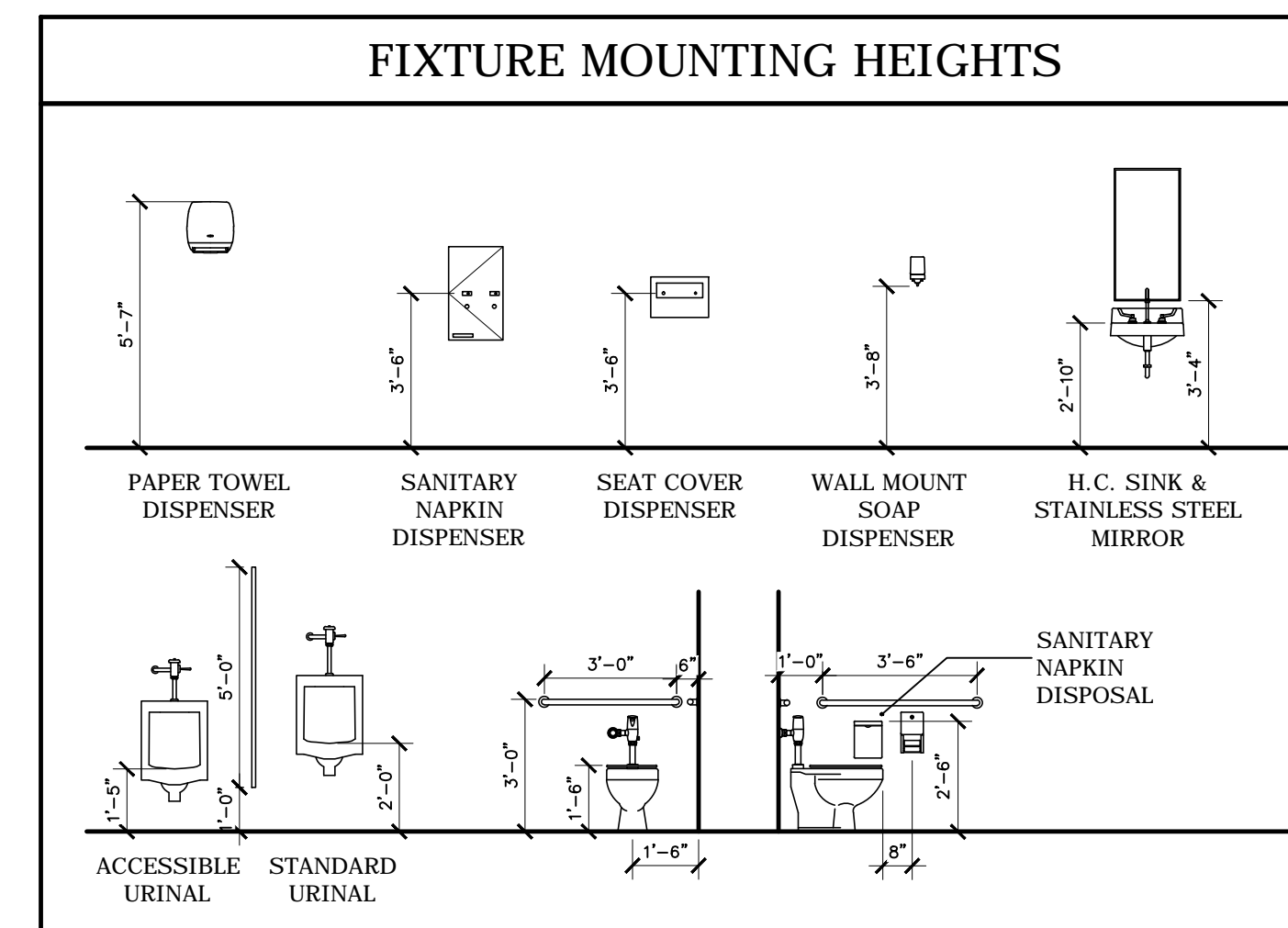

REVISIONS	BY

**Slattery & Associates**  
ARCHITECTS  
PLANNERS  
2060 NW BOCA RATON BLVD.  
SUITE 2  
BOCA RATON, FL 33431  
TEL: 561-392-3848  
FAX: 561-392-5402  
WWW.SLATTERYARCHITECTS.COM

**WOODFIELD HUNT CLUB  
CLUBHOUSE RENOVATION  
AND EXPANSION**  
4420 WOODFIELD BLVD.  
BOCA RATON, FLORIDA

SLATTERY & ASSOCIATES  
FLORIDA REGISTRATION # AA0003381  
DATE OF SEAL: 7-27-16

RESTROOM PLANS AND ELEVATIONS

DRAWN	CR, DR
CHECKED	CR
DATE	7-21-16
SCALE	AS NOTED
JOB NO.	2014-33
SHEET	A301

C.D. - 7-21-16