

MOVABLE PARTITION BASIS OF DESIGN:
 MANUFACTURER: MODERNFOLD
 SERIES: ACOUSTI-SEAL ENCORE
 MODEL: SINGLE PANEL

10 MOVABLE PARTITION SECTION
 SCALE: 3/4" = 1'-0"

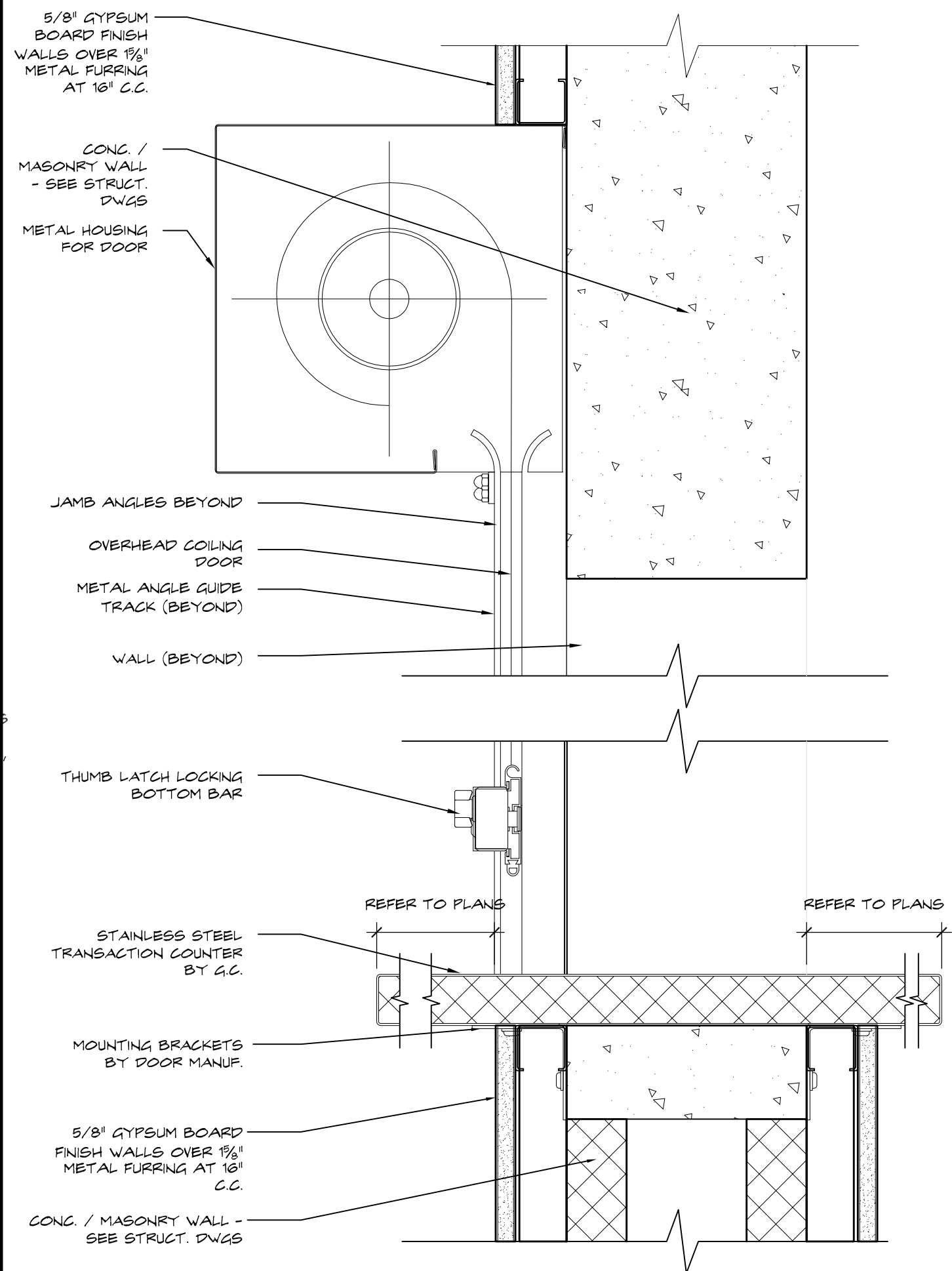

8 COILING COUNTER DOOR SECTION
 SCALE: 3/4" = 1'-0"

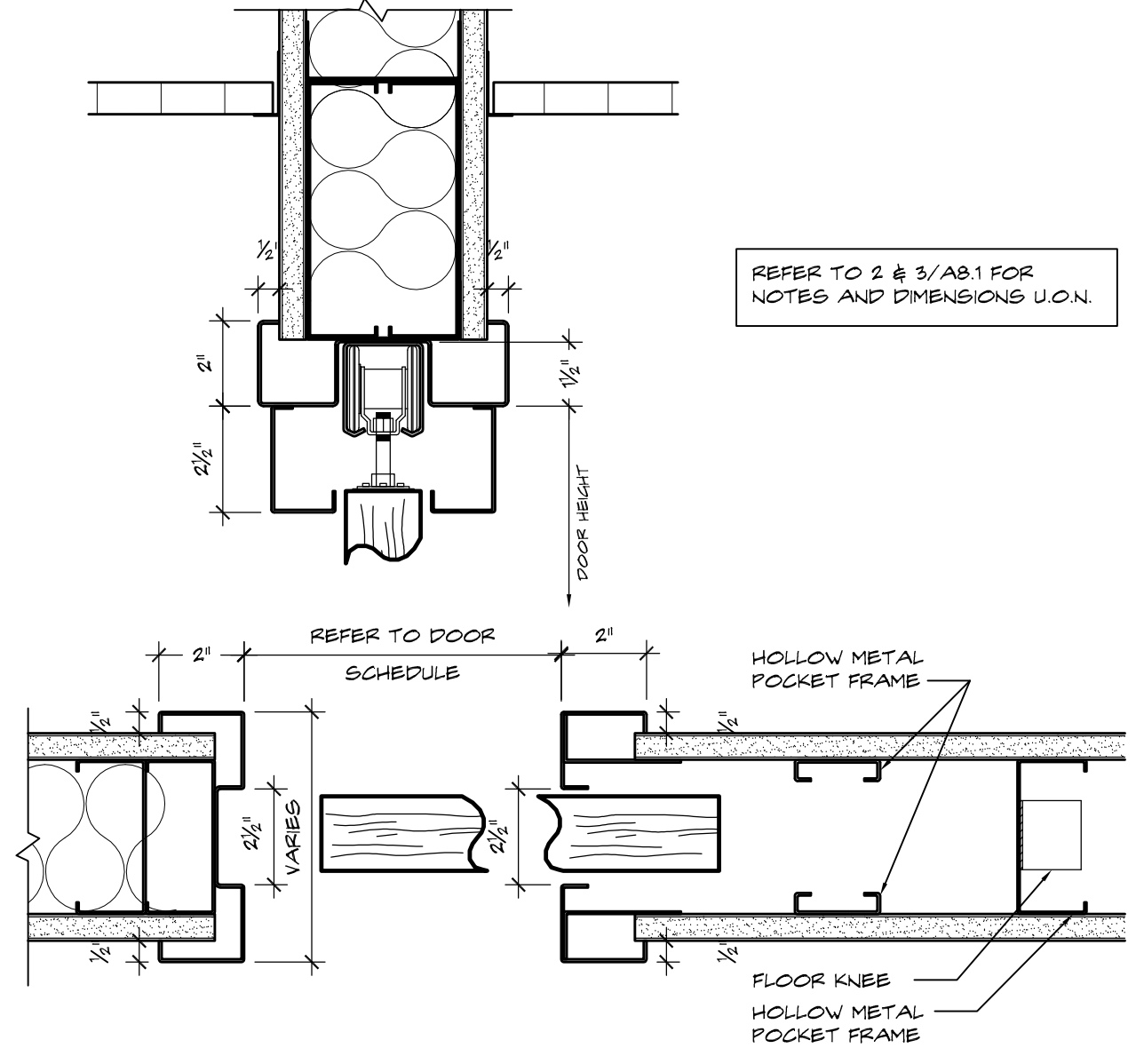

6 POCKET DOOR DETAILS
 SCALE: 3/4" = 1'-0"

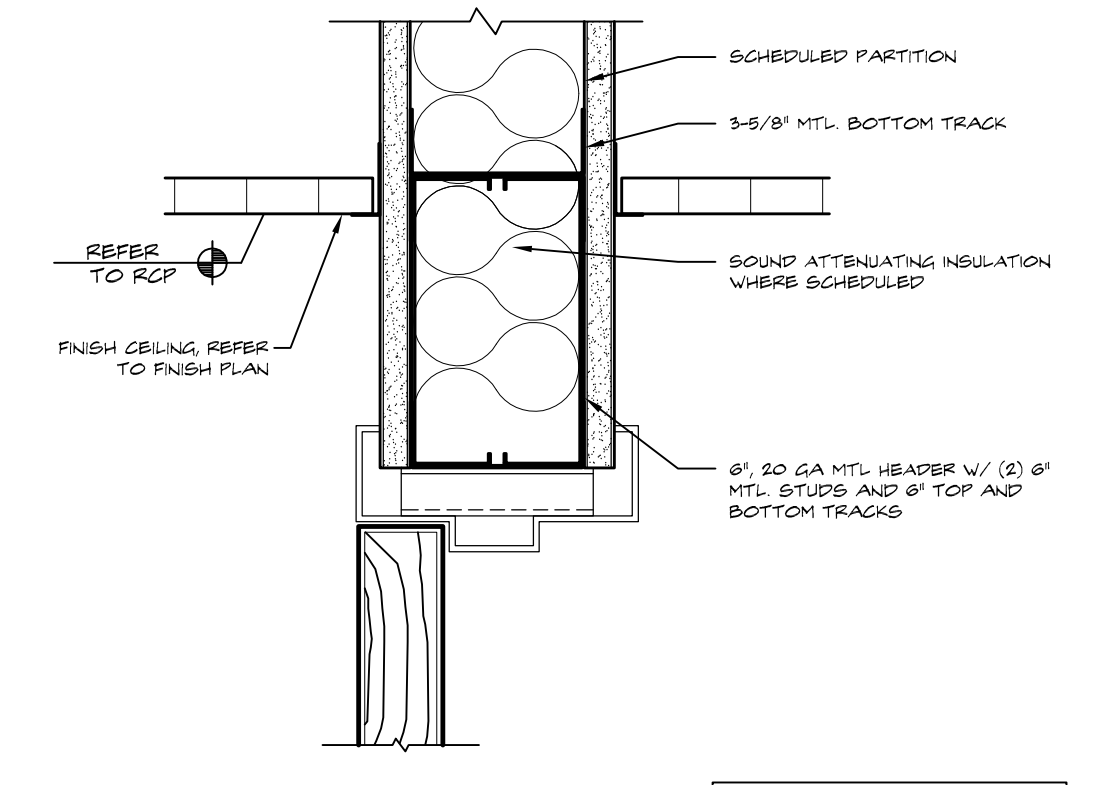

3 TYPICAL INTERIOR HEAD DETAIL
 SCALE: 3/4" = 1'-0"

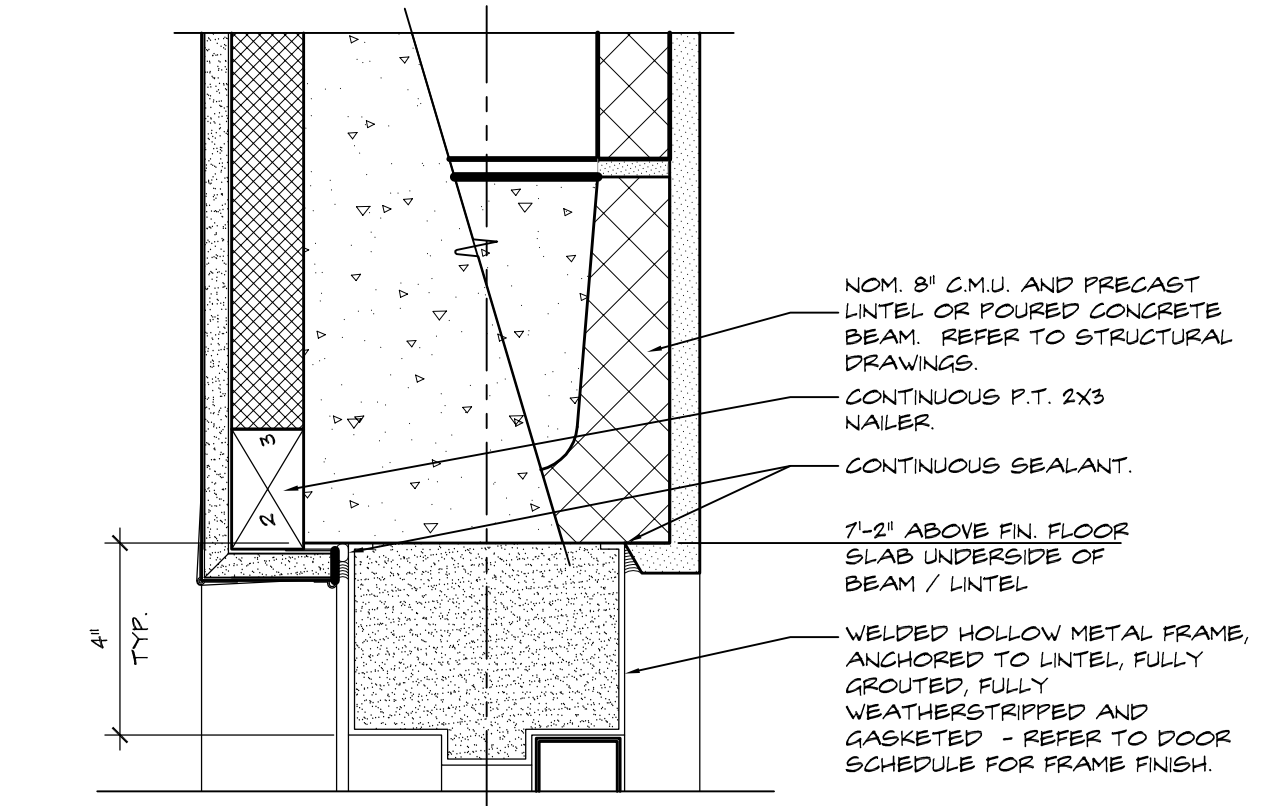

5 TYPICAL EXTERIOR HEAD DETAIL
 SCALE: 3/4" = 1'-0"

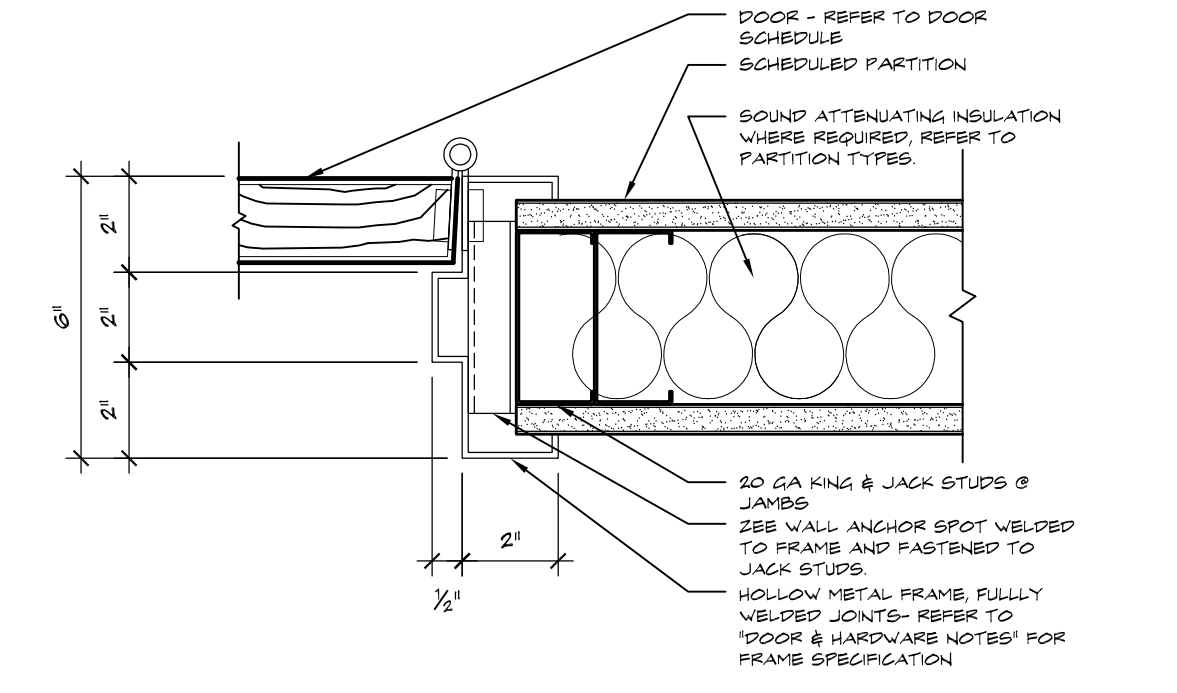

2 TYPICAL INTERIOR JAMB DETAIL
 SCALE: 3/4" = 1'-0"

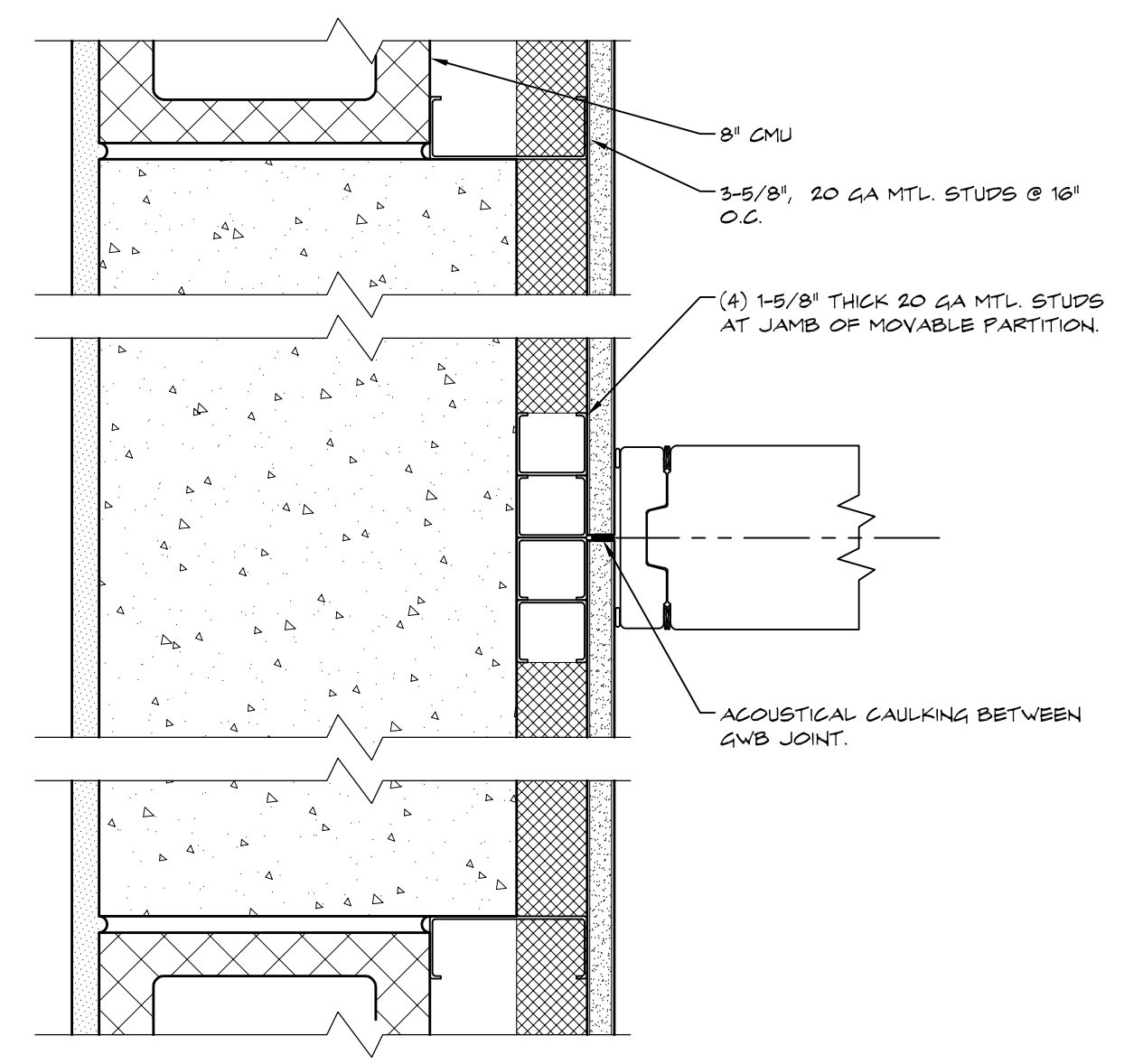

9 MOVABLE PARTITION JAMBS
 SCALE: 3/4" = 1'-0"

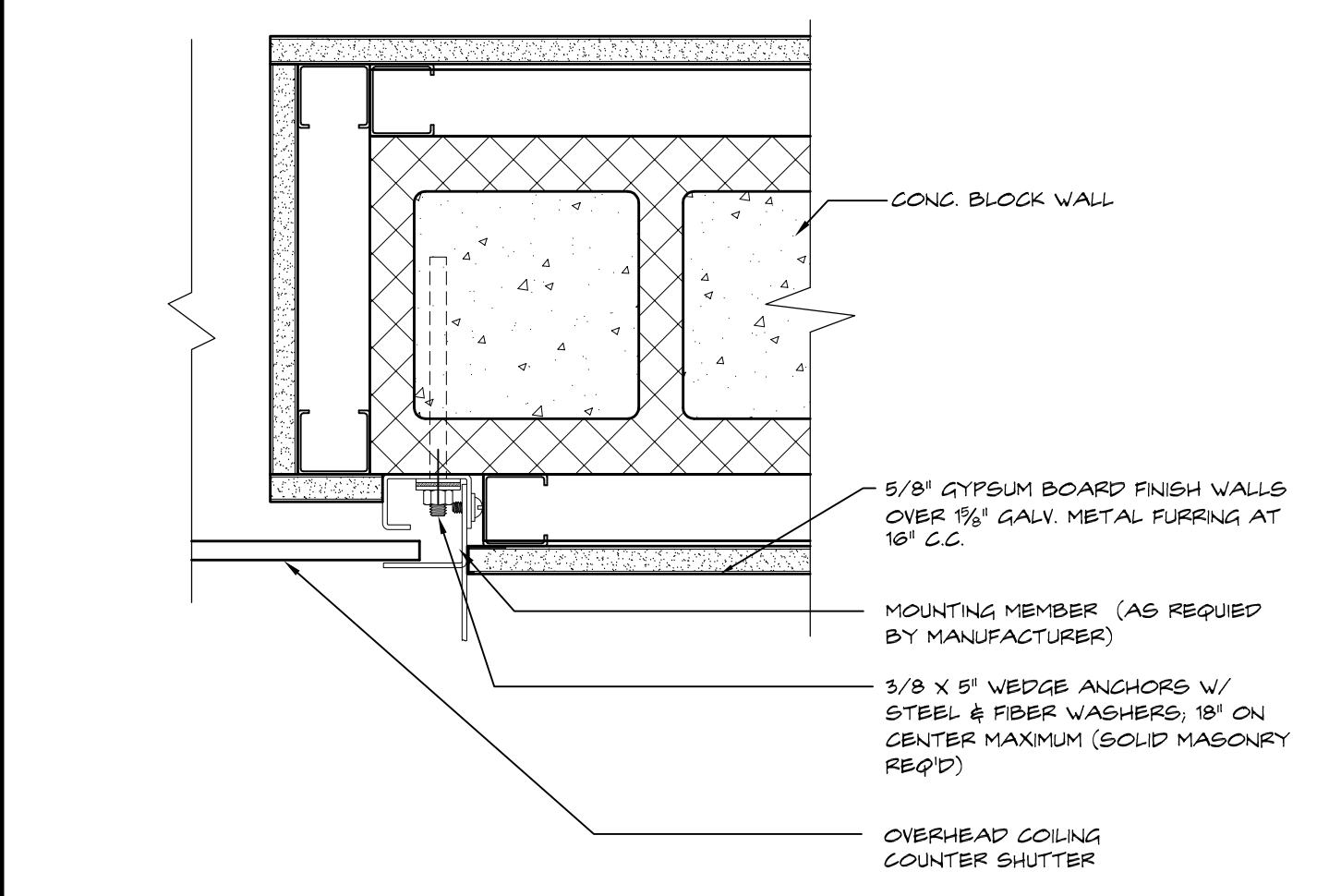

7 COILING COUNTER DOOR JAMB
 SCALE: 3/4" = 1'-0"

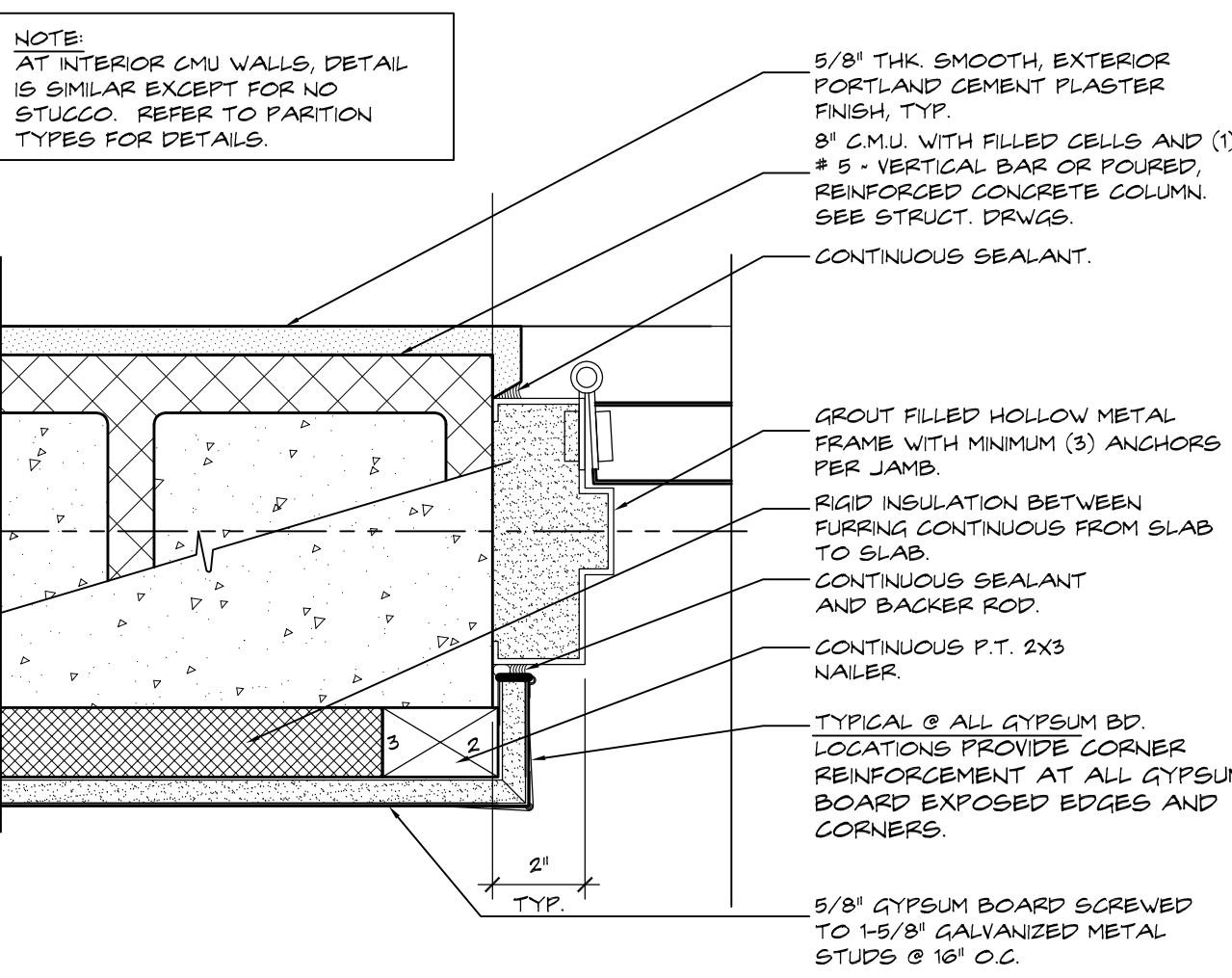

4 TYPICAL EXTERIOR JAMB DETAIL
 SCALE: 3/4" = 1'-0"

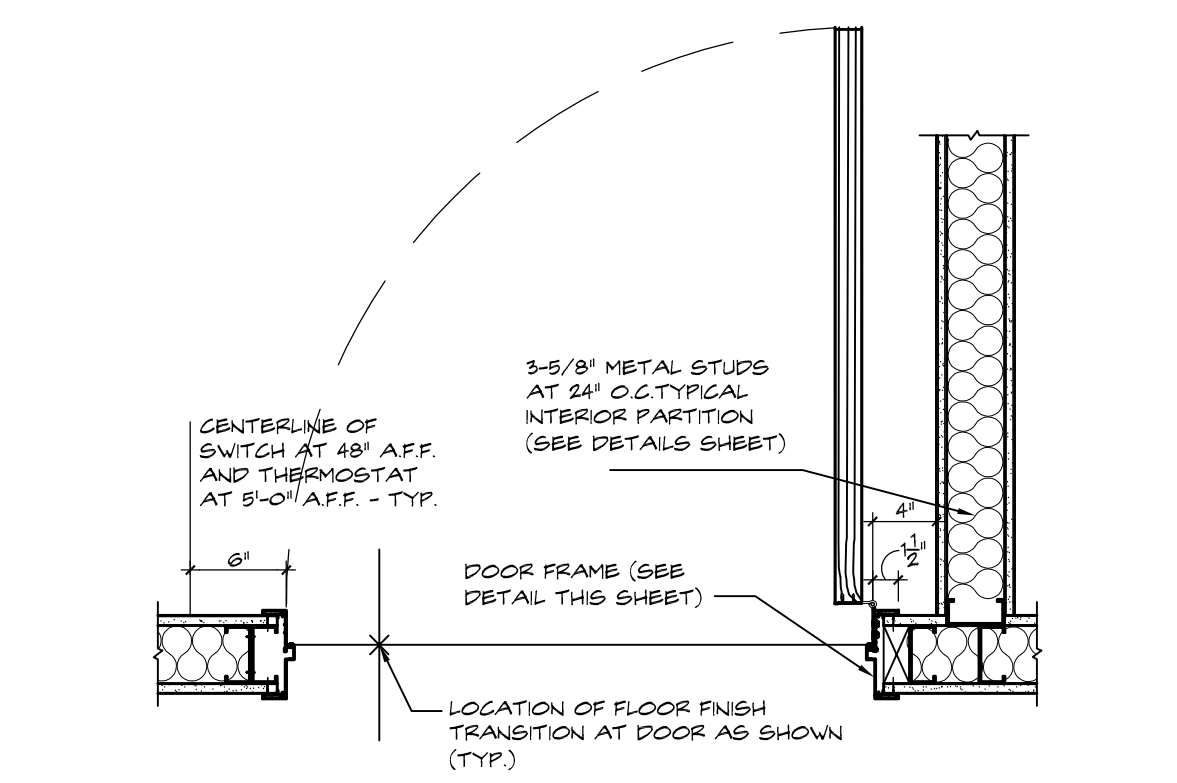

1 TYPICAL INTERIOR SWING DOOR LOCATION
 SCALE: 1/4" = 1'-0"

THESE DRAWINGS ARE FOR THE EXCLUSIVE USE OF GLIDDEN SPINA + PARTNERS, INC. AND MAY NOT BE REPRODUCED, REPRODUCED OR USED IN ANY MANNER WITHOUT THE EXPRESS WRITTEN CONSENT OF GLIDDEN SPINA + PARTNERS, INC. ALL RIGHTS RESERVED.

Revisions:	

Project no: 14224
 Date: 09.09.16
 Drawn by: WS
 Project Architect: WC / DR