

Song + Associates

Architecture • Planning • Interior Design

1545 Centrepark Drive North
West Palm Beach, Florida 33401

Telephone: 561-655-2423
Fax: 561-655-1482

AA - 0003165 IP - 0001095

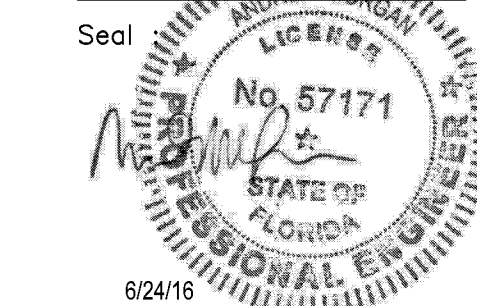

Name : Andrew Morgan
License # : PE57171

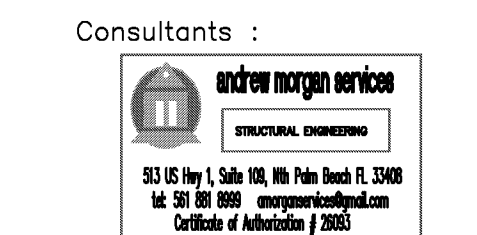

COPYRIGHT © 2015 SONG & ASSOCIATES, INC. ALL RIGHTS RESERVED. These drawings and specifications are instruments of service and shall remain the property of Song & Associates, Inc. whether the project for which they were prepared is executed or not. They are not to be used in any manner on other projects or extensions to this project except by agreement in writing with the appropriate commission to Song & Associates, Inc. Reproduction of drawings or specifications without the written consent of Song & Associates, Inc. is prohibited.

SWA-PBC MAINTENANCE FACILITY LOCKER ROOM



6527 N. Jog Road
West Palm Beach, FL 33412

Key Plan:

Revisions:

1 04/15/16

Date: 07/14/2016

S+A Project No.: 16003

Owner Project No.:

Drawn By: LE

Checked By: RC

Phase:

BID SET

Sheet Title:

FLOOR SLAB PLAN

Sheet #:

S002

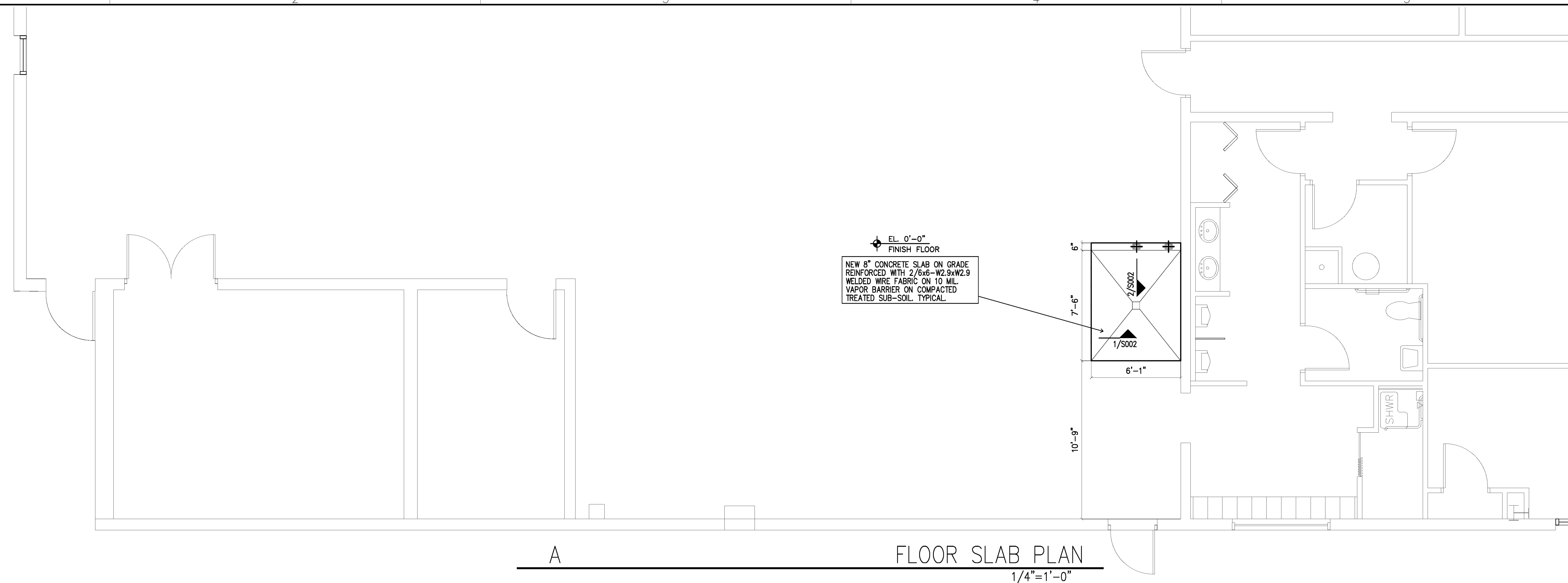

A FLOOR SLAB PLAN
1/4"=1'-0"

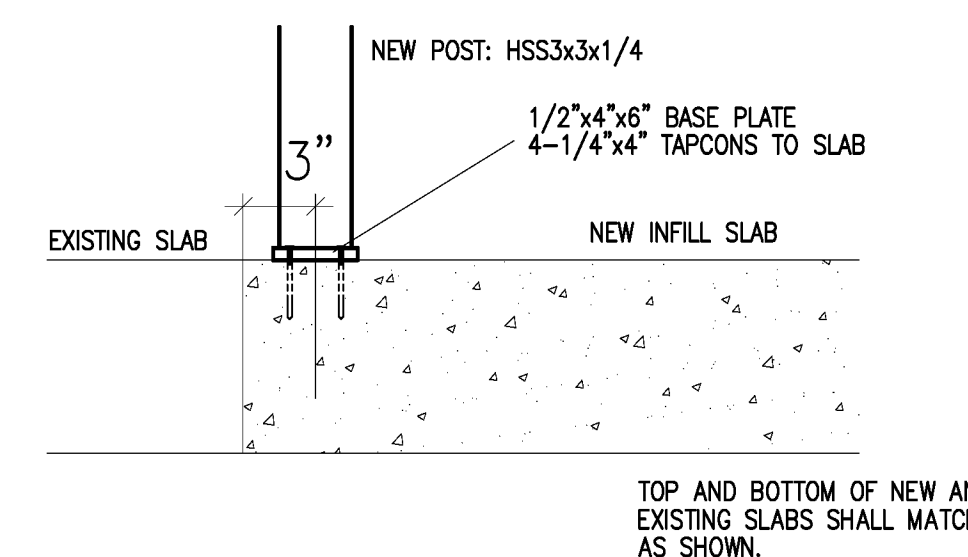

2 NEW POST DETAIL
1 1/2"=1'-0"

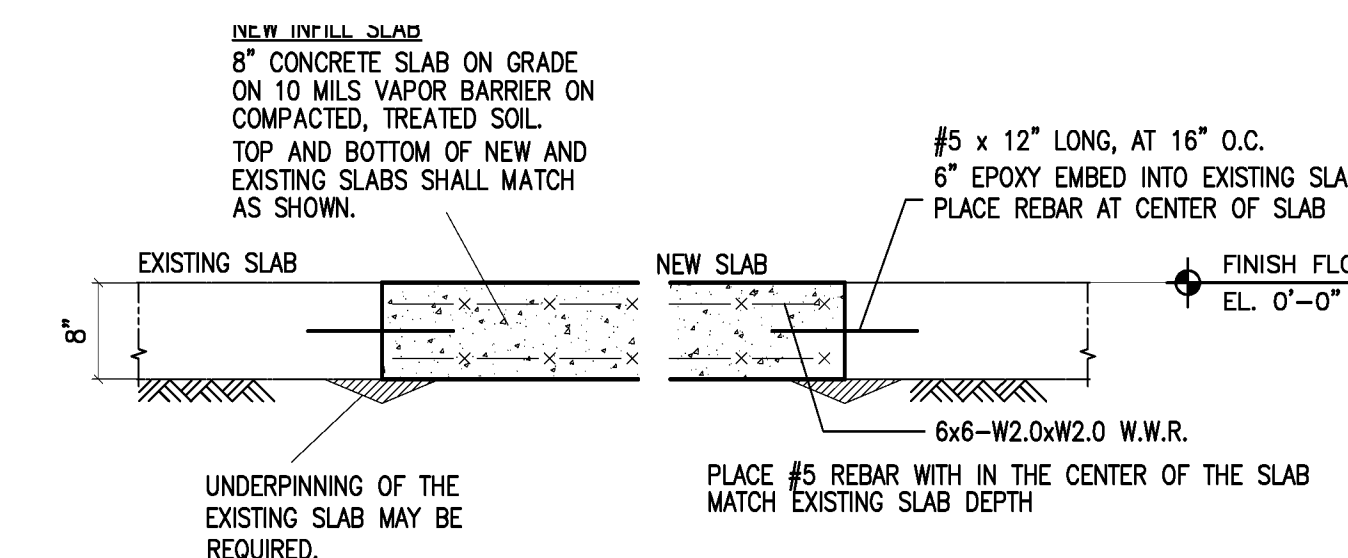

1 NEW SLAB AT EXISTING SLAB DETAIL
3/4"=1'-0"

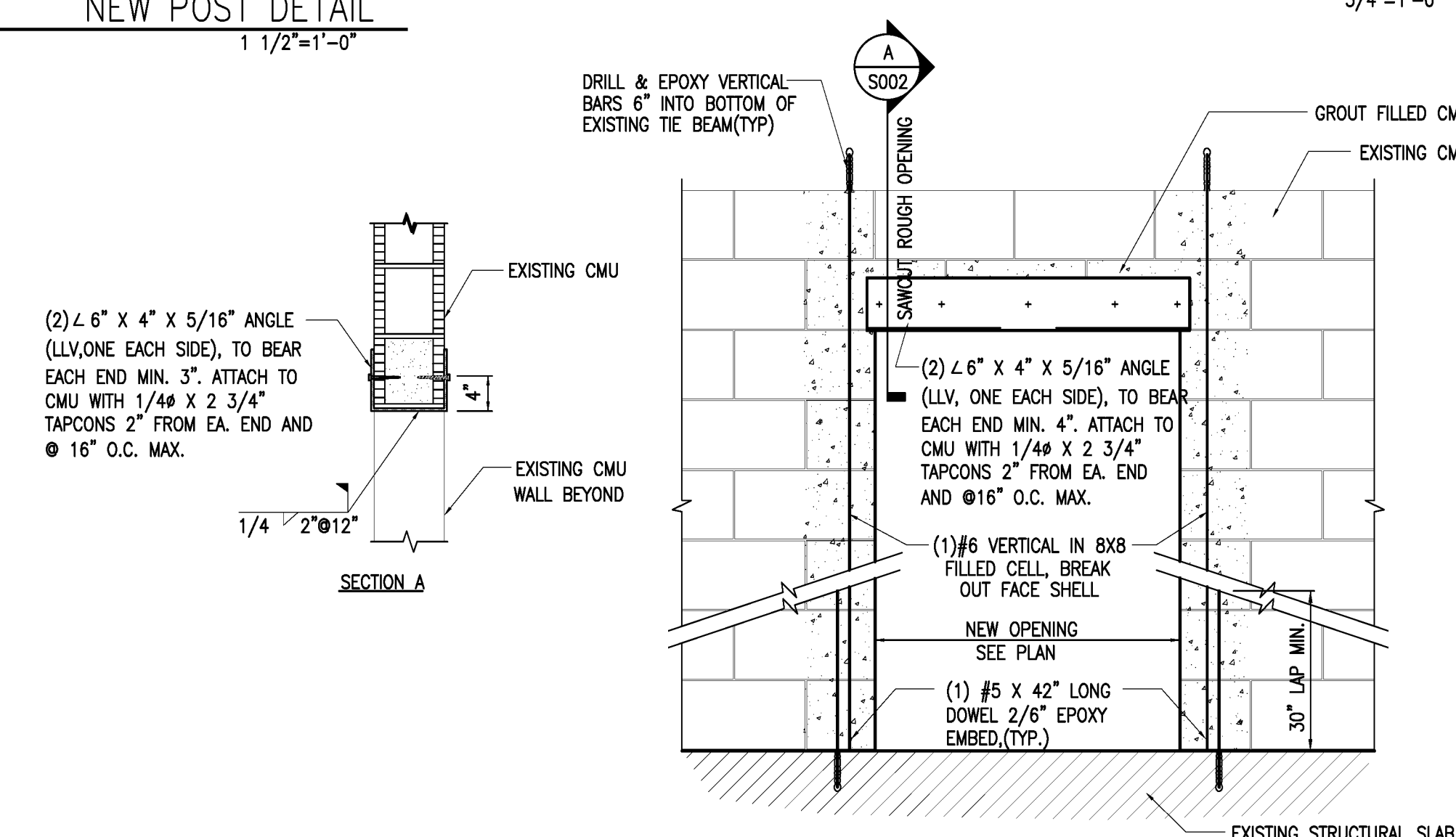

3 NEW OPENING IN WALL DETAIL
3/4"=1'-0"