

TYPICAL MASONRY FILLED CELL DETAIL
N.T.S.

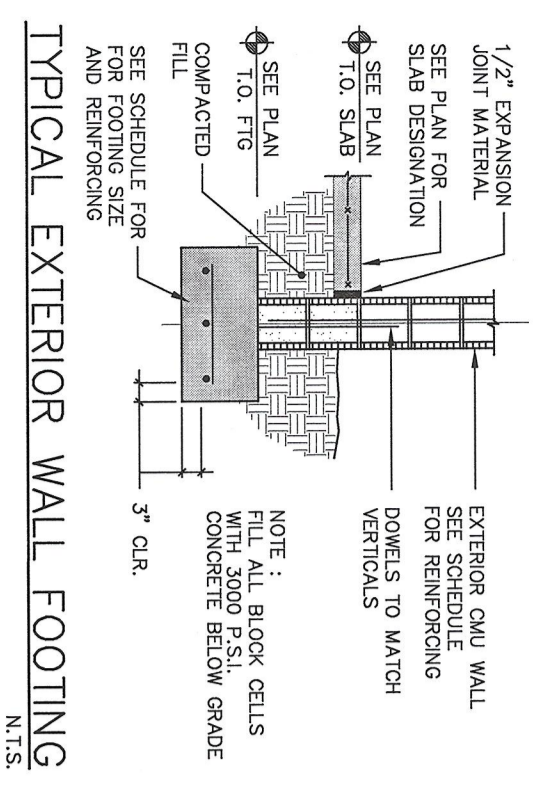

TYPICAL EXTERIOR WALL FOOTING
N.T.S.

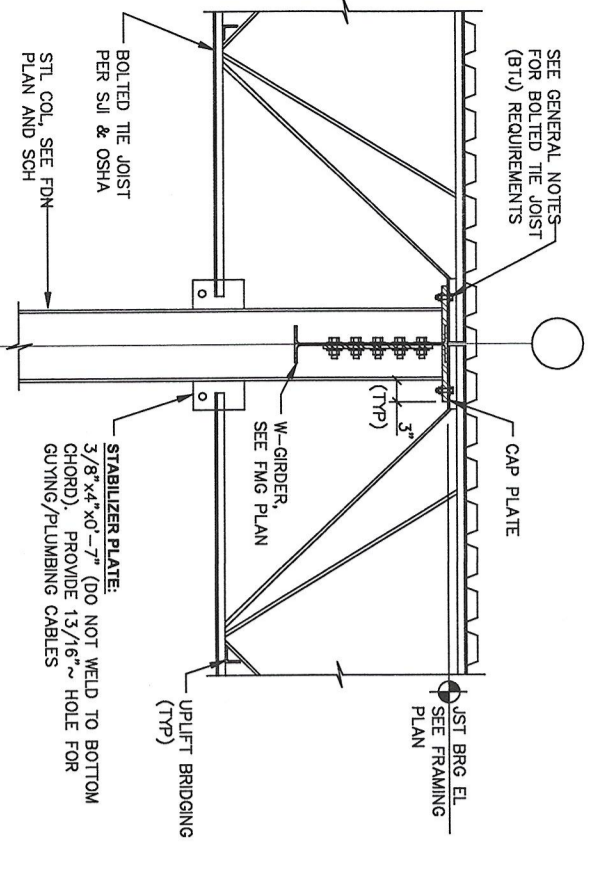

TYPICAL DETAIL @ BOLTED JOIST
(B.T.U.) & SILL COLUMN.
N.T.S.

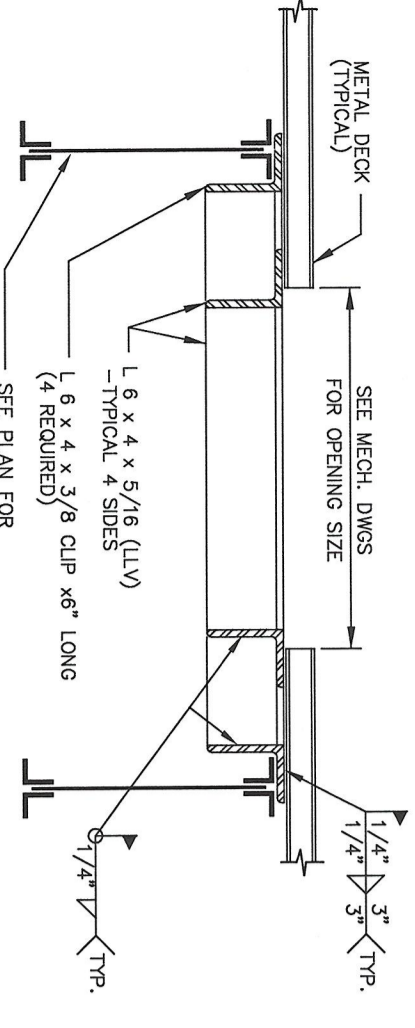

TYPICAL ROOF OPENING DETAIL
N.T.S.

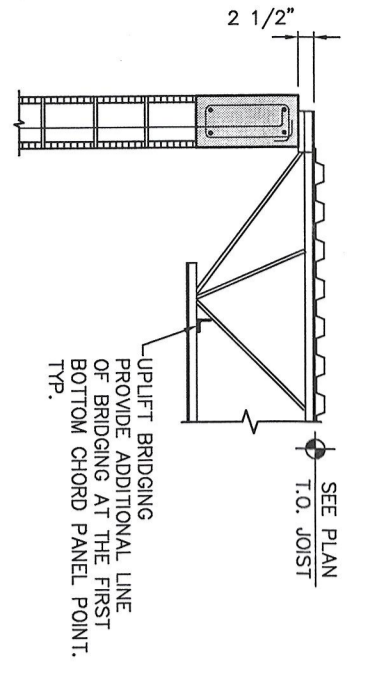

UPLIFT BRIDGING AT BOTTOM CHORD
N.T.S.

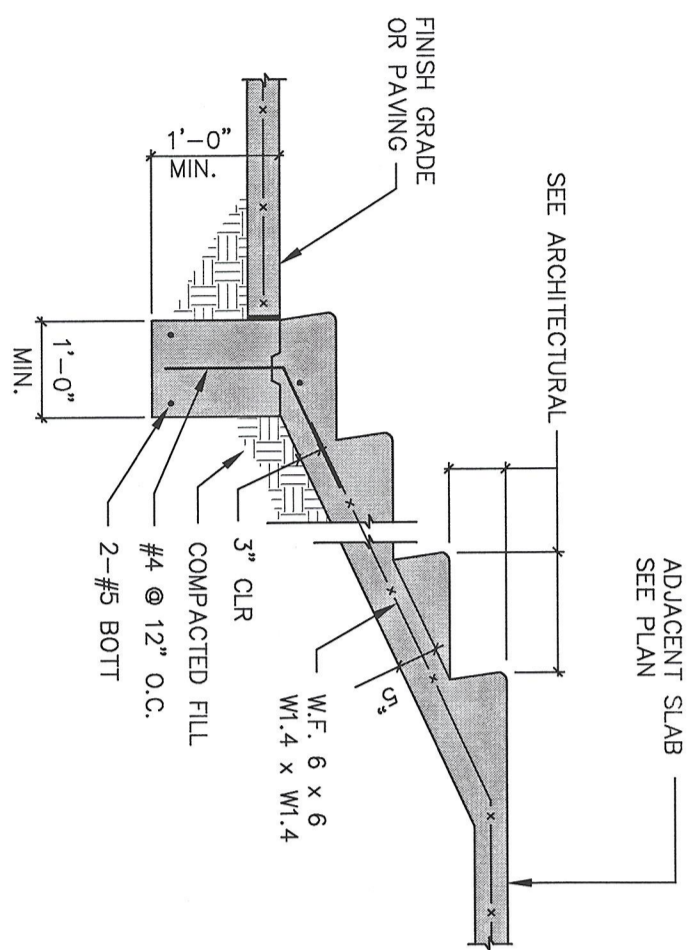

TYPICAL CONCRETE STAIR
ON GRADE
N.T.S.

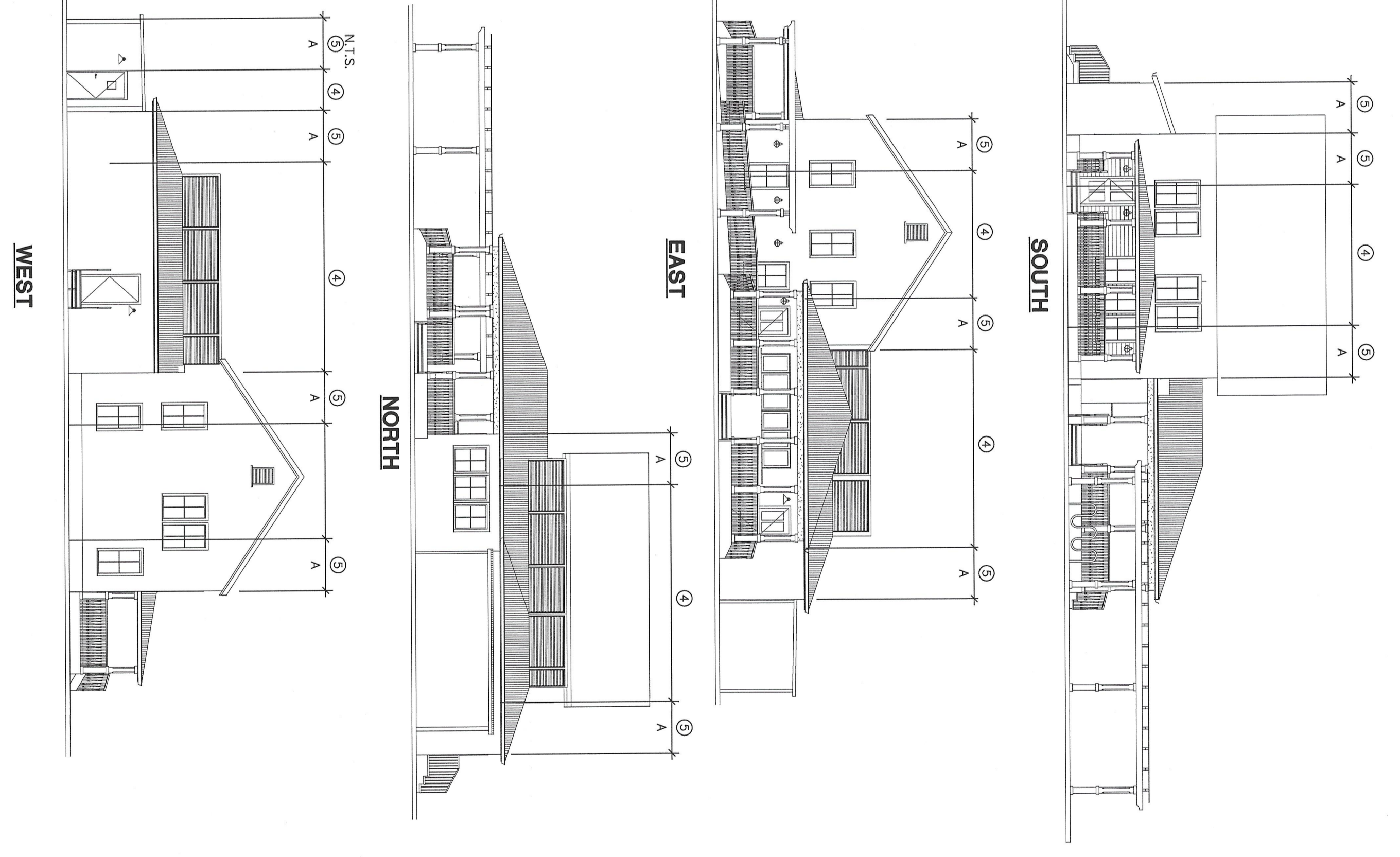

WIND DESIGN WALL PRESSURE ELEVATIONS
N.T.S.

ALLOWABLE

COMPONENT & CLADDING WIND DESIGN PRESSURES		WALL WIND LOADS (SEE NOTE 3)	
PRESSURES* BASED ON V _w	ROOF WIND LOADS (10 SF)	WALL WIND LOADS (10 SF)	
Kd IS INCLUDED	1 23.17	2 23.17	3 23.17
Kd IS INCLUDED	4 41.35	5 41.35	
PRESSURE (PSF)	-43.42	-22.86	-22.86
SUCTION (PSF)	-44.86	-55.37	

1. EXTERIOR CORNER SPANNING IN RELEVANT WALL SPAN; WITH FLIGHT BUILDING CORNER ENJOINT (CP4) IF APPLICABLE.
2. REFER TO STRUCTURAL NOTES FOR ALL WIND LOAD PARAMETERS.
3. CORNER DISTANCE, A = 6'-0" FEET

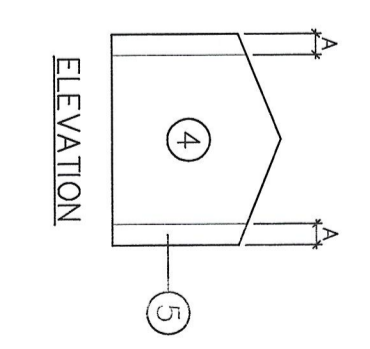

PERMIT SET
11/23/16

ONNME
O'Donnell, Naccarato, Mignogna
STRUCTURAL ENGINEERS
Jackson
211 E OCEAN AVENUE, SUITE 1114
BOYNTON BEACH, FLORIDA 33435
(813) 353-7774 FAX (813) 353-5353
LIC. #00040936 JOB # 772.092

